

## Eleon

Ventilation and emergency  
escape roof hatch

Workshop manual

## 1 Introduction

1.1	Content and purpose	101
1.2	Effectivity of the workshop manual	101
1.3	Meaning of highlighted content	101
1.4	Symbols	101
1.5	Further documentation to be used	101
1.6	Safety information and regulations	101
1.6.1	General safety regulations	101
1.7	Suggestions for improvement and change	102

## 2 Technical Data

## 3 Description of assemblies and components

3.1	The frame	301
3.2	The lifting mechanisms	301
3.3	Control unit	304
3.4	Hatch cover	304
3.5	Interior trim	304

## 4 Hatch functions

4.1	Eleon and Eleon Clear	401
4.2	Eleon Comfort and Clear Comfort	401
4.2.1	Control unit	401
4.2.2	Control principle	401
4.2.3	Operating indicator	402
4.2.4	Control sequence	403

## 5 Troubleshooting

5.1	General	501
5.2	General error symptoms	501
5.3	Functional check of the hatch	503
5.3.1	Roof hatch - operated manually	503
5.3.2	Roof hatch - operated electrically	503
5.4	Visual inspection of a lifting mechanism	503
5.4.1	Lifting mechanism - operated manually	503
5.4.2	Lifting mechanism - operated electrically	503
5.5	Checking the motor of a lifting mechanism	503
5.6	Manual adjustment of the electrically operated lifting mechanism	503

## 6 Wiring diagrams

6.1	General	601
-----	---------	-----

## 7 Servicing

7.1	General	701
7.2	Cleaning of the roof hatches	701

## 8 Components removal and installation

8.1	General	801
8.2	Seal removal and installation	804

8.3	Cover assembly removal and installation (glass cover)	804
8.4	Cover assembly removal and installation (plastic cover)	805
8.5	Lifting mechanism removal and installation	805
8.6	Control unit removal and installation	806
8.7	Wiring harness removal and installation	807
8.8	Emergency hammer removal and installation	807
<b>9</b>	<b>Modifications and retrofits</b>	
<b>10</b>	<b>Packing/storage/shipping</b>	
10.1	General	1001

# 1 Introduction

## 1.1 Content and purpose

This workshop manual is used during service and repair of ventilation and emergency escape hatches (further referred to as roof hatches) Eleon, Eleon Comfort, Eleon Clear and Eleon Clear Comfort.

## 1.2 Effectivity of the workshop manual

The workshop manual applies to roof hatches listed on the title page of this document. It may be subjected to modifications and amendments. The respectively currently effective version is binding. This version can be found in the download center on [www.spheros.com](http://www.spheros.com).

## 1.3 Meaning of highlighted content

Throughout this manual the emphasized words Warning!, Caution!, ATTENTION: and NOTE: used as follows:

 <b>Warning!</b>	<b>Danger to life and health!</b>
---	-----------------------------------

This caption is used to indicate possible severe injuries or fatal accidents if instructions or procedures are carried out incorrectly or entirely disregarded.

 <b>Caution!</b>	<b>Hazardous to health!</b>
---	-----------------------------

This caption is used to indicate possible minor injuries if instructions or procedures are carried out incorrectly or entirely disregarded.

**ATTENTION:**

This caption points to actions which may cause material damage.

**NOTE:**

This caption is used to draw attention to an important feature.

## 1.4 Symbols



Symbol tightening torque value: Identifies in graphics parts (eg nuts, bolts) that are to be mounted with a specific tightening torque. The torque values are shown at the symbol and are binding.

## 1.5 Further documentation to be used

The use of additional service literature is required. References are provided in the workshop manual at appropriate locations.

Use the following documents during operation and service of the roof hatches:

- Operating instructions
- Installation instructions
- Technical information (TI)
- Spare parts list

## 1.6 Safety information and regulations

Basically, general accident prevention provisions and the valid industrial safety directions must be adhered to. "General Safety Regulations" which exceed the framework of these provisions are listed below. The specific safety regulations which affect the present manual are issued highlighted in the individual sections or procedures.

### 1.6.1 General safety regulations

 <b>Warning!</b>	<b>Danger to life and health!</b>
---	-----------------------------------

When working on the bus roof or on any hoisting equipment, scaffolding etc. suitable safety precautions must be taken to prevent falls.

 <b>Caution!</b>	<b>Hazardous to health!</b>
---	-----------------------------

Read the Eleon Series Operating instructions before operating the roof hatch for first time. Familiarize yourself with the Eleon Series Installation instructions before you make any modifications to the existing roof hatch installation.

**NOTE:**

The Eleon Operating Instructions contain safety

instructions and regulations to be followed for safe operation of the roof hatch.

The Eleon Installation instructions contain the statutory regulations and other safety hints and regulations for the proper installation of the roof hatch(es).

## **1.7 Suggestions for improvement and change**

Please direct any complaints, improvement or modification suggestions regarding this manual to:

**[service@spheros.com](mailto:service@spheros.com)**

## 2 Technical Data

The following table contains the technical data of the individual versions of the Eleon series.

Table 201 Technical data

	Eleon	Eleon Comfort	Eleon Clear	Eleon Clear Comfort
Hatch cover dimensions (mm)	(A) 1092 x (B) 777	(A) 1092 x (B) 777	(A) 1055 x (B) 715	(A) 1055 x (B) 715
Hatch, interior opening (mm)	(C) 806 x (D) 602	(C) 806 x (D) 602	(C) 806 x (D) 602	(C) 806 x (D) 602
Height, close / open (mm)	(E) 68 / (F) 144	(E) 68 / (F) 144	(E) 29 / (F) 98	(E) 29 / (F) 98
Vent gap (mm)	(G) 68	(G) 68	(G) 59	(G) 59
Weight (kg)	11.5	12.5	11.0	11.5
Operating voltage (V)	--	12 / 24	--	12 / 24
Quiescent current	--	< 1mA	--	< 1mA
Glass	--	--	4mm, LT ca. 16%	4mm, LT ca. 16%
Fuse (A)	--	5 -> up to 2 hatches 10 -> 3 to 4 hatches	--	5 -> up to 2 hatches 10 -> 3 to 4 hatches
Emergency exit approval acc. to	UN ECE R.107 Rev. 6	UN ECE R.107 Rev. 6	UN ECE R.107 Rev. 6	UN ECE R.107 Rev. 6
Fire resistance approval acc. to	UN ECE R.118.02	UN ECE R.118.02	UN ECE R.118.02	UN ECE R.118.02
EMC approval acc. to		UN ECE R.10.05		UN ECE R.10.05

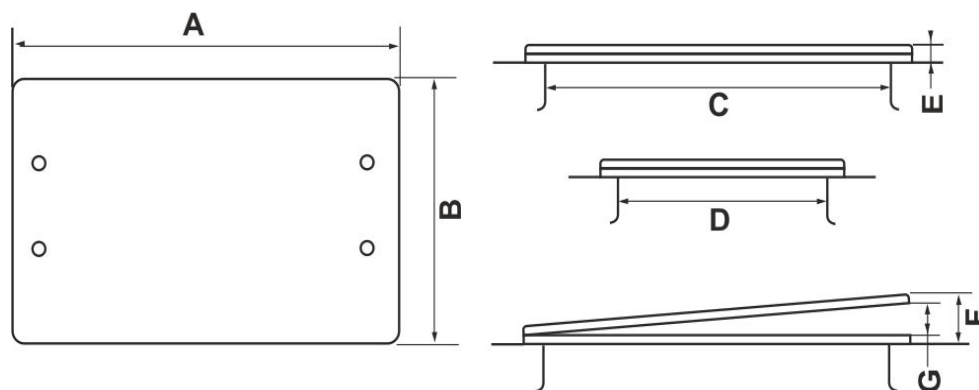

### 3 Description of assemblies and components

The roof hatches of the Eleon series are used for ventilation of the interior in city buses, coaches and intercity buses as well as for the emergency exit of persons in case of danger.

The roof hatches essentially consist of

- the frame
- the lifting mechanisms
- the control unit (electrical operated hatches only)
- the cover, and
- the interior trim.

For arrangement of the individual components, see Fig. 303 and Fig. 304.

#### 3.1 The frame

The frame consists of the 4 corner parts, which are connected by 2 short and 2 long profiles (see Fig. 303). The frame is the main structural element of each roof hatch. By means of it the roof hatch is attached to the bus structure. The frame accommodates the lifting mechanisms, the roof hatch seal and, in the case of the electrical versions, the control unit and the wiring harness.

#### 3.2 The lifting mechanisms

The 4 lifting mechanisms of each roof hatch make possible to open it at the front, at the rear, and both - at the front and rear. Each mechanism is connected by means of a cover carrier with the hatch cover.

##### *Manually operated lifting mechanism (Fig. 301)*

When opening and closing the hatch, tension or pressure is exerted on the cover carrier of the lifting mechanism via the handle on the hatch cover. This causes a folding or unfolding of a lever assembly.

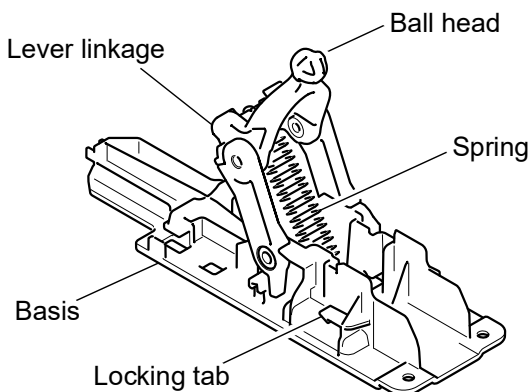

Fig. 301 Lifting mechanism - manually operated

A special tension spring ensures that the mechanism is pulled into the nearer of the two end positions. This creates the necessary closing or opening force.

##### *Electrically operated lifting mechanism (Fig. 302)*

Each of the lifting mechanisms raises or lowers a cover carrier, while the in direction of travel front and / or rear lifting mechanisms work synchronously.

The cover carriers are attached to the hatch cover.

In principle, an electric motor generates a linear movement via a spindle. This is converted via levers in a lifting or lowering movement of the cover carrier.

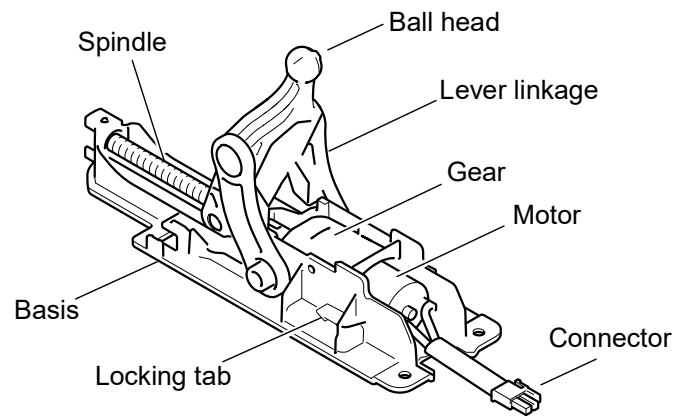
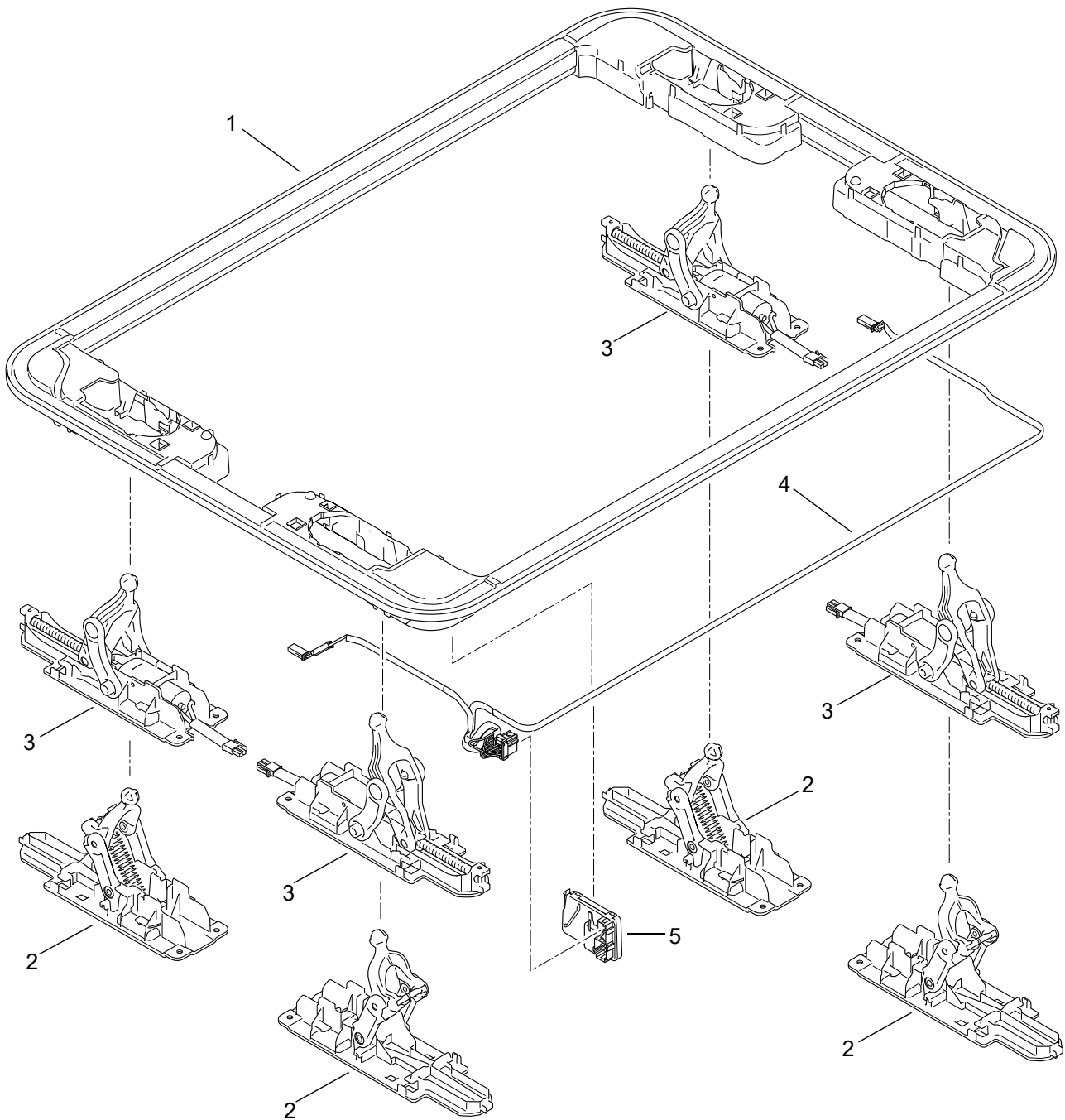

Fig. 302 Lifting mechanism - electrically operated



Hatch with plastic/glass cover - manually operated:

- 1 Frame
- 2 Lifting mechanism, manually operated

Hatch with plastic/glass cover - electrically operated:

- 1 Frame
- 3 Lifting mechanism, electrically operated
- 4 Wiring harness
- 5 Control unit

Fig. 303 Eleon hatches - components (part 1)



Hatch with plastic cover:

- 1 Seal
- 2 Cover carrier, upper part (4)
- 3 Cover carrier, lower part (4)
- 4 Retaining clip (4)
- 5 Screw (8)
- 6 Cover body
- 7 Emergency handle, outer
- 8 Gasket ring
- 9 Emerg. handle, inner
- 10 Screw
- 11 Covering

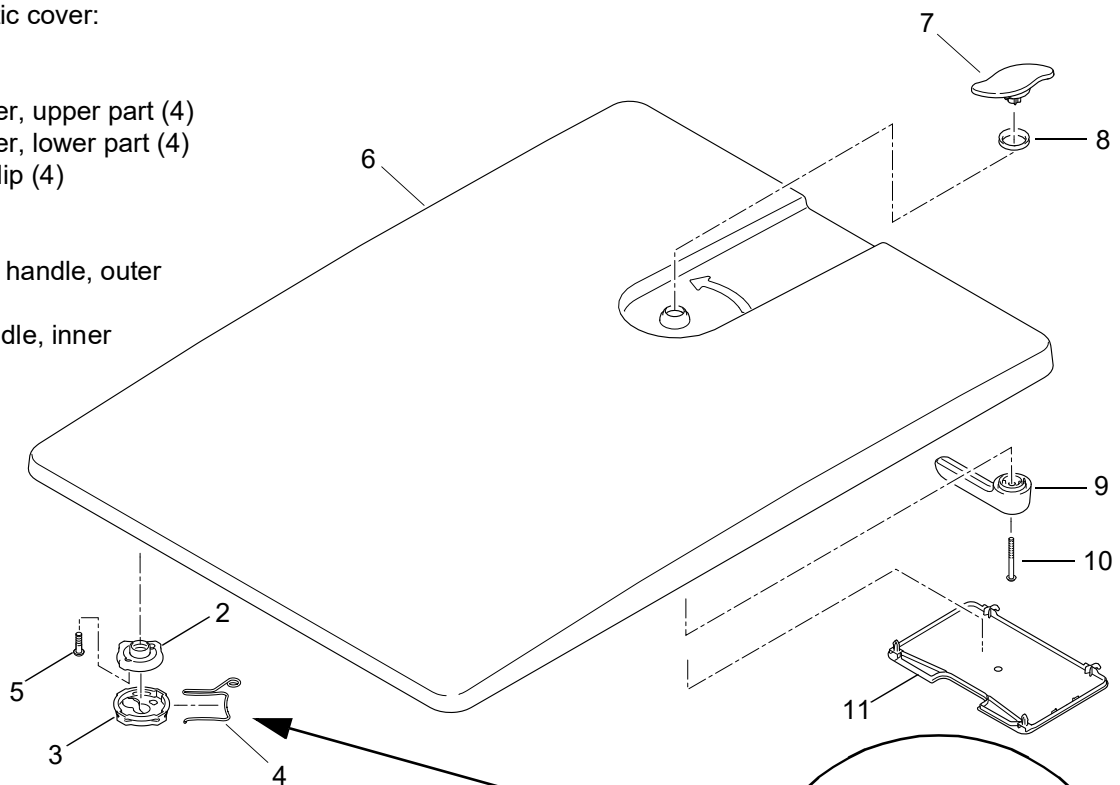

Hatch with glass cover:

- 1 Seal
- 2 Cover carrier, upper part (4)
- 3 Cover carrier, upper part (4)
- 4 Retaining clip (4)
- 12 Glass
- 13 Edge rubber
- 14 Screw, plastic (4)
- 15 Gasket ring
- 16 Gasket ring
- 17 Handle (2)
- 18 Gasket, handle (4)
- 19 Screw, handle (4)

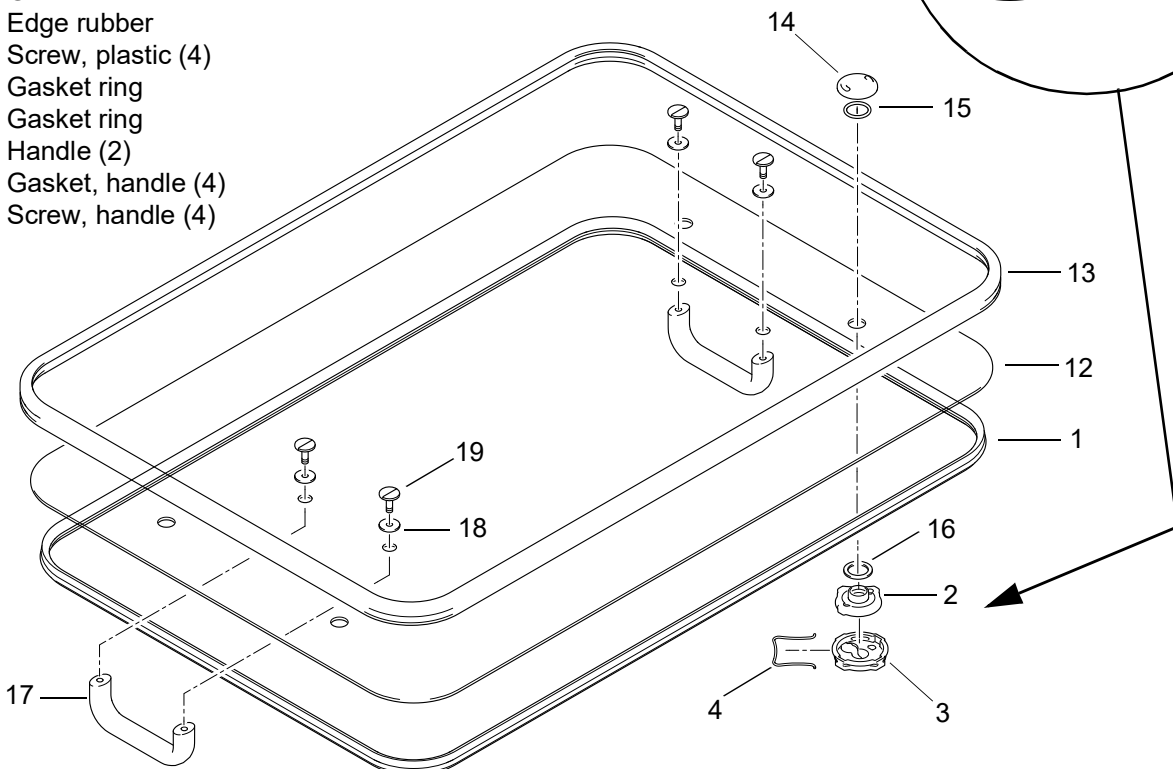

Fig. 304 Eleon hatches - components (part 2)

### 3.3 Control unit

The motors of the lifting mechanisms are controlled by the control unit (Fig. 305).

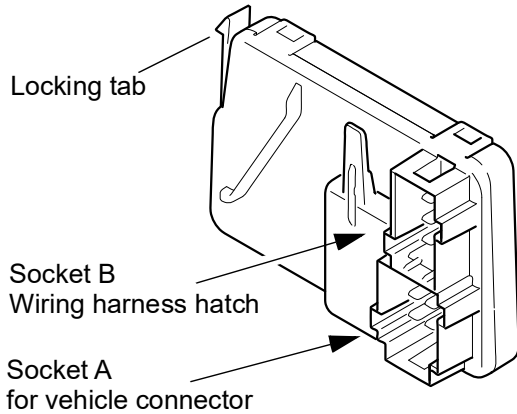

Fig. 305 Control unit

The control unit evaluates the current consumption of the individual motors and generates appropriate switching signals.

### 3.4 Hatch cover

#### *Plastic hatch cover*

The cover consists of two glued half shells. The bottom shell has a compartment with a cover. In this compartment, behind the cover is a red emergency opening lever. The wires of the emergency release are integrated in the cover and can not be replaced separately (only version with emergency release).

Furthermore, at the front and rear of the lower shell are recessed grips embedded.

The top has a red handle in a hollow for emergency opening of the hatch from the outside.

#### *Glass hatch cover*

The cover is made of single-pane safety glass.

At the underside of the hatch cover, the holder for the emergency hammer is centered mounted (only variants with emergency hammer).

In the manual version, a handle is bolted to the underside of the hatch cover at the front and rear.

### 3.5 Interior trim

The interior trim is used to cover the roof cutout. It is bolted to the aluminum frame or secured by special retaining clips. It is removed for service and repair work on the hatch. The main components of the hatch are then accessible.

## 4 Hatch functions

### 4.1 Eleon and Eleon Clear

These hatches are operated by hand. They can be opened at the front side and / or at the rear.

**NOTE:**

The Eleon ventilation and emergency escape hatch Operating instructions contain safety instructions and other information about operating the hatch.

The hatch cover is attached to 4 lifting mechanisms: two at the front and two at the rear side.

By a force on the front handle upwards, in the two front lifting mechanisms lever arrangements are deployed upward - the front part of the hatch cover is raised.

Each lifting mechanism contains a tension spring. When opening the hatch, the spring force must first be overcome. After exceeding the dead point (toggle action principle), the spring supports the opening process and ensures that the hatch remains in the open state.

Conversely, when pulling the front handle of the open hatch, the lever linkage of the two front lifting mechanisms is folded down together. The opening force created by the spring must first be overcome until the hatch is pulled into the closed position. The closing pressure ensures a tight fit of the hatch cover on the seal in the closed position.

### 4.2 Eleon Comfort and Clear Comfort

These hatches are electrically operated and controlled via a control panel (Driver Unit via S-Bus), switch with operating display or CAN bus. They can be opened at the front side and / or at the rear.

**NOTE:**

The Eleon ventilation and emergency escape hatch Operating instructions contain safety instructions and other information about operating the hatch.

The hatches have an opening mechanism in each corner of the frame with electric motor, gear and lever mechanism.

Each of the lifting mechanisms raises (opening) or lowers (closing) a cover carrier, while in the direction of travel front and / or rear lifting mechanisms work synchronously.

The cover carriers are attached to the hatch cover. An electric motor generates a linear movement via a spindle. This is converted via levers in a lifting or lowering movement of the cover carrier.

### 4.2.1 Control unit

The control of the 4 mutually independent lifting mechanisms with one motor each is done by the controller.

There are 3 control unit variants. They differ by the operating voltage range and the communication interface to the vehicle.

Variant	Designation	Voltage	Possible control sources		
			CAN	Switch	S bus (DU)
Variant I	CAN	24V	X		
Variant II	S bus 12V	12V		X	X
Variant III	S bus 24V	24V		X	X

The two control inputs of the control unit have two functions:

1. Variant I has inputs for addressing the CAN bus messages.  
As a result, on one CAN bus can be controlled up to four roof hatches independently of each other.
2. Variant II and III have switch inputs. If a control voltage is present at the input, the roof hatch is raised at the front or at the rear.

### 4.2.2 Control principle

The motors M1 and M4 control the front lifting mechanisms and the motors M2 and M3 the rear lifting mechanisms.

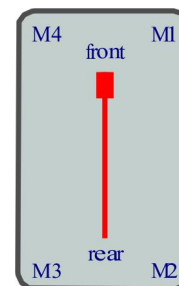

Since the motors are designed for a nominal voltage of 12V, the motors are operated with a PWM frequency at which the effective voltage is limited. The two lifting mechanisms at front and rear are always controlled simultaneously.

If the lifting mechanism is activated, the motor current is continuously monitored. If the motor current increases strongly, the motors are switched off. If the end position is not reached within a certain time window, the motor is also switched off.

**4.2.3 Operating indicator**

The hardware versions II and III have a lamp output which reflects the condition of the roof hatch.

If the roof hatch is closed, the operating indicator is off.

When the roof hatch is open, the operating indicator is switched on.

If an error occurs, a flash code is generated.

For variant I, this operating indicator output is not available, here all information is transmitted via the CAN bus.

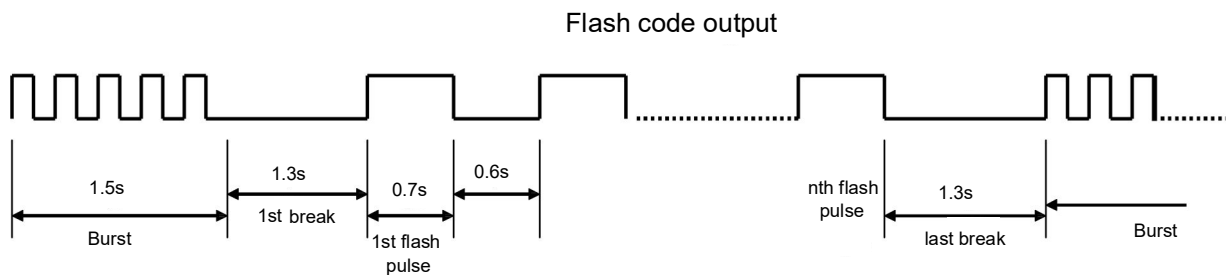











Fig. 401 Flash code at the operating indicator

Flash code	Description of malfunction
0	Control unit malfunction (hardware CD defective)
1	Low voltage or overvoltage
2	Malfunction of one of the 4 drive units

**4.2.4 Control sequence**

Depending on the desired hatch position there are different functional sequences. In order to reduce bending of the hatch cover and mechanical stresses within the lifting mechanisms, first one side of the hatch is slightly raised before the opposite side moves up (for sequence, see table). When closing this step is omitted.

Control sequence	Open hatch front side (ca. 15s)	Open hatch rear side (ca. 15s)	Open hatch completely (ca. 30s)
<b>Step 1</b>	Rear part lifts slightly	Front part lifts slightly	Rear part lifts slightly
			
<b>Step 2</b>	Front part opens completely	Rear part opens completely	Front part opens completely
			
<b>Step 3</b>	Rear part lowers again	Front part lowers again	Rear part opens completely
			

## 5 Troubleshooting

### 5.1 General

 <b>Warning!</b>	<b>Danger to life and health!</b>
---	-----------------------------------

The safety instructions and regulations of Chapter 1 (see 1.6 ) must be observed.

This section describes troubleshooting and error correction for Eleon ventilation and emergency escape hatches.

Error detection is usually limited to localizing the faulty component.

**ATTENTION:**

Prior to replacing a fuse, troubleshooting needs to be performed. The hatch must be disconnected from the vehicle electrical system  
 A properly dimensioned fuse must be inserted (see chapter 6 Wiring diagrams).

After each error correction a functional test must be performed in the vehicle.

### 5.2 General error symptoms

The following table lists possible, general error symptoms.

Kind of operation	Error symptom	Possible cause	Error correction
electrically	hatch does not open / close	no power supply	<ul style="list-style-type: none"> <li>- switch on vehicle main switch</li> <li>- check fuse, replace if necessary</li> <li>- examine contacts, replace if necessary</li> <li>- corrosion on plugs</li> <li>- loose plug connections</li> <li>- crimp failures on plugs and/or pins</li> <li>- corrosion on cable and fuses</li> <li>- corrosion on battery terminals</li> <li>- cable insulation damage</li> <li>- damage to contacts due to frequent plugging in and out.</li> <li>- measure voltage on the control device input</li> </ul>
		cable disconnected or damaged	- check cable connection between lifting mechanism and control unit, replace if necessary
		lifting mechanism runs asynchronously	- check if a lifting mechanism is blocked or if a motor is defective, manual operation possible (see 5.6)
		control unit defective	replace control unit

- Continued on next page -

Kind of operation	Error symptom	Possible cause	Error correction
electrically	movement stops repeatedly	sluggishly	- check mechanical components for sluggishness, replace if necessary - Check if cover is mechanically blocked
		plug connection to the lifting mechanism defective	Check connector and contacts, repair if necessary
		cable damaged	Check cable and replace if necessary
		alternating voltage interruptions, operating voltage not stable	- check operating voltage - Check connector and contacts, repair if necessary
		lifting mechanism defective or too sluggish	replace lifting mechanism
		control unit defective	replace control unit
manually / electrically	ingress of moisture while hatch is closed	hatch seal defective, permeable or worn	replace seal
		moisture ingress via external emergency lever	install new emergency handle lock and actuation cables
		lifting mechanism defective	replace lifting mechanism
	noises	defective mechanism or parts thereof	- check individual parts of the mechanism for damage - missing safety pin
manually	hatch does not open / close or end position not stable	lifting mechanism defective	check levers and spring for damage

### 5.3 Functional check of the hatch

#### 5.3.1 Roof hatch - operated manually

1. Open hatch front side  
The hatch cover must be able to open at the front side evenly, without unilateral resistances, without abnormal noises and horizontally. After that, the cover is open at front side about 7cm.
1. Open rear side  
The hatch cover must be able to open at the rear side evenly, without unilateral resistances, without abnormal noises and horizontally. After that, the cover is at all sides about 7cm open.
2. Close front side  
The hatch cover must be able to close at the front side evenly, without unilateral resistances, without abnormal noises and horizontally.
3. Close rear side  
The hatch cover must be able to close at the rear side evenly, without unilateral resistances, without abnormal noises and horizontally.  
After that the hatch cover sits evenly close on the hatch seal on all sides.

#### 5.3.2 Roof hatch - operated electrically

1. Check the control sequence of the roof hatch (see 4.2.4). Pay attention to the following:
  - The hatch cover moves smoothly, without any stoppages and abnormal noises into the desired position.
  - The motors 1/4 and / or 2/3 work synchronously.
  - The operating indication (depending on the variant) corresponds to the position of the hatch cover.
  - The opening gap at the front / rear or on all sides is approx. 6cm.
2. When closed, the hatch cover sits evenly close on the hatch seal on all sides.

### 5.4 Visual inspection of a lifting mechanism

#### 5.4.1 Lifting mechanism - operated manually

1. Remove lifting mechanism from hatch (see 8.5).
2. Check all moveable parts for damage and their correct arrangement and bearing.

#### 5.4.2 Lifting mechanism - operated electrically

1. Remove lifting mechanism from hatch (see 8.5).
2. Check all moveable parts for damage and their correct arrangement and bearing.
3. Are the plug and the cables to the motor visible damaged?
4. Check the correct position of the spindle and its condi-

tion (corrosion, mechanical damage, dirt deposit).

### 5.5 Checking the motor of a lifting mechanism

1. Remove lifting mechanism from hatch (see 8.5).
2. Inspect the mechanism visually (see 5.4.2).
3. Test the motor by applying 12V DC with a duration of max. 5s (Attention, also the 24V variant). Check both directions of rotation by reversing the polarity. In the event of a malfunction, replace the lifting mechanism.

### 5.6 Manual adjustment of the electrically operated lifting mechanism

The height of the cover carrier of a lifting mechanism can be readjusted manually in each of the end positions. Proceed as follows:

1. Disconnect the roof hatch from the vehicle electrical system.
2. Remove the screws securing the hatch interior trim and remove the trim.
3. Locate the hole in the bottom of the lifting mechanism (see Fig. 501), insert an Allen wrench (6mm) and turn it in the desired direction
  - clockwise - cover carrier moves down
  - counterclockwise - cover carrier moves up.

**NOTE:**

Consider the mark on the hole for the Allen wrench.

4. Reconnect the roof hatch from to the vehicle electrical system.
5. Check the correct function of the hatch.
6. Place the interior trim into position and secure using screws.



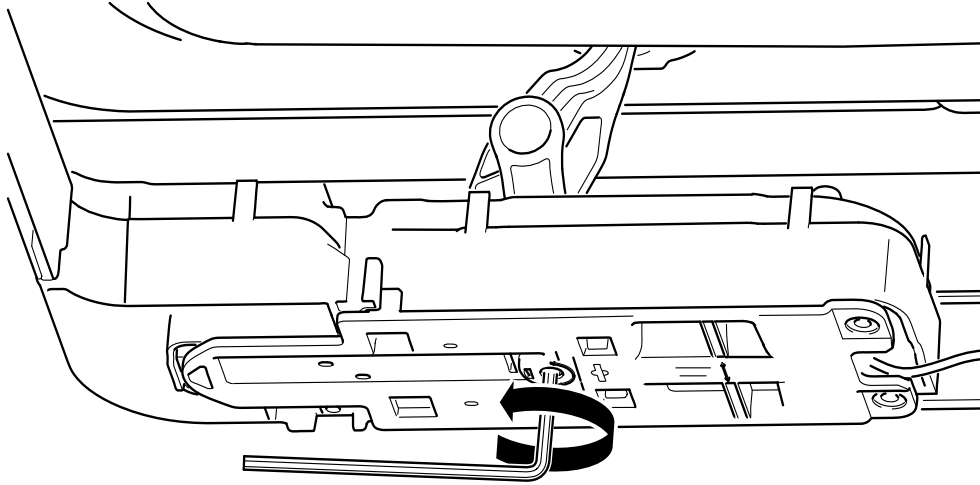

Fig. 501 Manual readjustment

## 6 Wiring diagrams

### 6.1 General

The following illustrations show the wiring variants of the electrically operated roof hatch to the vehicle electrical system as well as the connector pin assignment.

Fig. 601 - Connector data and pin assignment / hatch and motor numbering

Fig. 601 - Wiring diagram 1..4 roof hatches using switches

Fig. 601 - Wiring diagram 1..4 roof hatches via S bus using control panel "Driver unit"

Fig. 601 - Wiring diagram 1..4 roof hatches via CAN bus

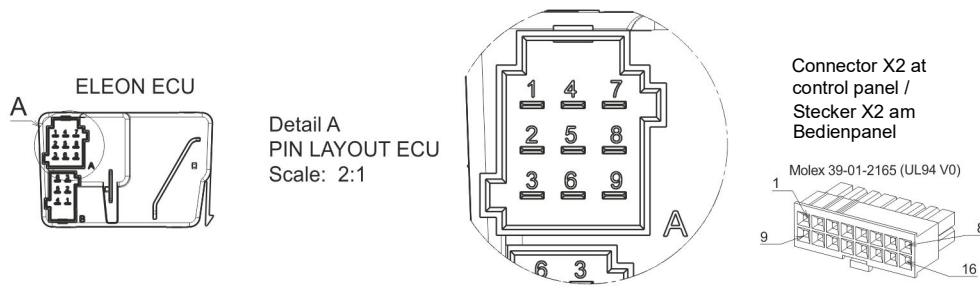

Mating plug / Gegenstecker

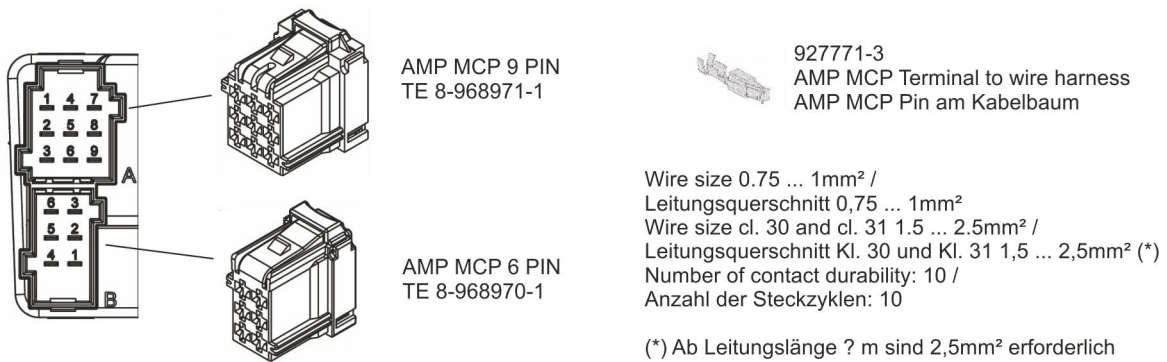

Table pinning / Tabelle Pinbelegung

Pin	Connector A (vehicle)		Connector B (roof hatch)
	Variant I / Variante I	Variant II and III / Variante II und III	
1	Cl. 30, plus / Kl. 30, Plus	Cl. 30, plus / Kl. 30, Plus	M1, Motor front right (red)
2	Cl. 31, ground / Kl. 31, Masse	Cl. 31, ground / Kl. 31, Masse	M2, Motor rear right (red)
3	A0 address input / A0 Adresseingang	A0/E1 address or control input (E1 = rear open) / A0/E1 Adress- bzw. Steuereingang (E1 = hinten auf)	M3, Motor front left (red)
4	A1 address input / A1 Adresseingang	A0/E2 address or control input (E2 = front open) / A1/E2 Adress- bzw. Steuereingang (E2 = vorne auf)	M1, Motor front left (red)
5	CAN-H input / CAN-H ankommend	to lamp / Lampenausgang	M1 / M2 (black)
6	CAN-L input / CAN-L ankommend	S-Bus	M3 / M4 (black)
7	CAN-H output / CAN-H abgehend	to lamp / Lampenausgang	--
8	CAN-L output / CAN-L abgehend	S-Bus	--
9	120R-CAN-H	not used / nicht belegt	--

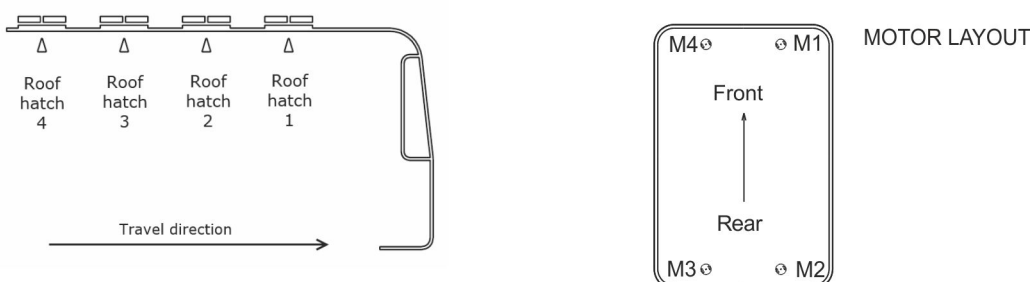

Fig. 601 Connector data and pin assignment / hatch and motor numbering

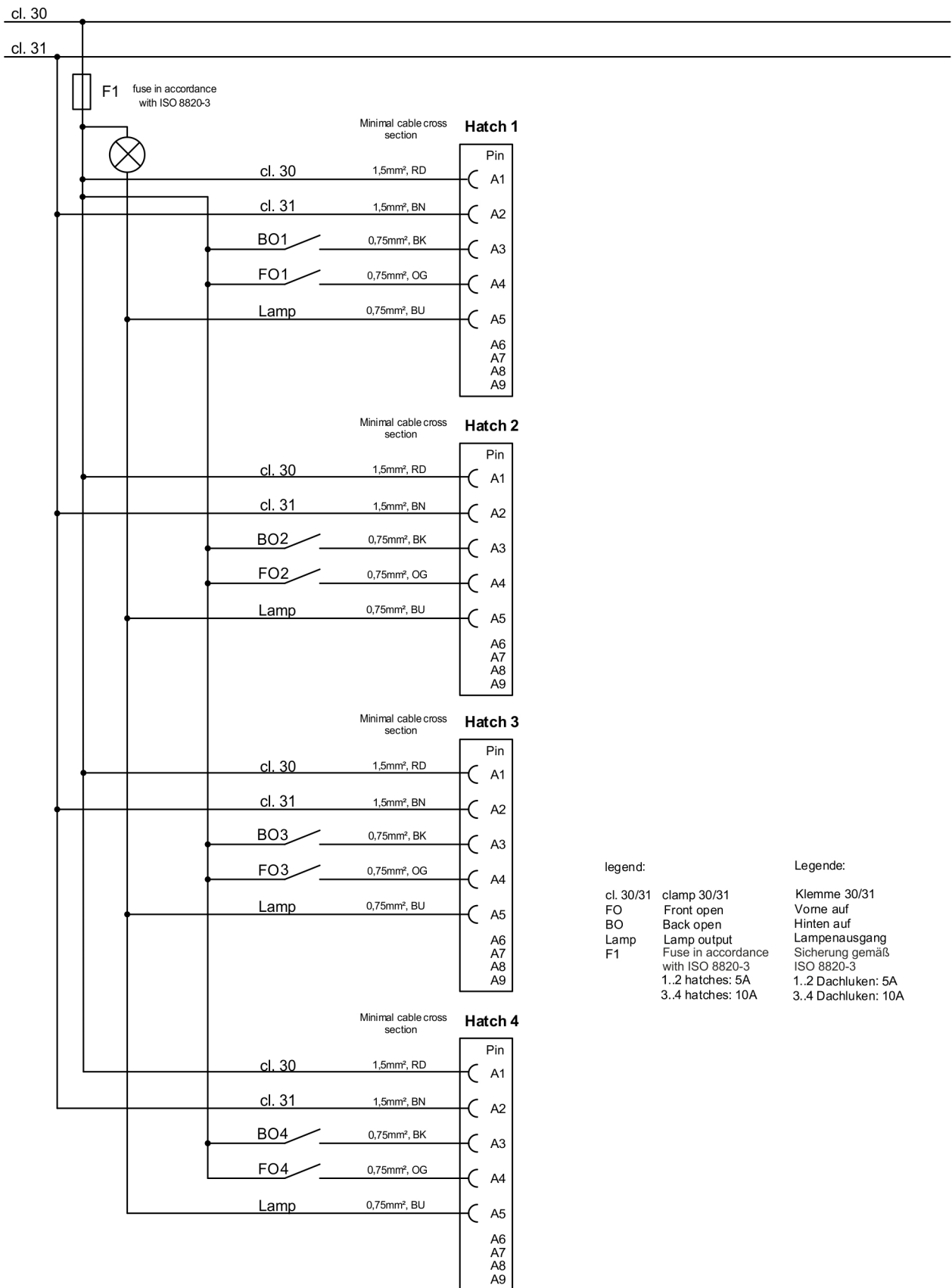

Fig. 601 Wiring diagram 1..4 roof hatches using switches

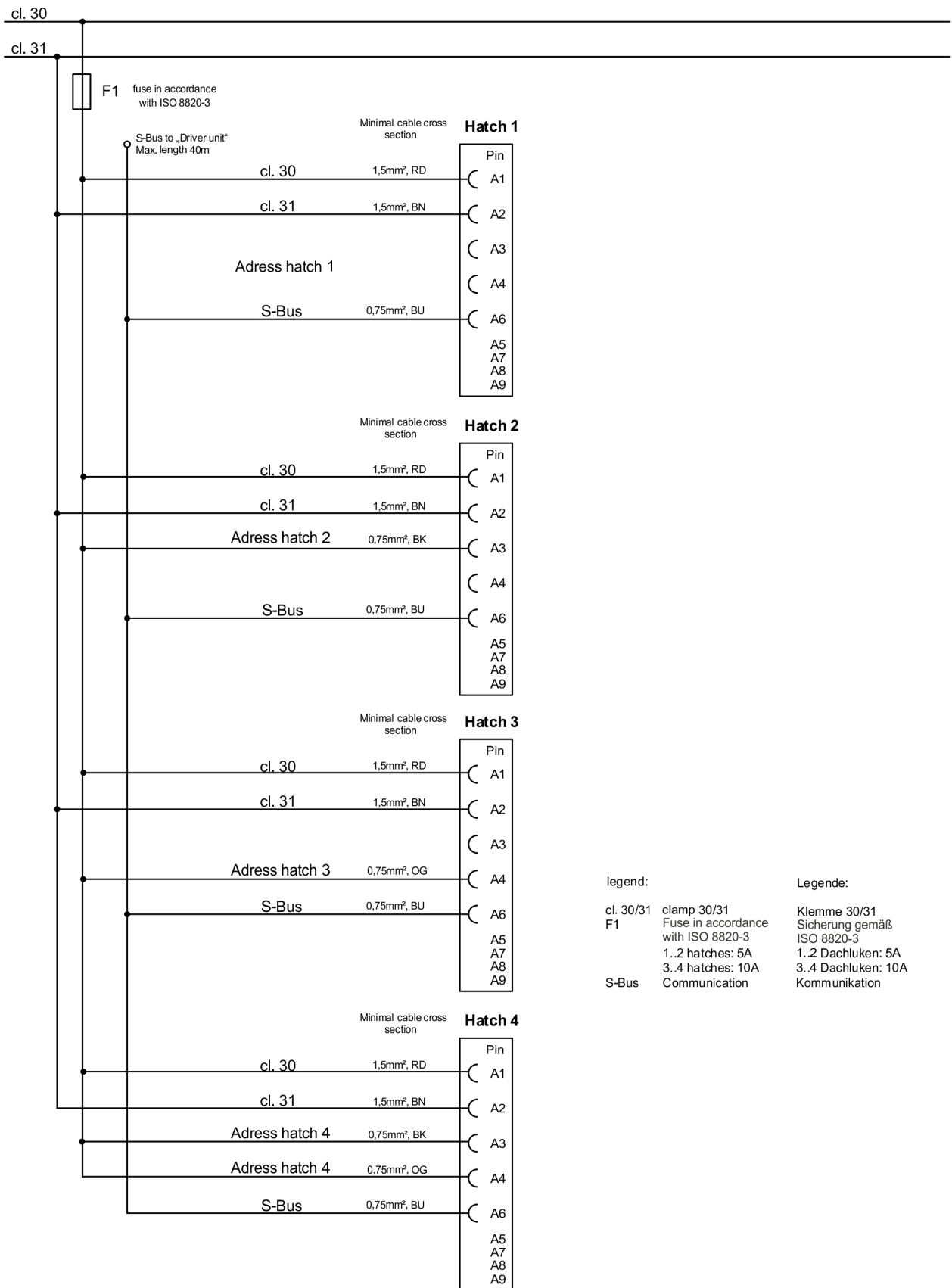

Fig. 601 Wiring diagram 1..4 roof hatches via S bus using control panel "Driver unit"

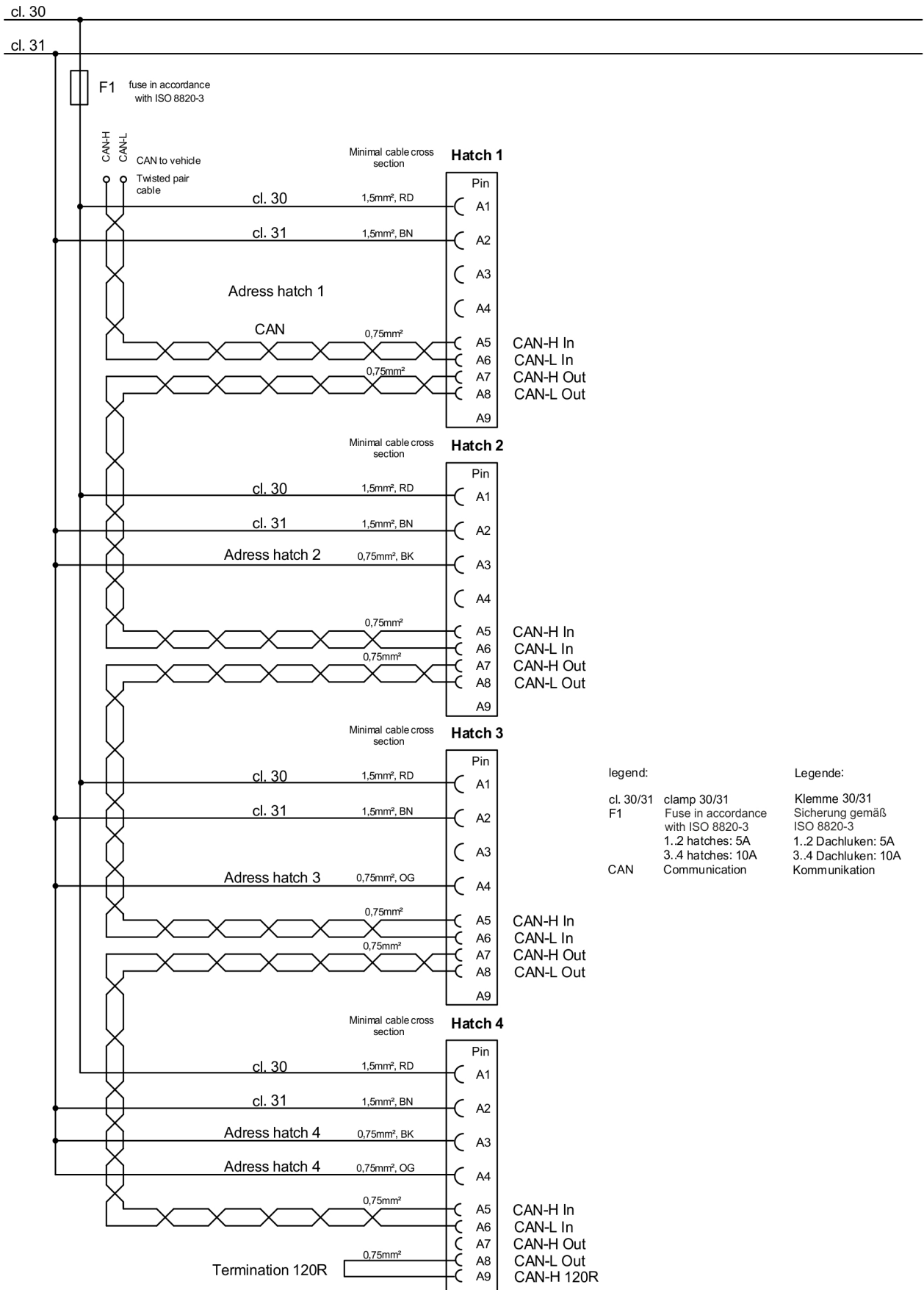

Fig. 601 Wiring diagram 1..4 roof hatches via CAN bus

## 7 Servicing

### 7.1 General



The safety information and regulations in Chapter 1 (see 1.6 ) must be adhered.

The scope of service work on the roof hatches is limited to their cleaning.

### 7.2 Cleaning of the roof hatches

Before the roof hatch is cleaned from the outside, it is advisable to open and close the roof hatch completely to ensure that the roof hatch is completely closed.

The cleaning of the roof hatch may be carried out as for the other similar external surfaces of the bus and by the same means as e.g. for windows with seals.

Further information can be found in the section Exterior cleaning of the bus in the service documentation of the vehicle manufacturer.

## 8 Components removal and installation

### 8.1 General



The safety information and regulations in Chapter 1 (see 1.6 ) must be adhered.

#### ATTENTION:

Prior to disassembling components the hatch must be disconnected from the vehicle electrical system

#### NOTE:

If components are disassembled to a degree not covered in this workshop manual, any warranty claim shall be voided.

Only genuine Spheros spare parts should be used.



Symbol tightening torque value:  
Identifies in graphics parts (eg nuts, bolts) that are to be mounted with a specific tightening torque. The torque values are shown at the symbol and are binding.



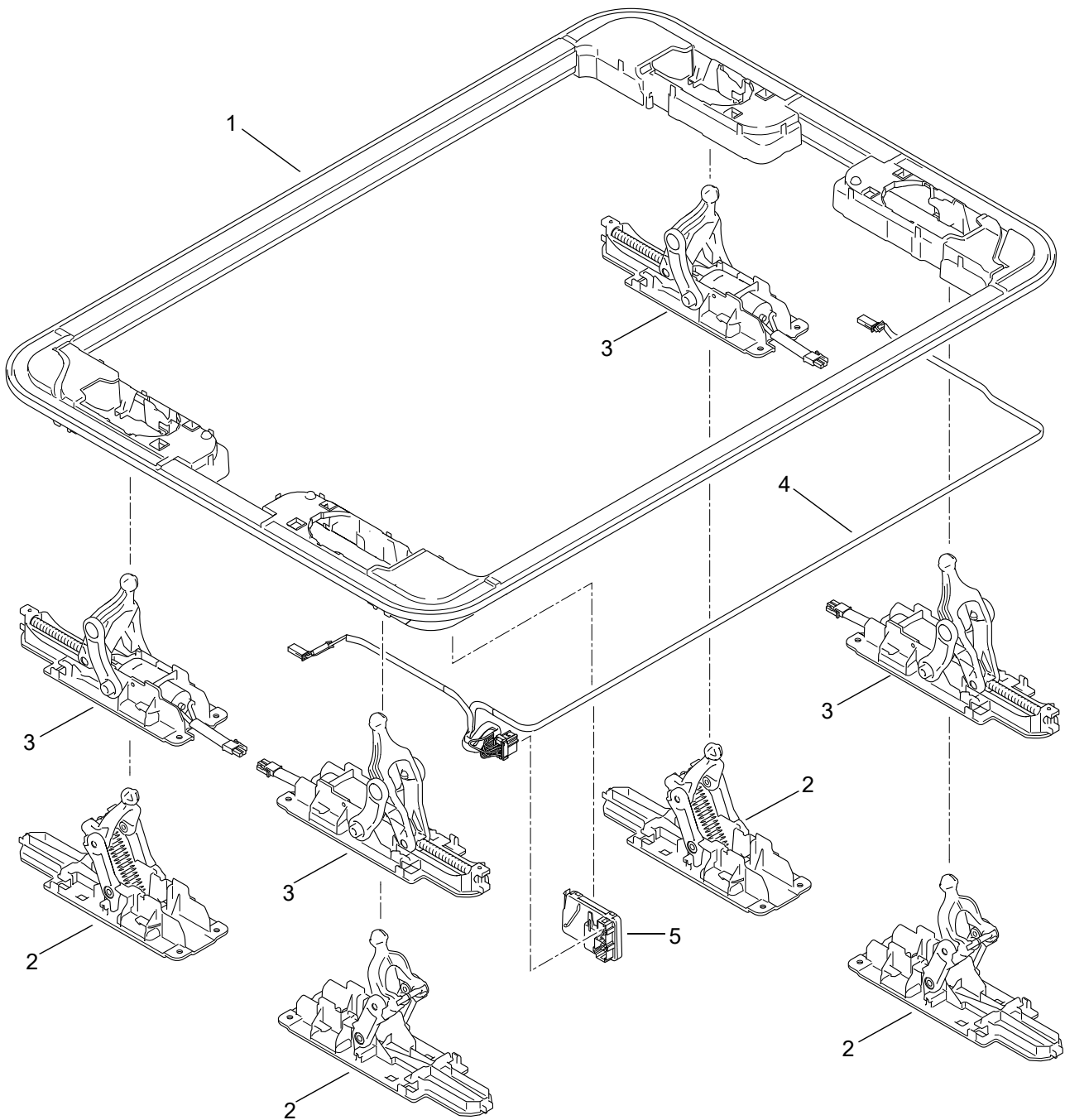

Hatch with plastic/glass cover - manually operated:

- 1 Frame
- 2 Lifting mechanism, manually operated

Hatch with plastic/glass cover - electrically operated:

- 1 Frame
- 3 Lifting mechanism, electrically operated
- 4 Wiring harness
- 5 Control unit

Fig. 801 Eleon hatches - Components (part 1)

Hatch with plastic cover:

- 1 Seal
- 2 Cover carrier, upper part (4)
- 3 Cover carrier, lower part (4)
- 4 Retaining clip (4)
- 5 Screw (8)
- 6 Cover body
- 7 Emergency handle, outer
- 8 Gasket ring
- 9 Emerg. handle, inner
- 10 Screw
- 11 Covering

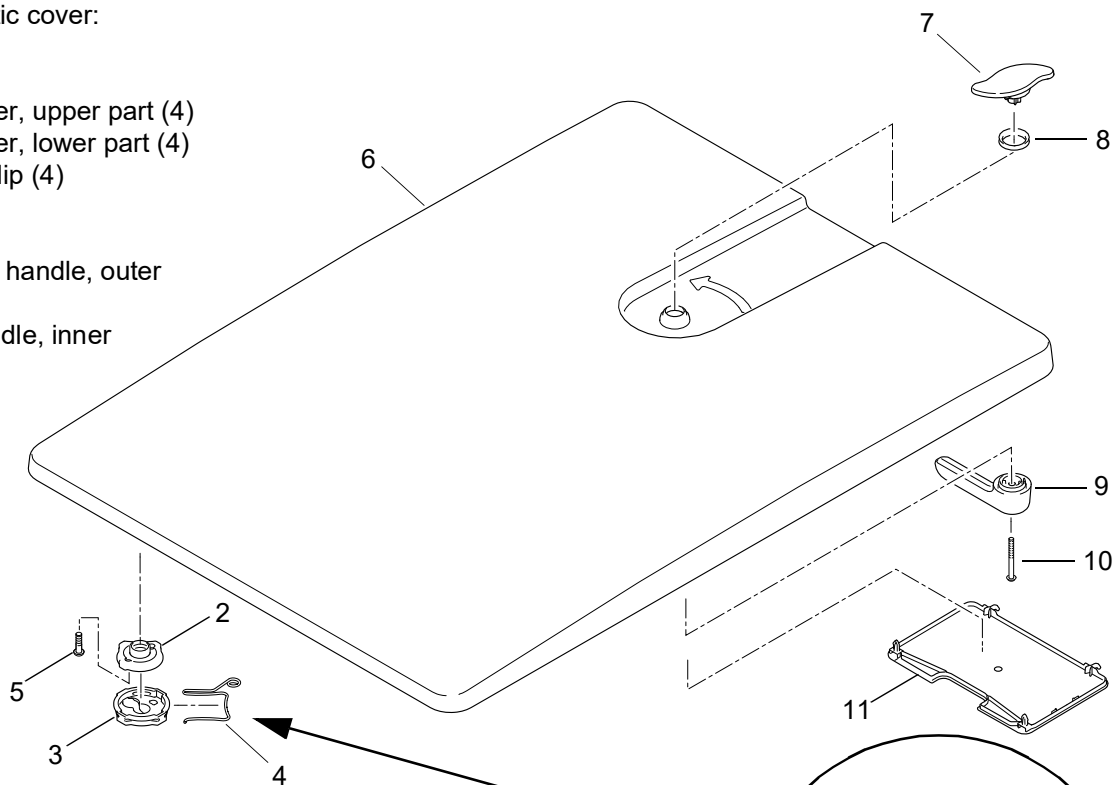

Hatch with glass cover:

- 1 Seal
- 2 Cover carrier, upper part (4)
- 3 Cover carrier, upper part (4)
- 4 Retaining clip (4)
- 12 Glass
- 13 Edge rubber
- 14 Screw, plastic (4)
- 15 Gasket ring
- 16 Gasket ring
- 17 Handle (2)
- 18 Gasket, handle (4)
- 19 Screw, handle (4)

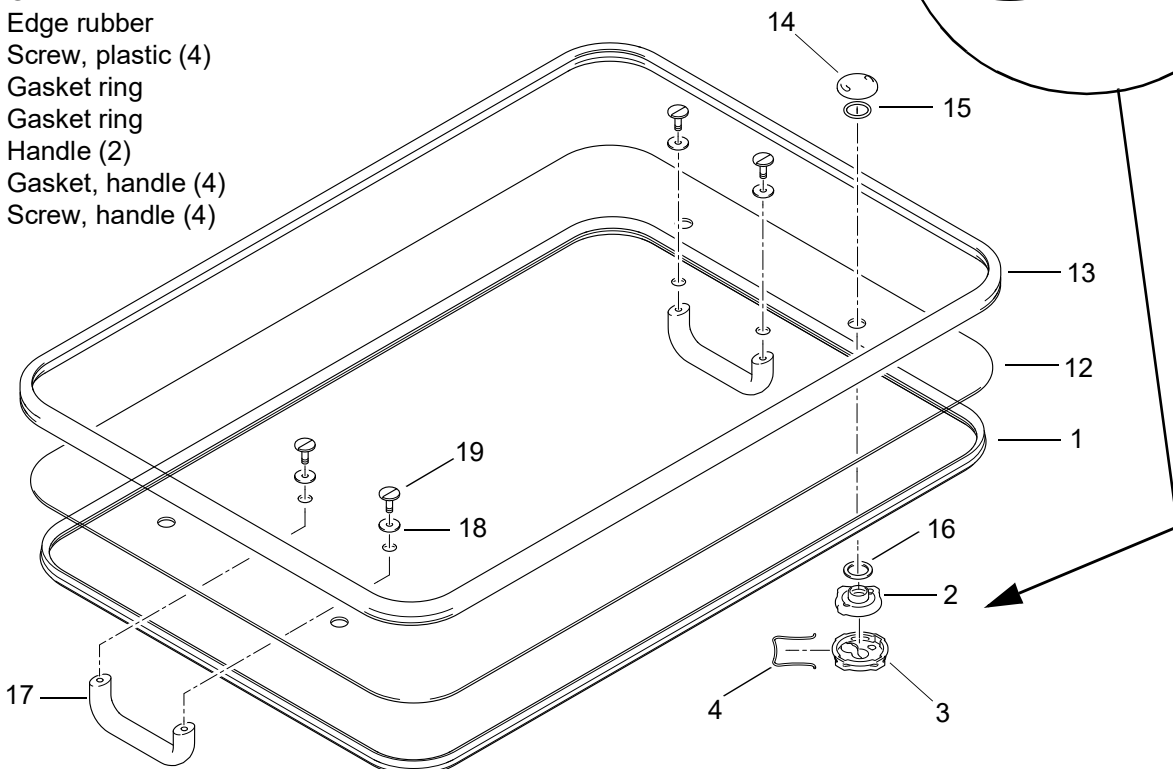

Fig. 802 Eleon hatches - Components (part 2)

## 8.2 Seal removal and installation

### Removal

1. Open the roof hatch completely.
2. Remove the seal (1, Fig. 802) from its groove in the frame (1, Fig. 801) by pulling it upward all around the roof hatch.
3. Lift one end of the seal loop onto the top of the cover and remove the seal from the roof hatch.

### Installation

1. Clean the groove.
2. Place the new seal (1, Fig. 802) onto the hatch frame. Locate the seal so that the vulcanized seam is in the first quarter of a long frame side, the seal lip must point outwards (see Fig. 803).

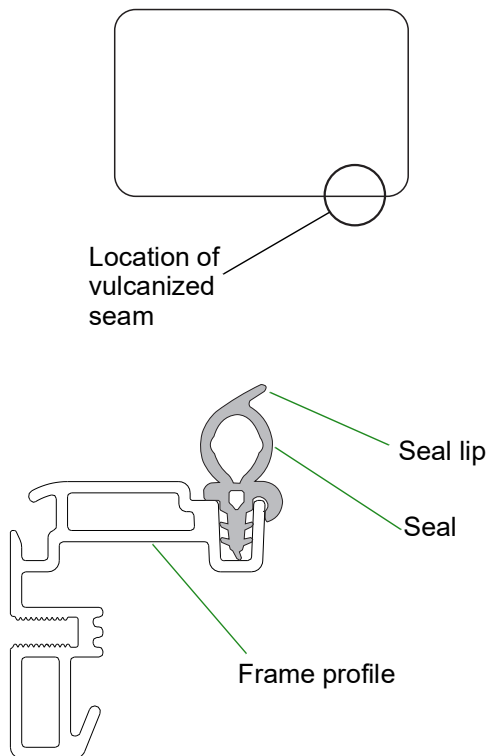

Fig. 803

3. Then, install the seal into all 4 corners so that the seal is stretched evenly.
4. Install the remaining seal into the groove.

### NOTE:

Make sure that the seal is pressed to the bottom of the groove.

### NOTE:

If the loop is too long or too short, loosen the seal from the groove at the area where the length needs to be readjusted.

Depending on the length pull or push the seal and re-install it into the groove.

5. After the assembly of the seal, operate the roof hatch through its full cycles a couple of times and check that the seal stays in its groove.

### NOTE:

A water leakage test is recommended to be done after installing a new seal.

## 8.3 Cover assembly removal and installation (glass cover)

### Removal

1. Open the roof hatch completely.
2. Pull retaining clips (4, Fig. 802) from all 4 cover carriers (2, 3).
3. Remove cover assembly.

### Installation

1. Position cover assembly onto the lower parts (3, Fig. 802) of the cover carriers.
2. Starting at a corner, use one hand to connect the cover carrier (2, 3) and use the other hand to insert the retaining clip (4) into the cover carrier.
3. Repeat the procedure on the remaining cover carriers.

### NOTE:

Make sure all retaining clips (4) are installed properly. They must be pushed to bottom and from correct direction.

### 8.4 Cover assembly removal and installation (plastic cover)

#### Removal

1. Open the roof hatch completely.
2. Disconnect cover assembly from the lower parts (3, Fig. 802) of the cover carriers.

Roof hatch without emergency opening system:

- Pull retaining clips (4) from all 4 cover carriers.

Roof hatch with emergency opening system:

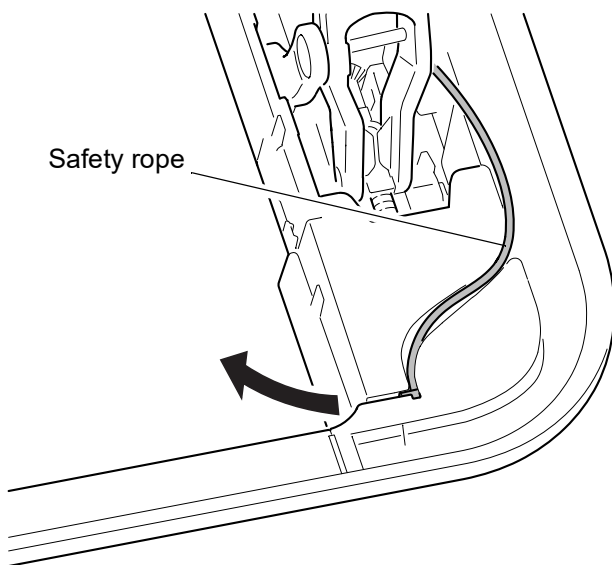
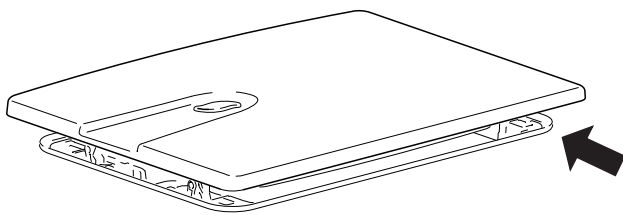

Fig. 804

- Turn the emergency opening lever (9) from the inside clockwise until the stop.

3. Unhook safety rope (Fig. 804) from its holder. Hold the hatch cover as close to the frame as possible to facilitate unhooking of the safety rope.
4. Remove the hatch cover.

#### Installation

1. Hook in the safety rope (Fig. 804) into the holder.
2. Position cover assembly onto the lower parts (3, Fig. 802) of the cover carriers.

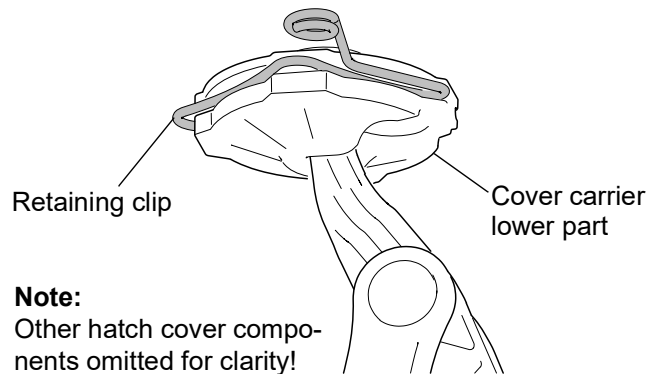

Fig. 805 Retaining clip in position

3. Starting at a corner, use one hand to connect the cover carrier (2, 3) and use the other hand to insert the retaining clip (4) into the cover carrier.
4. Repeat the procedure on the remaining cover carriers.

#### NOTE:

Make sure all retaining clips (4) are installed properly. They must be pushed to bottom and from correct direction (see Fig. 805).

### 8.5 Lifting mechanism removal and installation

#### Removal

1. Open the roof hatch completely.
2. Unplug the plug to the motor (see Fig. 302, electrically operated opening mechanisms only).
3. Pull retaining clip (4, Fig. 802) out from the cover carrier (2, 3).
4. Insert disassembly tool P/N 8610291\_ into the both holes at the bottom of the lifting mechanism (see Fig. 806).
5. Push the tool up and simultaneously slide the mechanism in the direction of the motor connector.

#### NOTE:

By the disassembly tool two locking tabs (see Fig. 302) are pushed upwards, which allows the sliding out of the complete lifting mechanism from its holder.

6. Once the release mechanism has moved slightly, remove the disassembly tool.
7. Pull the lifting mechanism completely out of its holder and remove it downwards out of the frame.

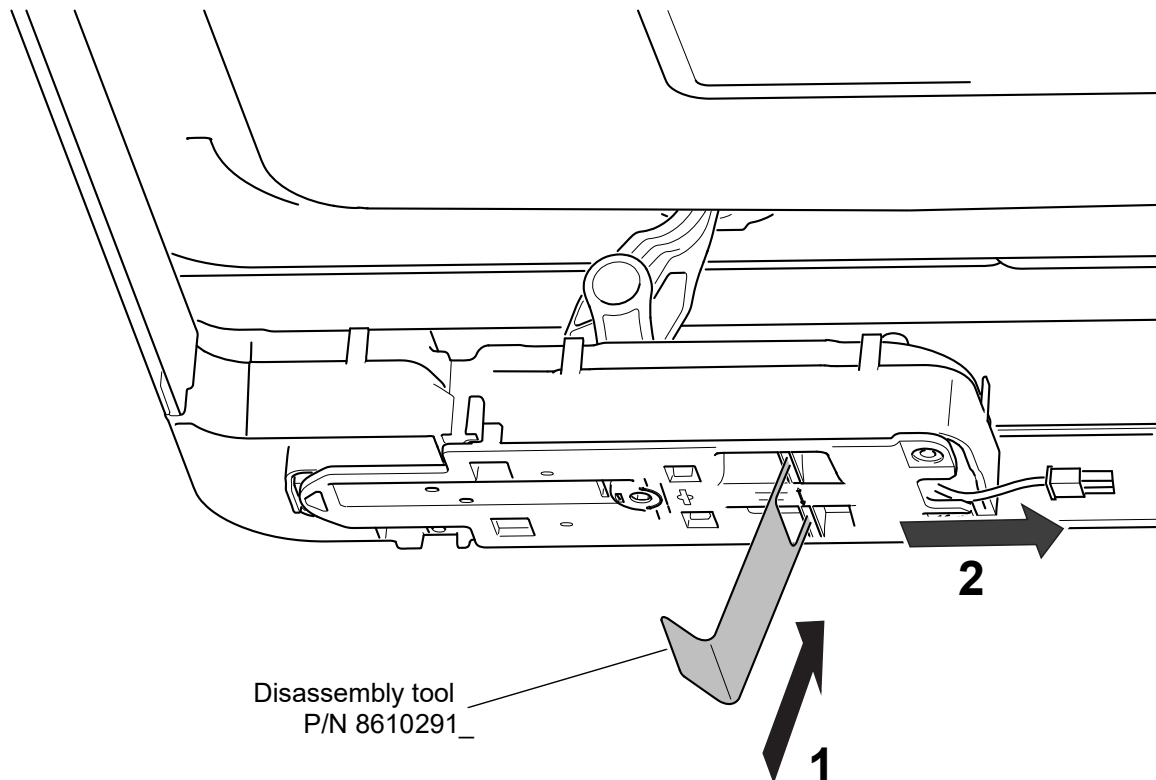

Fig. 806

### Installation

1. Insert the lifting mechanism (2 or 3, Fig. 801) from below into the corner section and push it in the direction of the corner until it snaps into place.
2. Position the lower part of the cover carrier (3, Fig. 802) onto the ball head of the lifting mechanism and place the upper part of the cover carrier (2) onto it.
3. Insert retaining clip (4) into the cover carrier.

#### NOTE:

For hatches with plastic cover, pay attention to the installation direction of the clip (emergency release).

4. Connect motor plug (electrically operated opening mechanisms only).
5. After installation of the lifting mechanism, open and close the hatch several times and check that the lifting mechanism works correctly.

## 8.6 Control unit removal and installation

### Removal

1. Disconnect hatch from vehicle electrical system, for example pull F1 fuse (see chapter 6).
2. By means of a for example screwdriver, push in the locking tab on top of the control unit bracket (see Fig. 305) and pull out the control unit (5, Fig. 801) downwards.
3. Disconnect the two plugs from the control unit.

### Installation

1. Plug the two connectors (see Fig. 305) into the control unit.
2. Slide control unit upwards into its bracket until it snaps into place.
3. After installation of the control unit, open and close the hatch several times and check that the hatch works correctly.

## 8.7 Wiring harness removal and installation

### Removal

1. Open the roof hatch completely.
2. Remove the control unit (see 8.6).
3. Disconnect all motor connectors (see Fig. 302).
4. Start with detaching the cable harness (4, Fig. 801) from the two corner pieces and lift the cable straight up.
5. Continue with detaching the cable harness from the aluminium profile groove.
6. Remove wiring harness from hatch frame.

### Installation

1. Install the control unit (see 8.6).
2. Connect all motor connectors (see Fig. 302).
3. Insert the wiring harness in the guides of the corner pieces and in the groove of the aluminum profile (see Fig. 807).
4. After installation of the wiring harness, open and close the hatch several times and check that hatch works correctly.

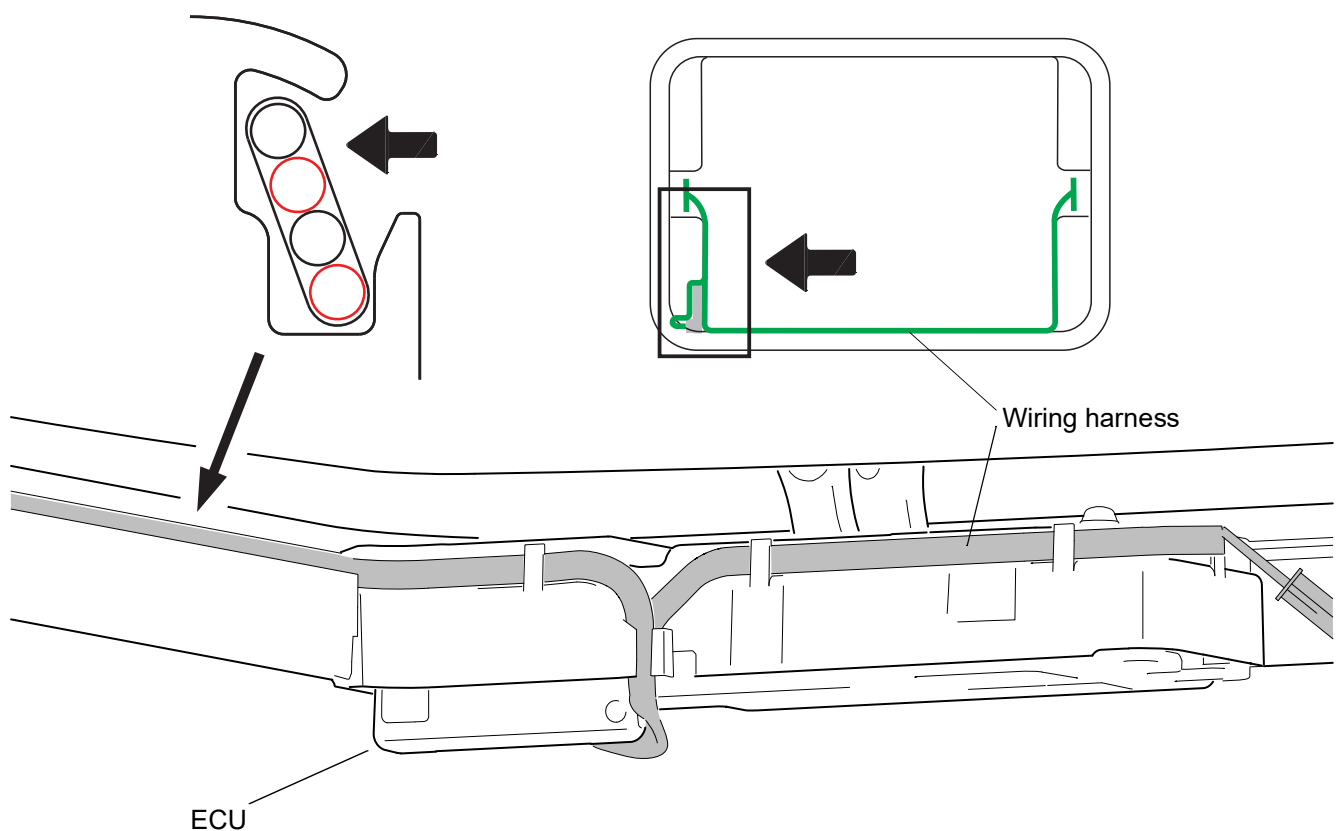

Fig. 807 Wiring harness installation

## 8.8 Emergency hammer removal and installation

This procedure is only necessary if the hammer bracket is damaged or missing.

### Removal

1. Remove the seal.
2. Take the hammer from its bracket.
3. Remove bracket from hatch cover.
4. Remove adhesive residue from the hatch cover.

### Installation

1. Remove the protective foil from the adhesive tape on the bottom of the bracket.
2. Identify the glue mark for the bracket on the hatch cover.
3. Press bracket with at least 100N for at least 3s onto the cover.
4. Install hammer into the bracket.
5. Install seal.

## 9 Modifications and retrofits

For further optimization the roof hatches are continuously improved. Units in the field can usually be upgraded or retrofitted. For this purpose respective modification kits will be available. Information can be found on the Spheros homepage under Service.

## **10 Packing/storage/shipping**

### **10.1 General**

The roof hatch or its components, which are sent to Spheros for inspection or repair, must be cleaned and packaged to ensure that handling, transport and storage will not damage them.





