



HEATING SYSTEMS

Thermo plus 160 / 230 / 300 / 350

Installation instructions

Rev. 05/2023
Id.-No. 11121149D-001

SPHEROS

1	Introduction		5	Circulation pump installation	
1.1	Content and purpose.....	4	5.1	Models.....	16
1.2	Target group.....	4	5.2	Overview of documents.....	16
1.3	Document validity.....	4	5.3	Installation location.....	16
1.4	Overview of documents.....	4	5.4	Installation position.....	16
1.5	Definition of warning notices.....	4			
1.6	Abbreviations used.....	5	6	Connecting the cooling system	
1.7	Definition of symbols.....	5	6.1	Lines for coolant.....	17
1.8	Suggestions for improvement and change.....	5	6.2	Filling and venting the circuit.....	17
2	Safety notes and provisions		7	Fuel system	
2.1	General safety notes.....	6	7.1	Lines for fuel.....	18
2.1.1	Installation and maintenance.....	6	7.1.1	Permissible fuel line dimensions.....	18
2.1.2	Start-up and operation.....	6	7.2	Prefilling and venting the fuel system.....	19
2.2	Legal provisions for installation.....	7	7.3	Fuel filter.....	19
3	Overview of heater		7.4	Permissible vacuum in fuel system (at the heater inlet for fuel).....	19
3.1	Intended use.....	9	8	Combustion air supply	
3.2	Models.....	9	8.1	Line for combustion air.....	20
3.3	Function.....	9	9	Exhaust pipe	
3.4	Description and dimensions.....	10	9.1	Exhaust pipe.....	22
3.5	Type label.....	11	10	Electrics and electronics	
4	Heater installation		10.1	Prerequisites for electrical connections.....	24
4.1	Installation location.....	12	10.1.1	Ripple voltage.....	24
4.1.1	Installation space.....	12	10.1.2	Load dump protection.....	24
4.2	Installation position.....	13	10.1.3	Power supply.....	24
4.3	Installation example.....	15			

1 Introduction

1.1 Content and purpose

These installation instructions describe the installation of the following heaters:

- Thermo plus 160
- Thermo plus 230
- Thermo plus 300
- Thermo plus 350

1.2 Target group

Work on the heater may only be performed by personnel that has been trained and/or instructed by Spheros.

The current training courses are listed at www.spheros.com.

1.3 Document validity

The German-language version is binding in multilingual editions. Subject to change without notice.

1.4 Overview of documents

For information on the installation, operation and maintenance of the heater, use the following documents:

- Installation instructions
- Operating instructions
- Workshop manual
- Maintenance plan
- Spare parts list
- Accessories catalog

The current versions are listed in the Download Center at www.spheros.com. Additional documents on the heater can also be found there.



1.5 Definition of warning notices

In this document, certain topics are highlighted using specific wording and styles. The following examples show how they are implemented in the document.

WARNING

Type and source of danger!

Indicates a dangerous situation which, if not avoided, may lead to death or serious injury.

CAUTION

Type and source of danger!

Indicates a dangerous situation which, if not avoided, may lead to light to moderate injuries.

ATTENTION

Indicates procedures which may lead to property damage.

NOTICE

Indicates a special feature.

1.6 Abbreviations used

Abbreviation	Meaning
BA	Operation indicator
BM	Burner motor
DIN	German Institute for Standardization
DTT	Diagnostic Thermo Test
DVW	Nozzle block preheater
ECE	Economic Commission for Europe
EL	Extra light
EMC	Electromagnetic compatibility
EN	European norm
F	Fuse
FA	Flame indicator
FAME	Fatty acid methyl ester
HG	Heater
HS	Main switch
HVO	Hydrotreated vegetable oil
ISO	International Organization for Standardization
T.	Terminal
M	Vehicle category for the transportation of passengers
MV	Solenoid valve
N	Vehicle category for the transportation of goods
NHN	Standard elevation zero

Abbreviation	Meaning
O	Vehicle category for trailers
PPE	Personal protective equipment
PT	Platinum temperature sensor
R	Regulation (provision)
Eco	Economy mode
UN	United Nations
UP	Circulation pump
UPFA	External control of circulation pump
ZFG	Ignition spark generator

Tab. 1: Thermo plus abbreviations used

1.7 Definition of symbols



Torque

Identifies parts (e.g., screws) that must be tightened with a specified torque. The torque value is specified on the symbol.

1.8 Suggestions for improvement and change

Do you have any suggested improvements or changes for this document?

Please contact us at www.spheros.com.

2 Safety notes and provisions

The general accident prevention regulations and the applicable industrial safety instructions must be observed.

The "General safety notes" and "Legal provisions for installation" that go beyond the scope of these regulations and instructions are presented below.

2.1 General safety notes

2.1.1 Installation and maintenance

The installation, maintenance or repair of a Spheros heater must properly executed. Improperly executed work can result in fires or in the emission of lethal carbon monoxide.

The following points are necessary for installation, maintenance and repair:

- Spheros training and/or instruction by trained personnel (see *1.2 Target group, Page 4*)
- Technical documentation (see *1.4 Overview of documents, Page 4*)
- Personal protective equipment (PPE) such as safety goggles
- Tools (incl. special tools and measuring equipment)

Spheros accepts no liability for defects and damage that can be attributed to improper installation or improper maintenance or repair by untrained personnel.

Only use original spare parts for maintenance and repair work. If spare parts from third-party suppliers are used, the general operating license and the ECE type approval of the heater expire.

2.1.2 Start-up and operation

The housing of the heater can reach the ignition temperature of diesel fuel (> 250 °C) if the heater is operated without coolant.

The heater must not be operated:

- At gas stations and tank systems.
- In closed spaces (e.g., garage or hall without a fume extraction system).
- If the heater or the outlet for exhaust is located in places where combustible vapors (e.g., near fuel or combustible material storage facilities) or combustible dust (e.g., close to plastic, coal, wood dust or grain storage facilities) forms.
- If the heater or the outlet for exhaust is located near flammable materials (e.g., dry grass, leaves, cardboard or paper).
- If the heater's outlet for exhaust is partially or completely closed off (e.g., by earth or snow, as may happen when a vehicle reverses).

The heater must:

- Be taken out of service if it develops an excessive amount of smoke, makes unusual combustion noises or emits a fuel odor.
- Be checked by personnel that has been trained and/or instructed by Spheros before it is taken back into service.

2.2 Legal provisions for installation

Type approvals for the heaters exist as per the following ECE regulations:

R10 (EMC):

- No. 05 7559

R122 (heater):

- No. 00 0580 for Thermo plus 160
- No. 00 0466 for Thermo plus 230
- No. 00 0467 for Thermo plus 300
- No. 00 0468 for Thermo plus 350

For installation, primarily observe the provisions of ECE Regulation R122 - Annex 7.

NOTICE

The provisions of Regulations R10 and R122 are binding within the scope of the ECE Regulations. In countries without specific regulations, the ECE Regulations must be observed as well.

Excerpt from ECE Regulation R122 - Annex 7:

" ...

4 The heater must have a manufacturer's label showing the manufacturer's name, the model number and type together with its rated output in kilowatts. The fuel type must also be stated and, where relevant, the operating voltage and gas pressure.

(...)

7.1 A clearly visible tell-tale in the operator's field of view shall inform when the combustion heater is switched on or off.

... "

Excerpt from ECE Regulation R122 - Part I:

" ...

5.3 Vehicle Installation Requirements for Combustion Heaters

5.3.1 Scope

5.3.1.1 Subject to paragraph 5.3.1.2, combustion heaters shall be installed according to the requirements of paragraph 5.3.

5.3.1.2 Vehicles of category O having liquid fuel heaters are deemed to comply with the requirements of paragraph 5.3..

5.3.2 Positioning of combustion heater

5.3.2.1 Body sections and any other components in the vicinity of the heater must be protected from excessive heat and the possibility of fuel or oil contamination.

5.3.2.2 The combustion heater shall not constitute a risk of fire, even in the case of overheating. This requirement shall be deemed to be met if the installation ensures an adequate distance to all parts and suitable ventilation, by the use of fire resistant materials or by the use of heat shields.

5.3.2.3 In the case of M2 and M3 vehicles, the combustion heater must not be positioned in the passenger compartment. However, an installation in the passenger compartment in an effectively sealed housing which also complies with the conditions in paragraph 5.3.2.2 may be used.

5.3.2.4 The label referred to in Annex 7, paragraph 4, or a duplicate, must be positioned so that it can be easily read when the heater is installed in the vehicle.

5.3.2.5 Every reasonable precaution should be taken in positioning the heater to minimize the risk of injury and damage to personal property.

5.3.3 Fuel supply

5.3.3.1 The fuel filler must not be situated in the passenger compartment and must be provided with an effective cap to prevent fuel spillage.

5.3.3.2 In the case of liquid fuel heaters, where a supply separate from that of the vehicle is provided, the type of fuel and its filler point must be clearly labeled.

5.3.3.3 A notice, indicating that the heater must be shut down before refueling, must be affixed to the fueling point. In addition a suitable instruction must be included in the manufacturer's operating manual.

5.3.4 Exhaust system

5.3.4.1 The exhaust outlet must be located so as to prevent emissions from entering the vehicle through ventilators, heated air inlets or opening windows.

5.3.5 Combustion air inlet

5.3.5.1 The air for the combustion chamber of the heater must not be drawn from the passenger compartment of the vehicle.

5.3.5.2 The air inlet must be so positioned or guarded that blocking by rubbish or luggage is unlikely.

(...)

5.3.8 Automatic control of the heating system

5.3.8.1 The heating system must be switched off automatically and the supply of fuel must be stopped within five seconds when the vehicle's engine stops running. If a manual device is already activated, the heating system can stay in operation.

... "

3 Overview of heater

3.1 Intended use

The heater is used in combination with the vehicle's own heating system for:

- Heating the passenger compartment
- Pre-heating

The heater may only be installed and operated in vehicles of the following categories: M2, M3, N2, N3, O1, O2, O3, O4

Any other use is not permissible.

The heater variants Thermo plus 230 / 300 / 350 RAIL are designed for installation in rail vehicles and meet the necessary requirements. See Expert Opinion VG97456T for an assessment of rail suitability.

Particular attention must be paid to the installation conditions in section 7. The customer is responsible for adhering to the weight limits if grouping is used in the particular application.

The heater operates independently of the vehicle engine and is connected to:

- Cooling circuit of the vehicle or a separate heating circuit
- Fuel system of the vehicle or a separate fuel system (e.g., additional tank)
- Electric power supply

WARNING

Danger to life from unintended use!

The heater is not approved for operation in vehicles used to transport hazardous goods as per Annex 9 of UN-ECE Regulation R122.

- ▶ Only operate the heater in suitable vehicles.

3.2 Models

The following 24-V heaters for diesel fuel are available:

Thermo plus	Nominal heat output	
	In kW	In kcal/h
160	16	13,800
230	23	20,000
300	30	26,000
350	35	30,000

Tab. 2: Nominal heat output of Thermo plus heaters

3.3 Function

For a general functional description of the heater, see the workshop manual.

3.4 Description and dimensions

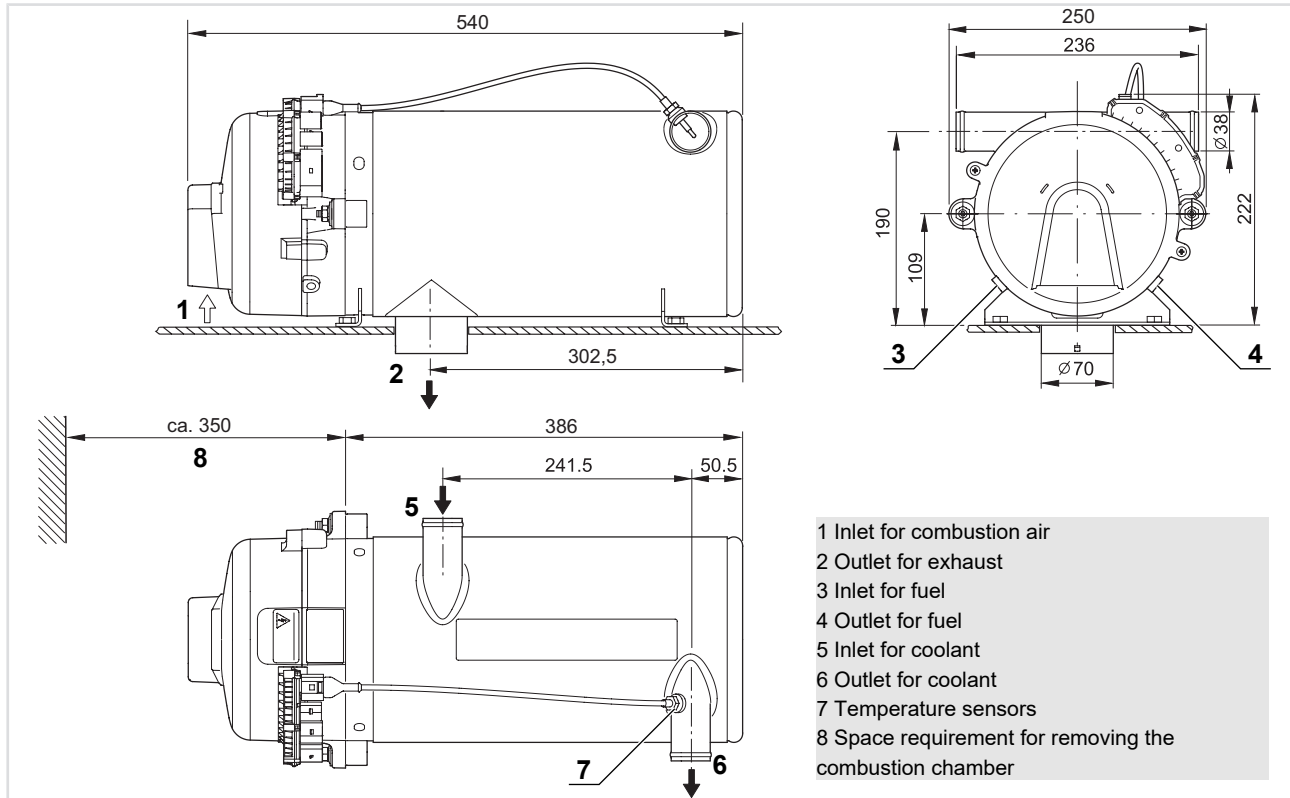

Fig. 1: Thermo plus 300 dimensions

3.5 Type label

Every heater has two type labels. The type label of the heater is located on the housing. The type label of the control unit is located under the hood of the control unit.

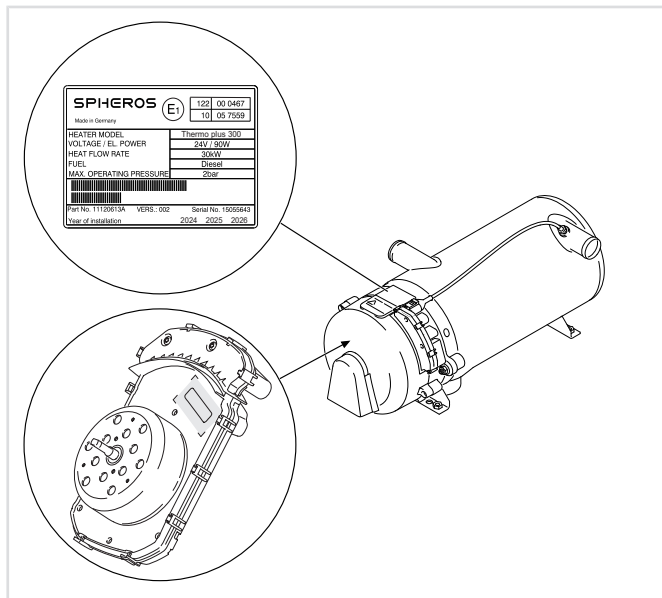

Fig. 2: Example of placement of type labels on Thermo plus

NOTICE

Mark the year in which the heater was first operated on the type label. Remove the years that do not apply.

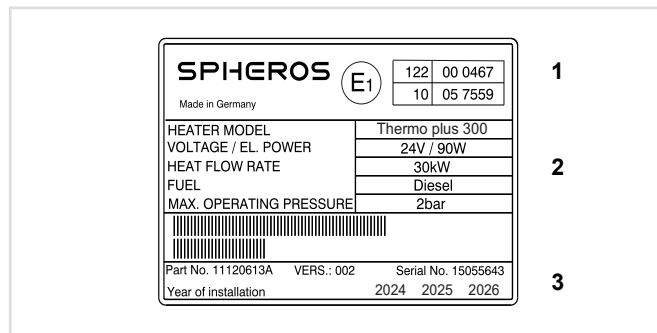

Fig. 3: Example of type label on Thermo plus heater

- 1 Data on manufacturer, for authorization and approval
- 2 Technical data (see also 13 *Technical data*, Page 34)
- 3 Identification number, version, serial number and year of initial operation



Fig. 4: Example of type label on Thermo plus control unit

- 1 Data on manufacturer
- 2 Designation and article number

4 Heater installation

The heater must be protected against outer influences at the installation location. Outer influences (e.g., roadway dirt and splash water) may impair the proper functioning of the heater.

NOTICE

The heater has been designed, tested and approved in accordance with bus-specific and special rail-specific requirements. See 3.1 *Intended use*, Page 9.

For installation, see also the following chapters:

- 2.2 *Legal provisions for installation*, Page 7
- 6 *Connecting the cooling system*, Page 17
- 7 *Fuel system*, Page 18
- 8 *Combustion air supply*, Page 20

4.1 Installation location

Install the heater as low as possible in the vehicle. This improves the independent venting of the cooling circuit or separate heating circuit.

Sufficient space must be available for maintenance (e.g., to remove the combustion chamber). See the figure showing the space requirements in 3.4 *Description and dimensions*, Page 10.

WARNING

Danger to life from fires!

Material located close to the outlet for exhaust may ignite due to the high exhaust gas temperatures. Fires may cause life-threatening injuries.

- ▶ When installing the heater, ensure that there is sufficient clearance to other components.

ATTENTION

The installation space is not a storage space.

- ▶ Keep the installation space clear and clean.

NOTICE

Ensure that the type label is legible when the heater is installed.

4.1.1 Installation space

Note the following when installing the heater:

- Draw in combustion air from the outside.
- Direct the exhaust gas to the outside (e.g., through an exhaust pipe).
- Protect the installation space against splash water.
- Water that penetrates into the interior and condensate must be able to flow out of the installation space on its own.

If the heater is located in a closed installation space, a ventilation opening is required. Observe the following cross sections:

Thermo plus	Ventilation opening		
160 230 300	Min. cross section	cm ²	30
350	Min. cross section	cm ²	40

Tab. 3: Ventilation opening cross sections when the installation space is closed

Check the effectiveness of the ventilation. See 11 *Initial operation*, Page 31. For information on adjusting the CO² value, see the workshop manual.

4.2 Installation position

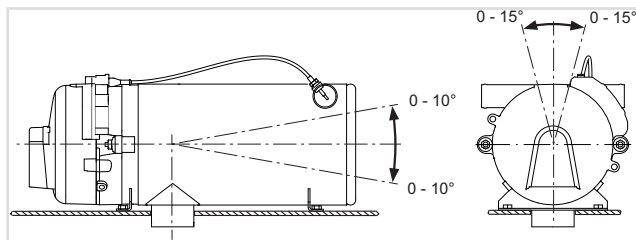

Fig. 5: Thermo plus installation position

NOTICE

Install the heater in a horizontal position. Vertical installation is not permissible.

The heater has four mounting points on the bottom for mounting at the installation location. Select one of the following fastening variants:

- A: Four M8 screws via weld nuts in the four drilled holes (1)
- B: Four M8 screws plus hexagon nuts and 8.4 washers in the four drilled holes (2)

NOTICE

Select the length of the M8 screws so that there is no contact with the heat exchanger.

The heater has an outlet for exhaust at the bottom. Pass the port to the outside via a round opening (see hole pattern). Use an application on the exhaust gas side. See 9 Exhaust pipe, Page 22.

For the application on the exhaust gas side (e.g., exhaust pipe), introduce a larger hole (3) and four drilled holes (4) at the installation location. Use the following screws for the drilled holes (4):

- M4 screws = drilled hole \varnothing 4.5 mm
- B 3.9 tapping screws = drilled hole \varnothing 2.9 mm

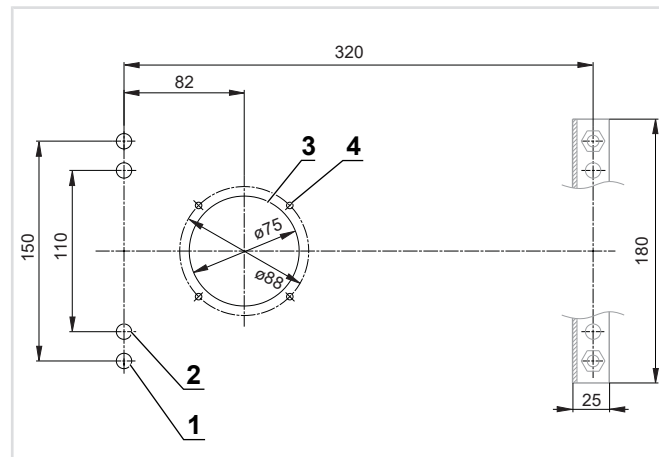

Fig. 6: Thermo plus hole pattern

- | | |
|------------------------------|--|
| 1 Drilled hole for M8 screws | 2 Drilled hole for M8 screws |
| 3 Hole for exhaust pipe | 4 Drilled hole for M4 screws or B 3.9 tapping screws |

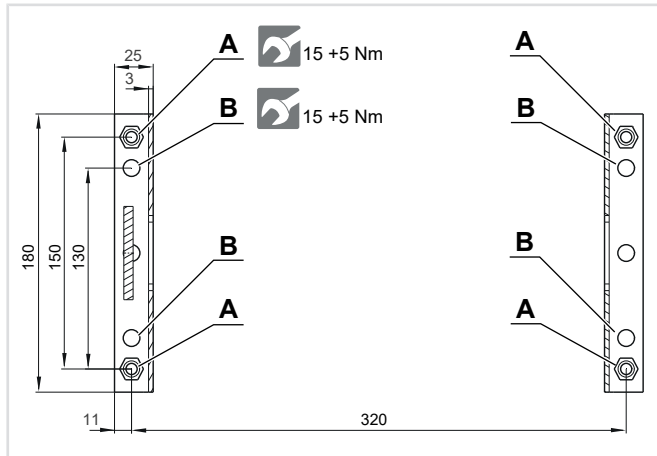

Fig. 7: Torques for fastening Thermo plus heater

- A Fastening variant: Four M8 screws via weld nuts
- B Fastening variant: Four M8 screws plus M8 hexagon nuts and 8.4 washers

4.3 Installation example

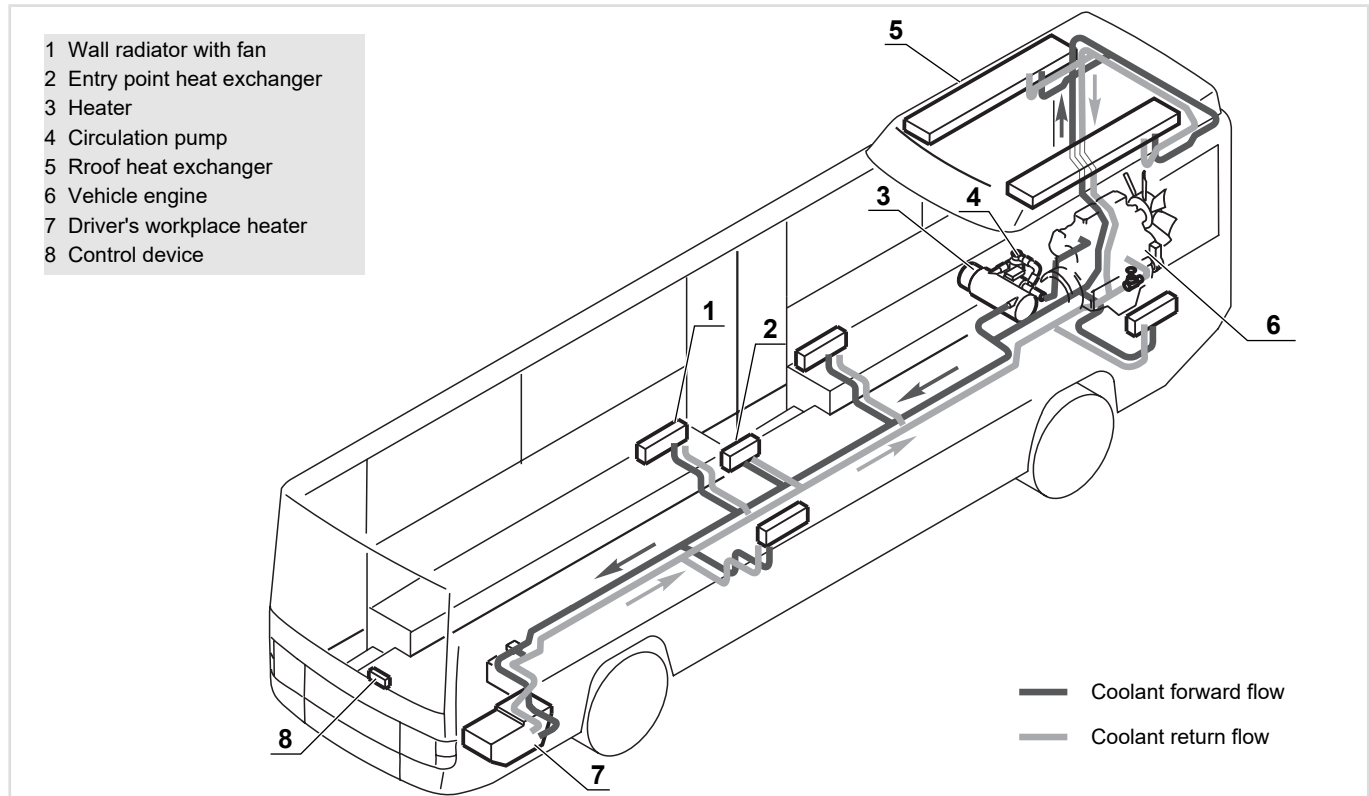

Fig. 8: Installation example for heater

5 Circulation pump installation

The circulation pump must be protected against external influences at the installation location. Outer influences (e.g., roadway dirt and splash water) may impair the proper functioning of the circulation pump.

5.1 Models

The following 24-V circulation pumps are available:

- Aquavent 5000 (U4814)
- Aquavent 5000S (U4854)
- Aquavent 6000C (U4855)
- Aquavent 6000SC (U4856)
- SPump

5.2 Overview of documents

For information on the installation, operation and maintenance of the circulation pump, use the following documents:

- Installation instructions Aquavent pumps
- Installation instructions SPump S120
- Installation instructions SPump 260 and 500

The current versions of these documents are listed in the Download Center at www.spheros.com.



5.3 Installation location

Connect the circulation pump to:

- The cooling system of the vehicle or the separate heating circuit
- The vehicle electrical system

Position the circulation pump in front of the heater inlet for coolant. Install the circulation pump as low as possible in the vehicle. This improves the independent venting of the cooling circuit or separate heating circuit.

NOTICE

Spheros circulation pumps are not self-priming.

5.4 Installation position

Observe the installation positions when installing. See *Attachment A, Page 40*.

NOTICE

The circulation pump has an inlet and outlet for coolant. Ensure that the lines are laid without tension.

6 Connecting the cooling system

Connect the heater to the cooling circuit of the vehicle or to the separate heating circuit. Note the following values for the circuit:

- Min. quantity of coolant in circuit
- Min. flow rate of coolant

See *Tab. 19: Thermo plus technical data, Page 35.*

NOTICE

Coolant consists of water and antifreeze agent. The proportion of antifreeze agent must be at least 30%. Only operate Spheros heaters with an approved antifreeze agent.

The antifreeze agents approved by Spheros are listed in the Download Center at www.spheros.com.

ATTENTION

Excessive pressure in the cooling circuit of the vehicle or in the separate heating circuit leads to damage.

- ▶ Use pressure control valves with an opening pressure of at least 0.4 bar and at most 2.0 bar.

6.1 Lines for coolant

The hoses for coolant must at least comply with DIN 73411.

To ensure fault-free venting of the heater, lay hoses and pipes so they are rising.

Hoses must be secured with hose clamps to prevent them from slipping.

NOTICE

Retighten the hose clamps after 2 h in heating mode or 100 km of driving. Note the torques of the hose clamps used. See the workshop manual.

6.2 Filling and venting the circuit

Before initial operation, completely fill the cooling circuit of the vehicle or the separate heating circuit with coolant and vent the circuit after testing.

ATTENTION

A dry run can cause the circulation pump to fail.

- ▶ Do not vent the circuit with the circulation pump.

ATTENTION

Poor venting of the circuit causes the heater to overheat in heating mode. The heater switches off.

- ▶ Vent the circuit before initial operation.
- ▶ Vent the circuit after renewing the coolant.

7 Fuel system

The fuel is taken from the vehicle fuel tank or from a separate fuel tank. Ventilation must be provided at the container.

ATTENTION

Dripping or evaporating fuel can ignite on contact with hot parts or electrical components.

- ▶ Ensure that fuel does not collect under the burner.
- ▶ Unintentionally dripping fuel must not come into contact with the hot exhaust gas outlet.

7.1 Lines for fuel

Use the hoses and pipes supplied by Spheros. The fuel hoses must at least comply with DIN 73379.

NOTICE

If hoses and pipes designed for overpressure are used, air may enter into the circuit on account of the actually applied vacuum. Only use hoses and pipes that are suitable for the application (temperature) and the type of fuel used (biodiesel).

To ensure fault-free venting of the heater, lay hoses and pipes so they are rising.

NOTICE

The suction line and the fuel filter must be prefilled before the first initial operation. Ensure that the return flow into the tank ends below the fluid level.

Secure hoses and pipes at distances of no more than 25 cm apart with fastening clamps.

Secure connections of hoses and pipes with hose clamps if no mechanical screw fittings are used.

ATTENTION

The lines and filters for fuel may be damaged by external mechanical influences.

- ▶ Protect the lines and filters against being bent, crushed, twisted and chafed.
- ▶ Protect the lines and filters against being hit by stones.
- ▶ Protect the lines and filters against high temperatures.

ATTENTION

Operation with a closed return flow causes damage to the fuel pump and lines. This can cause fuel to exit and ignite.

- ▶ Ensure that the return flow is open during operation.

7.1.1 Permissible fuel line dimensions

Line dimensions **		
Inside diameter (forward and return flows)	mm	6
Max. perm. line length (forward flow) *	m	15
Max. perm. line length (return flow) *	m	15
* At max. perm. suction height: 2 m and max. perm. static pressure: 300 mbar rel.		
** Min. bending radius 70 mm		

Tab. 4: Fuel line dimensions

NOTICE

Deviations from the permissible dimensions must be approved by Spheros.

7.2 Prefilling and venting the fuel system

Fill the following parts of the fuel system all the way to the heater with fuel and then vent the system:

- Suction line upstream of fuel filter
- Fuel filter
- Suction line downstream of fuel filter

NOTICE

Use of a separate venting device is recommended.

During vehicle operation, the fuel supply must be reliable and free of bubbles.

ATTENTION

A dry run can cause the fuel pump to fail.

- ▶ Do not fill the fuel system using the fuel pump.

ATTENTION

Poor venting of the fuel system causes flame arrest, fault shutdown and possibly locking of the heater during operation.

- ▶ Fill the system before initial operation.
- ▶ Fill the system after exchanging components (e.g., filters)

7.3 Fuel filter

Install the filters supplied by Spheros.

NOTICE

Only use filters approved by Spheros.

Be sure to install the filter in the correct flow direction.

ATTENTION

As the number of operating hours increases, flow resistance in the fuel supply may increase due to deposits. Filters may become clogged. The heater may malfunction.

- ▶ Change the filter or filter insert before every heating season.

7.4 Permissible vacuum in fuel system (at the heater inlet for fuel)

To ensure proper functioning of the heater, ensure that the vacuum in the fuel system is not too large.

Suction line vacuum (forward flow)		
Max. perm. vacuum	mbar	-350

Tab. 5: Vacuum of fuel suction line

NOTICE

Deviating applications at the air intake and exhaust must be approved by Spheros.

8 Combustion air supply

For installation of the line for combustion air, see also the following chapters:

- 2.2 *Legal provisions for installation, Page 7*
- 4.1.1 *Installation space, Page 12*

8.1 Line for combustion air

NOTICE

Only use lines and components approved by Spheros. Air filter systems in the line for combustion air are impermissible.

Bending angle of lines		
Max. perm. sum of bending angles for all lines (combustion air and exhaust gas)	De-grees	270

Tab. 6: Bending angle of lines

Lay the line for combustion air in a descending manner to prevent condensate from collecting. If this is not possible, introduce a \varnothing 4-mm drain hole at the lowest point.

ATTENTION

An incorrectly installed line for combustion air can lead to property damage.

- ▶ Protect the intake opening against the ingress of dirt or snow.
- ▶ Position the opening opposite to the direction of travel.
- ▶ Do not draw in splash water via the opening.

Thermo plus	Line for combustion air ****			Exhaust pipe ***	
	Altitude of use * in m	Inside \varnothing in mm	Max. length in m	Inside \varnothing in mm	Max. length in m
160 230	Up to 1,500	55	5.0 **	70	5.0 **
	Above 1,500	55	5.0	70	5.0
300	Up to 1,500	55	5.0 **	70	5.0 **
	Above 1,500	55	3.0	70	3.0
350	Up to 1,500	55	5.0 **	70	5.0 **
	Above 1,500	55	1.5	70	1.0

* When operated primarily above this elevation, the CO₂ value of the heater must be readjusted according to the specified technical data.
 ** The total length for all lines (combustion air and exhaust gas) must not exceed 5.0 m.
 *** Min. bending radius 140 mm
 **** Min. bending radius standard 44 mm or min. bending radius rail 85 mm (line as per DIN EN 45545)

Tab. 7: Dimensions of the lines for combustion air and exhaust gas

NOTICE

Deviations from the permissible dimensions must be approved by Spheros.

If the heater is located in a closed installation location, a ventilation opening is required. Observe the following cross sections:

Thermo plus	Ventilation opening		
160 230 300	Min. cross section	cm ²	30
350	Min. cross section	cm ²	40

Tab. 8: Ventilation opening cross sections when the installation space is closed

9 Exhaust pipe

For installation of the exhaust pipe, see also the following chapters:

- 2.2 *Legal provisions for installation, Page 7*
- 4.1.1 *Installation space, Page 12*

ATTENTION

Exhaust gas temperatures of up to 400 °C (depending on the heating output class) can cause fires.

- ▶ Maintain a sufficient distance to heat-sensitive or combustible materials. If this is not possible, insulate the exhaust pipe.
- ▶ Do not draw in the exhaust gas as combustion air.
- ▶ The opening of the line must not face the direction of travel.
- ▶ The exhaust pipe must not become clogged with dirt or snow.
- ▶ An outlet for exhaust gas under the vehicle floor with the blow-out facing vertically downward is only permissible if an exhaust gas deflection is present. For information on the exhaust gas deflection, see the accessories catalog.

9.1 Exhaust pipe

Fasten the exhaust pipe at distances of no more than 50 cm apart with clamps. The following pipes are approved for use:

- Rigid pipes made of non-alloyed or alloyed steel with a wall thickness ≥ 1.0 mm
- Flexible pipes of alloyed steel

Secure the exhaust pipe on the heater, for example with a clamp.

Bending angle of lines		
Max. perm. sum of bending angles for all lines (combustion air and exhaust gas)	De-grees	270

Tab. 9: Bending angle of lines

Lay the exhaust pipe in a descending manner to prevent condensate from collecting. If this is not possible, introduce a \varnothing 4-mm drain hole.

Thermo plus	Altitude of use * in m	Line for combustion air ****		Exhaust pipe ***	
		Inside \varnothing in mm	Max. length in m	Inside \varnothing in mm	Max. length in m
160 230	Up to 1,500	55	5.0 **	70	5.0 **
	Above 1,500	55	5.0	70	5.0
300	Up to 1,500	55	5.0 **	70	5.0 **
	Above 1,500	55	3.0	70	3.0
350	Up to 1,500	55	5.0 **	70	5.0 **
	Above 1,500	55	1.5	70	1.0

Thermo plus	Line for combustion air ****	Exhaust pipe ***
<p>* When operated primarily above this elevation, the CO₂ value of the heater must be readjusted according to the specified technical data.</p> <p>** The total length for all lines (combustion air and exhaust gas) must not exceed 5.0 m.</p> <p>*** Min. bending radius 140 mm</p> <p>**** Min. bending radius standard 44 mm or min. bending radius rail 85 mm (line as per DIN EN 45545)</p>		

Tab. 10: Dimensions of the lines for combustion air and exhaust gas

NOTICE

Deviations from the permissible dimensions must be approved by Spheros.

WARNING

Danger of injury due to hot pipe!

The hot exhaust pipe causes injuries on contact.

► Protect the exhaust pipe against contact.

10 Electrics and electronics

NOTICE

The heater is electrically connected via the exterior plug connections. Do not open the heater.

ATTENTION

The electrical lines may be damaged by external mechanical influences.

- ▶ Protect all lines against being pinched and bent.
- ▶ Protect the line insulation against being chafed through.
- ▶ Protect all lines against heat.

ATTENTION

Establish the electrical plug connection to the heater using the original plugs, contacts and single wire seals.

- ▶ Protect the electrical plug connections when not in use.
- ▶ Close all plug connections that are not in use with blind plugs.
- ▶ Close all sockets not in use with blind plugs.

10.1 Prerequisites for electrical connections

10.1.1 Ripple voltage

The ripple voltage must not exceed 2 V_{pp} (V_{pp}: peak - peak). If the voltage is exceeded, the electrical and electronic components can be expected to have a reduced service life.

10.1.2 Load dump protection

For full load dump protection, the heater may only be used in vehicles with a central voltage limitation.

10.1.3 Power supply

The heater is only intended for operation with a car battery. This enables higher starting currents to be provided, among other things.

A power supply via an external current supply (preconditioning in depot) is permissible.

10.2 Electrical cabling

The heater must be electrically connected as per the circuit diagram:

- *Circuit diagrams, Page 29*
- *Circuit diagrams, Page 28*

Connect the heater (negative pole and positive pole of the control unit) directly to the power supply without a disconnect switch. This ensures that the heater can be switched off correctly along with run-on operation.

10.2.1 Cable cross section of signal line

Plug "C", pos. C5 to C10 is used for the signal lines. For more information on plug "C", see *Connector pin assignment, Page 27*.

The following table contains the specified cable cross sections for the respective line lengths. The generally applicable electrotechnical rules apply.

Line length < 7.5 m	Line length 7.5 to 15 m
0.75 mm ²	1.5 mm ² *
* At contact max. 1 mm ²	

Tab. 11: Cable cross section of signal line(s)

10.2.2 Cross section of supply line

The following plugs are used for the supply line(s):

- Plug "C", pos. C1 to C4
- Plug "P", pos. P1 to P2

For more information on plugs "C" and "P", see *Connector pin assignment, Page 27*.

Ensure that the voltage drop (supply and return lines combined) is less than 1 V.

The following table contains the specified cable cross sections for the respective line lengths. The generally applicable electrotechnical rules apply.

Line length < 7.5 m	Line length 7.5 to 15 m
2.5 mm ²	4.0 mm ² *
* At contact max. 2.5 mm ²	

Tab. 12: Cross section of supply line(s)

10.3 Connecting the controls

The heater can be switched on and off using the following controls from Sferos, among other things:

- Switch
- Preselection timer

For more information on switching the controls, see *10.8 Circuit diagrams, Page 27*.

The unit can also be controlled via the vehicle climate control. The climate control has its own controls.

10.4 Connecting the heater

The control unit is located under the hood of the burner. The following plugs are accessible from the outside:

- Plug "C": power supply and control signal
- Plug "P": circulation pump
- Plug "T": temperature sensor
- Plug "G": diagnostic interface

For more information on the plugs, see *10.7 Plug, Page 26*.

10.5 Activating economy mode

Establish the "Eco" mode according to the circuit diagram. See *10.8 Circuit diagrams, Page 27*.

For information on the economy mode, see the workshop manual.

10.6 Connecting terminal "T. 61"

Connect terminal "T.61" according to the circuit diagram. See *10.8 Circuit diagrams, Page 27*.

The following table contains the possible heating modes with the switching thresholds:

Thermo plus	Parking heating mode		Economy mode (+24 V at C8)		Auxiliary heating mode (+24 V at C7)	
	On*	Off* (RP**)	On	Off (RP)	On	Off (RP)
160	67	77	55	70	72	82
230						
300						
350						

Thermo plus	Parking heating mode		Economy mode (+24 V at C8)		Auxiliary heating mode (+24 V at C7)	
230 Rail	45	60	25	40	70	85
300 Rail						
350 Rail						
* On/off: lower/upper switching threshold in °C ** RP: control break						

Tab. 13: Switching thresholds for various coolant temperatures (standard data set)

NOTICE

The auxiliary heating mode has priority over the economy mode.

10.7 Plug

To connect a circulation pump to the heater, use a Spheros cable harness.

ATTENTION

To prevent corrosion, the connector contacts are coated with a conductive protective coat. The protective coat is destroyed if the plug is connected and disconnected too frequently. This will result in poor contact.

- Avoid connecting and disconnecting the plug unnecessarily.

NOTICE

Only use original plugs approved by Spheros.

10.7.1 Plug "C": power supply and control signal

Connect all 4 connections to a cable cross section of 2.5 mm².

For the required mating connectors, see the spare parts list.

10.7.2 Plug "P": circulation pump

A cable cross section of 2.5 mm² is recommended.

For the required mating connectors or blind plugs, see the spare parts list.

10.7.3 Plug "G": diagnostic interface

For the required blind plugs, see the spare parts list.

10.7.4 Connector pin assignment

Plug	Description	
C	Connection to vehicle	
C1	T.30 UP, DVW (+)	
C2	T.31 UP, DVW (-)	
C3	T.30 HG (+)	
C4	T.31 HG (-)	
C5	HS	
C6	UPFA	
C7	T.61 (D+)	
C8	Eco	
C9	BA (+)	
C10	FA (-)	
T	Temperature sensors	
T1	PT2000 (+)	
T2	PT500 (+)	
T3	Ground	

Plug	Description	
P	Circulation pump	
P1	UP (+)	
P2	UP (-)	
G	Diagnosis- Thermo Test (DTT)	
G1	(+)	
G2	(-)	
G3	S-bus/K-Line	
G4	-	

Tab. 14: Connector pin assignment

For an explanation of the abbreviations, see 10.8.1 Abbreviations used in the circuit diagram and connector pin assignment, Page 30.

10.8 Circuit diagrams

The following circuit diagrams are available:

- *Circuit diagrams, Page 28*
- *Circuit diagrams, Page 29*

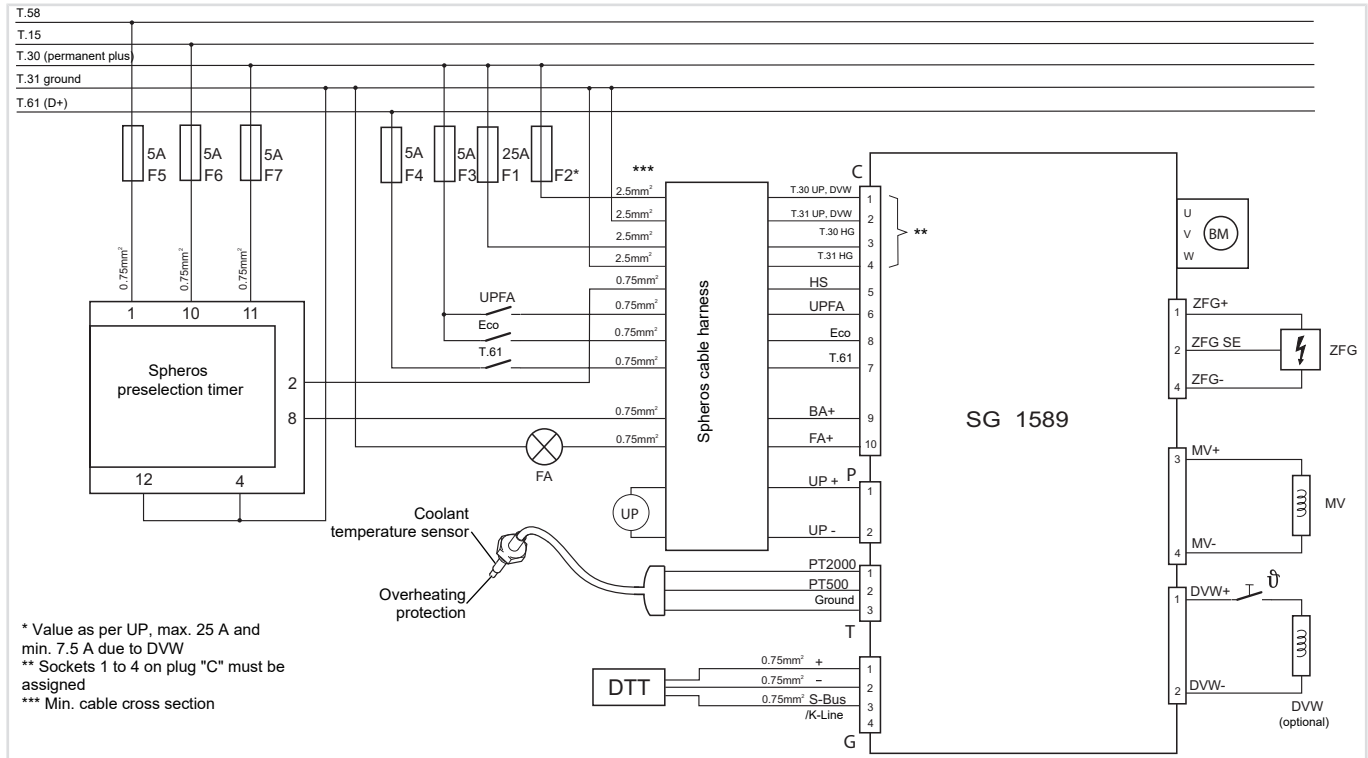

Fig. 9: Circuit diagram for Thermo plus with preselection timer
 For an explanation of the abbreviations, see 10.8.1 Abbreviations used in the circuit diagram and connector pin assignment, Page 30.

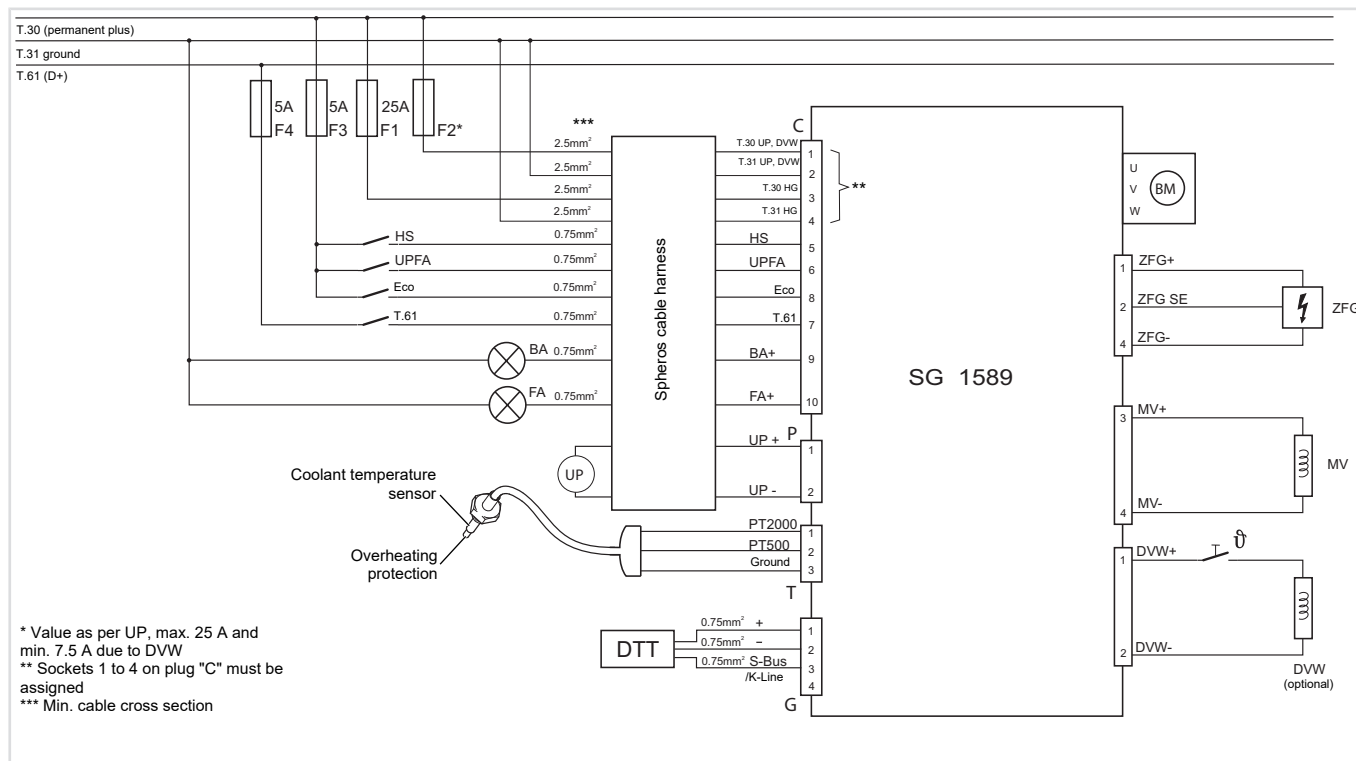

Fig. 10: Circuit diagram for Thermo plus with switch
 For an explanation of the abbreviations, see 10.8.1 Abbreviations used in the circuit diagram and connector pin assignment, Page 30.

10.8.1 Abbreviations used in the circuit diagram and connector pin assignment

Abbreviation	Description
BA	Operation indicator 3 W (max. 5 W)
BM	Burner motor (in heater)
DTT	Diagnostic Thermo Test
DVW	Nozzle block preheating (in heater)
FA	Flame indicator 3 W (max. 5 W)
F1	Flat type fuse 25 A as per DIN 72581 Part 3 or ISO 8820-3
F2 *	Flat type fuse 25 A as per DIN 72581 Part 3 or ISO 8820-3
F3 to F7	Flat type fuse 5 A as per DIN 72581 Part 3 or ISO 8820-3
HG	Heater
HS	Main switch
MV	Solenoid valve (in heater)
PT500	Overheating protection
PT2000	Temperature sensor
Eco	Economy mode
UP	Circulation pump
UPFA	External control of circulation pump
ZFG	Ignition spark generator (in heater)

Abbreviation	Description
	* If smaller cable cross sections are connected to the circulation pump, the fuses must be adapted accordingly.

Tab. 15: Abbreviations used in the circuit diagram and connector pin assignment

NOTICE

The flat type fuses are designed for ambient temperatures of max. 60 °C.

11 Initial operation

NOTICE

Before initial operation of the heater, read the instructions on installation, operation and maintenance.

For initial operation, also note the following chapter:

- 1.4 Overview of documents, Page 4

11.1 Initial operation of the heater

Conditions:

The heater has been installed. See 4 Heater installation, Page 12.

The heater has been connected. See 10 Electrics and electronics, Page 24.

The circuit between the vehicle battery and the heater is disconnected (e.g., the fuse is not in place).

The fuel system is prefilled and vented. See 7.2 Prefilling and venting the fuel system, Page 19.

The cooling circuit of the vehicle or the separate heating circuit is filled. See 6.2 Filling and venting the circuit, Page 17.

1. Connect the circuit between the vehicle battery and the heater (e.g., insert the fuse).
2. Perform a test run. Check all existing coolant and fuel connections for leak tightness and firm seating. Check that the permissible values are complied with:
 - CO₂ in exhaust gas at nominal voltage

- Perm. ambient temperature during operation
 - Max. perm. combustion air temperature
- See Tab. 19: Thermo plus technical data, Page 35.

- ✓ If a malfunction occurs during a test run, troubleshoot the problem. See the workshop manual.
- ✓ If the permissible values are complied with, continue with the following step.

3. Vent the cooling circuit of the vehicle or the separate heating circuit. See 6.2 Filling and venting the circuit, Page 17.

- ✓ The heater is ready for operation.

WARNING

Fire and explosion hazard due to fuels!

Fuels at gas stations and tank systems may ignite due to the high temperatures of the exhaust gases.

- ▶ Attach the label with the notice "Equipped with a Spheros parking heater. Switch off the parking heater before refueling!" on or close to the tank filler neck.
- ▶ Always switch off the vehicle engine and the heater at gas stations and tank systems.

11.2 Elevation and CO₂ setting

The heater is set at the factory for use at an elevation of up to 1,500 m. See the following table.

Elevation (above NHN) in m	Heating mode	Adjustment of CO ₂ setting
Up to 1,500	Unrestricted	Not required
Up to 2,000	Unrestricted for short periods at high elevations (crossing of a mountain pass, rest times)	Not required
Permanently above 1,500	Restricted	Required

Tab. 16: Elevation and CO₂ setting

When using applications on the intake or exhaust side, adjust the CO₂ value. For information on adjusting the CO₂ value, see the workshop manual.

11.3 Malfunctions and faults

When a fault occurs, the heater is switched off by a fault shut-down feature and goes into fault lockout or heater lock mode.

If equipped with a preselection timer, this is indicated by a malfunction symbol in the display. Also, a blink code may be output by the operating indicator light.

For information on troubleshooting and fault elimination, see the workshop manual.

12 Maintenance

For information on the periodic maintenance of the heater, see the workshop manual and maintenance plan.

13 Technical data

Unless limit values are specified, tolerances of $\pm 10\%$ (at $+20\text{ °C}$ ambient temperature and nominal voltage) apply to the technical data of heaters.

13.1 Fuel

The following table lists the fuels approved by Spheros and their requirements.

Fuel	Requirements as per	Remarks
Summer diesel	DIN EN 590	<ul style="list-style-type: none"> 0 °C to -18 °C: Use commercially-available winter diesel Below -18 °C: Use diesel for arctic and harsh winter climates
Winter diesel	DIN EN 590	
Use diesel for arctic and harsh winter climates	DIN EN 590	
Biodiesel (FAME)	DIN EN 14214	<ul style="list-style-type: none"> See the Technical Information (TI) for fuels *
Paraffinic diesel fuel from synthesis or hydrogenation process (HVO)	DIN EN 15940	<ul style="list-style-type: none"> Selected fuels only See the Technical Information (TI) for fuels *

Fuel	Requirements as per	Remarks
Extra-light heating oil (EL)	DIN 51603	<ul style="list-style-type: none"> 0 °C to -10 °C: Use nozzle block preheating and heating element fuel filter Below -10 °C: Operation not possible
<p>* The current versions are listed in the Download Center at www.spheros.com.</p>		

Tab. 17: Fuels

ATTENTION

Note the application areas of fuels. Take additional measures (installation of a nozzle block preheating, installation of a heating element fuel filter) as needed.

13.2 Heating element fuel filter (optional)

Heating element fuel filter		
Power consumption at nominal voltage	W	240
Nominal voltage	V	24
Switch-on point	°C	0.5 ± 2.5
Switch-off point	°C	5.5 ± 2.5

Tab. 18: Technical data of the heating element fuel filter

13.3 Heater

Thermo plus heater		160	230	300	350
Type approval number	E1 122R 00	0580	0466	0467	0468
Type		High pressure atomizer			
Heat output at ambient temperature of 20 °C	kW (kcal/h)	16 (13,800)	23 (20,000)	30 (26,000)	35 (30,000)
Fuel		Diesel/heating oil EL			
Fuel consumption	kg/h	1.6	2.5	3.0	3.6
Nominal voltage	V	24			
Permitted operating voltage	V	20.5 to 30			
Power consumption at nominal voltage 24 V *	W	65	60	90	120
Max. perm. combustion air temperature at ambient temperature < 85 °C	°C	85			
Max. perm. combustion air temperature at ambient temperature > 85 °C	°C	60			
Perm. ambient temperature during operation	°C	-40 to +100			
Perm. storage temperature	°C	-40 to +110			
Max. perm. operating overpressure	bar	2.0			
Heat exchanger fill quantity	l	1.8			
Min. flow rate of coolant **	l/h	1400	1900	2400	2700
Min. quantity of coolant in circuit (in which the heater is integrated) without attached parts	l	25			
CO ₂ in exhaust gas at nominal voltage	Vol.-%	9.5 + 1.0	9.0 + 1.5	9.5 + 1.5	9.5 + 1.5
Heater dimensions (length/width/height)	mm	540/250/222			
Weight without attached parts	kg	16.5	16.8		

Thermo plus heater	160	230	300	350
* Without circulation pump				
** At coolant temperatures > 50 °C. A lower flow rate of coolant is permissible at temperatures < 50 °C provided that vapor bubbles due to overheating in the cooling system can be reliably ruled out.				

Tab. 19: Thermo plus technical data

13.4 Circulation pump

Circulation pump		Aquavent 5000 (U4814)	Aquavent 5000S (U4854)	Aquavent 6000C (U4855)	Aquavent 6000SC (U4856)	SPump 260
Volume flow	l/h	5000 (0.2 bar *)	5000 (0.2 bar *)	6000 (0.4 bar *)	6000 (0.4 bar *)	6000 (0.5 bar *)
Nominal voltage	V	24	24	24	24	24
Permitted operating voltage	V	20 to 28	20 to 28	20 to 28	20 to 28	16.5 to 32
Power consumption at nominal voltage	W	104	104	210	210	260
* Back pressure						

Tab. 20: Circulation pump technical data

For more information and technical data on circulation pumps, see 5.2 *Overview of documents, Page 16*.

NOTICE

If the circulation pump is controlled by the heater, the Spheros cable harness must be used.

14 Disposal

For general information on recycling, contact your local recycling companies.

14.1 Old devices and components

Dispose of the old device and the components properly. Proceed as follows:

1. Disassemble the old device and the components. See the workshop manual.
2. Separate the disassembled parts by type of material.
3. Dispose of the various materials properly.

NOTICE

The recycling conditions of the individual materials apply.

The following materials are contained in Spheros heaters:

- Steel
- Nonferrous metal
- Aluminum
- Plastic
- Electrical and electronic waste (motor, control unit, cable harness and sensor)

14.2 Packaging

Dispose of the packaging properly.

NOTICE

The recycling conditions of the individual materials apply.

Tab. 1	Thermo plus abbreviations used	5	Tab. 19	Thermo plus technical data	35
Tab. 2	Nominal heat output of Thermo plus heaters ..	9	Tab. 20	Circulation pump technical data	36
Tab. 3	Ventilation opening cross sections when the installation space is closed	12			
Tab. 4	Fuel line dimensions	18			
Tab. 5	Vacuum of fuel suction line	19			
Tab. 6	Bending angle of lines	20			
Tab. 7	Dimensions of the lines for combustion air and exhaust gas	20			
Tab. 8	Ventilation opening cross sections when the installation space is closed	21			
Tab. 9	Bending angle of lines	22			
Tab. 10	Dimensions of the lines for combustion air and exhaust gas	22			
Tab. 11	Cable cross section of signal line(s)	24			
Tab. 12	Cross section of supply line(s)	25			
Tab. 13	Switching thresholds for various coolant tem- peratures (standard data set)	25			
Tab. 14	Connector pin assignment	27			
Tab. 15	Abbreviations used in the circuit diagram and connector pin assignment	30			
Tab. 16	Elevation and CO2 setting	32			
Tab. 17	Fuels	34			
Tab. 18	Technical data of the heating element fuel fil- ter	34			

Fig. 1	Thermo plus 300 dimensions	10
Fig. 2	Example of placement of type labels on Thermo plus	11
Fig. 3	Example of type label on Thermo plus heater .	11
Fig. 4	Example of type label on Thermo plus control unit.....	11
Fig. 5	Thermo plus installation position	13
Fig. 6	Thermo plus hole pattern	13
Fig. 7	Torques for fastening Thermo plus heater	14
Fig. 8	Installation example for heater	15
Fig. 9	Circuit diagram for Thermo plus with preselection timer.....	28
Fig. 10	Circuit diagram for Thermo plus with switch....	29
Fig. 11	Installation position U4814	40
Fig. 12	Installation position U4854	40
Fig. 13	Installation position U4855	41
Fig. 14	Installation position U4856	41
Fig. 15	Installation position SPump 260-500.....	42
Fig. 16	Hole pattern of circulation pump mounting points.....	42

Attachment A

A.1 Circulation pump installation positions

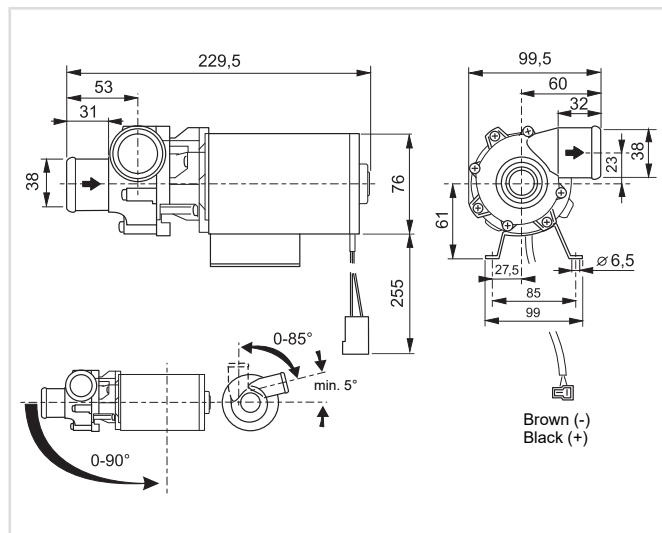

Fig. 11: Installation position U4814

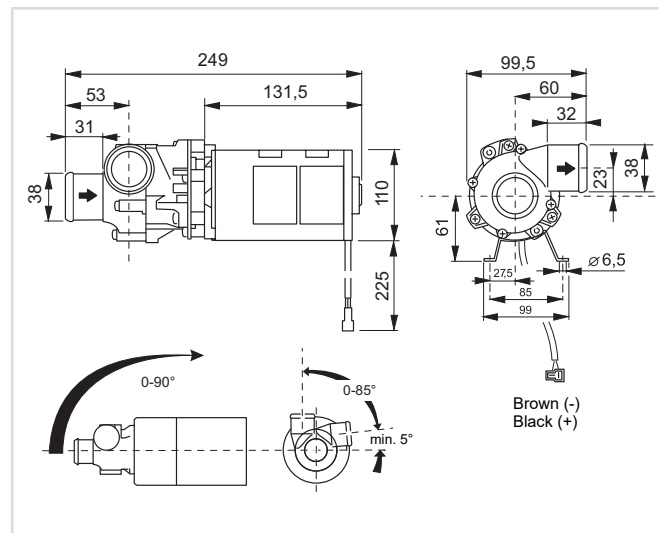

Fig. 12: Installation position U4854

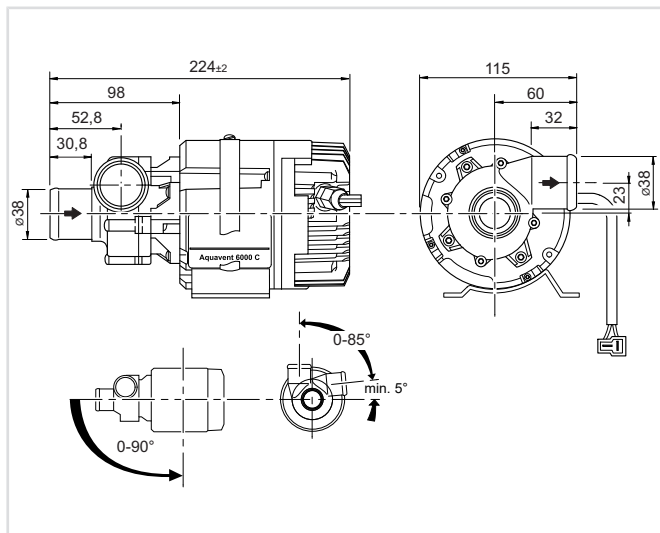

Fig. 13: Installation position U4855

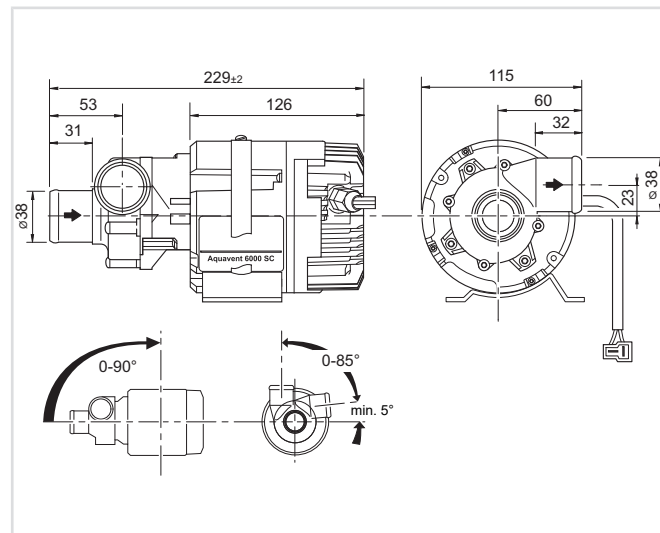

Fig. 14: Installation position U4856

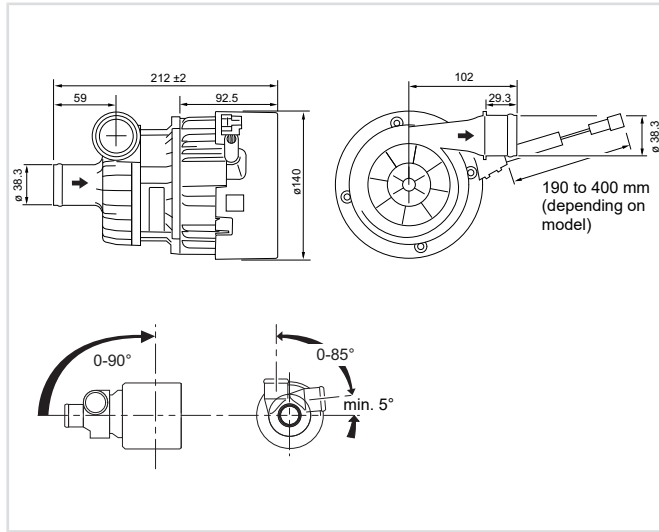

Fig. 15: Installation position SPump 260-500

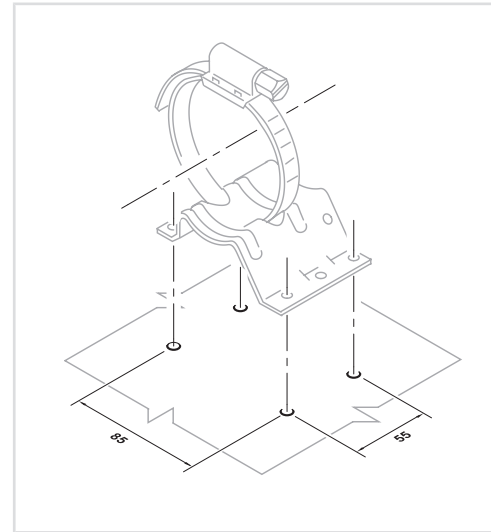

Fig. 16: Hole pattern of circulation pump mounting points



Spheros Germany GmbH
Friedrichshafener Str. 7 - 82205 Gilching - Germany - www.spheros.com