

SPLIT SYSTEMS FOR SHUTTLE AND SCHOOL BUSES

# TROPICOOOL

25074 SKIRT MOUNTED CONDENSER



## PERFORMANCE, RELIABILITY & LOOKS

Spheros provides the best performance and reliability for the application your vehicle requires by manufacturing several different condenser designs. Certain applications provide a more aesthetic OEM look to the bus by eliminating the need to cut intakes in the skirt of the bus.

[WWW.SPHEROS.COM/US](http://WWW.SPHEROS.COM/US)

**SPHEROS**

# 25074 SKIRT MOUNTED CONDENSER

## HIGHLIGHTS



### Design

- Designed to be skirt mounted
- High performance motors with extended brush life
- Fabricated from galvanized steel & covered in corrosion resistant epoxy for durability
- Inlet filter on condenser protects coil from contaminants



### Environmental Friendliness

- High performance parallel flow condenser
- Highly efficient all aluminum micro channel coil



### Features

- 3 11" diameter high performance fans covering a larger percentage of surface area on condenser coil
- Easy Installation without having to cut intakes in skirt of bus-school bus

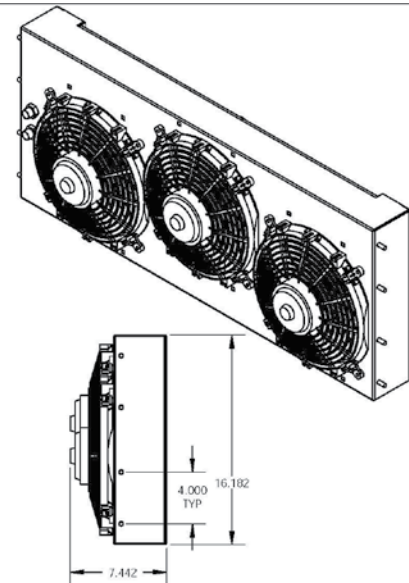
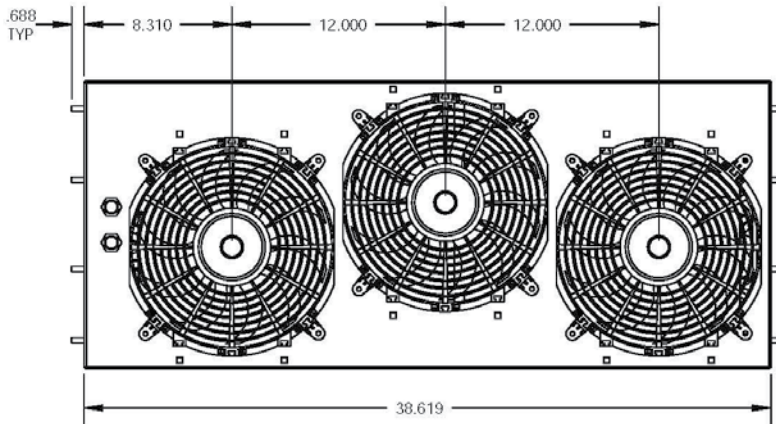

## TECHNICAL DATA

Model	Up to Cooling Capacity	Power Consumption	Nominal Voltage	Dimensions W x H x D	Weight
25074	78,000 BTU/h	25 Amps	12V	39 x 7 x 16 in	60 lbs.