

SPLIT SYSTEMS FOR SHUTTLE AND SCHOOL BUSES

TROPICOOOL

25065 SKIRT MOUNTED CONDENSER



PERFORMANCE, RELIABILITY & LOOKS

Spheros provides the best performance and reliability for the application your vehicle requires by manufacturing several different condenser designs. Certain applications provide a more aesthetic OEM look to the bus by eliminating the need to cut intakes in the skirt of the bus.

WWW.SPHEROS.COM/US

SPHEROS

25065 SKIRT MOUNTED CONDENSER

HIGHLIGHTS



Design

- Designed to be skirt mounted
- High performance motors with extended brush life
- Fabricated from galvanized steel & covered in corrosion resistant epoxy for durability
- Inlet filter on condenser protects coil from contaminants



Environmental Friendliness

- High performance parallel flow condenser
- Highly efficient all aluminum micro channel coil



Features

- Two 14" diameter high performance fans covering a larger percentage of surface area on condenser coil
- Easy Installation without having to cut intakes in skirt of bus-school bus

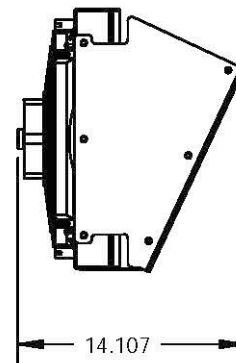
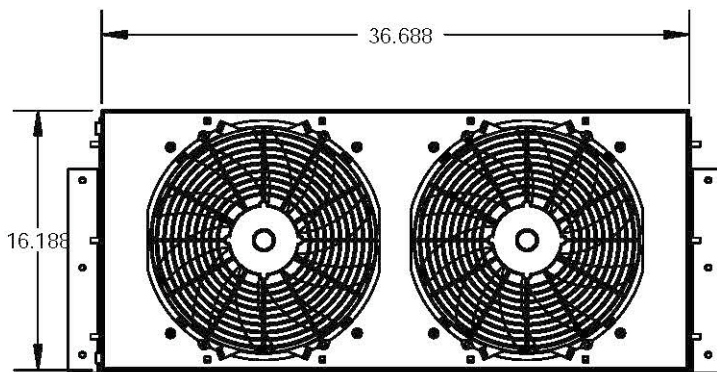

TECHNICAL DATA

Model	Up to Cooling Capacity	Power Consumption	Nominal Voltage	Dimensions W x H x D	Weight
25065	83,000 BTU/h	22 Amps	12V	37 x 3 x 16 in	51 lbs.