

SPLIT SYSTEMS FOR SHUTTLE AND SCHOOL BUSES

TROPICOOOL

25063 SKIRT MOUNTED CONDENSER



PERFORMANCE, RELIABILITY & LOOKS

Spheros provides the best performance and reliability for the application your vehicle requires by manufacturing several different condenser designs. Certain applications provide a more aesthetic OEM look to the bus by eliminating the need to cut intakes in the skirt of the bus.

25063 SKIRT MOUNTED CONDENSER

HIGHLIGHTS



Design

- Designed to be skirt mounted
- High performance motors with extended brush life
- Fabricated from galvanized steel & covered in corrosion resistant epoxy for durability
- Inlet filter on condenser protects coil from contaminants



Environmental Friendliness

- High performance parallel flow condenser
- Highly efficient all aluminum micro channel coil



Features

- One 14" diameter high performance fan covering larger percentage of surface area on condenser coil
- Easy Installation without having to cut intakes in skirt of bus-school bus

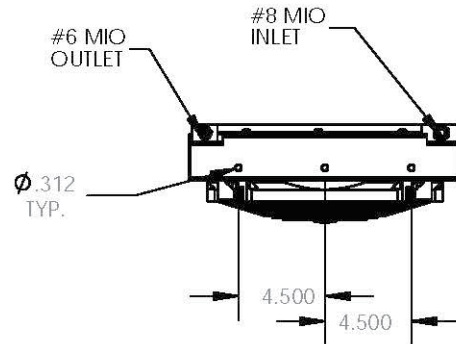
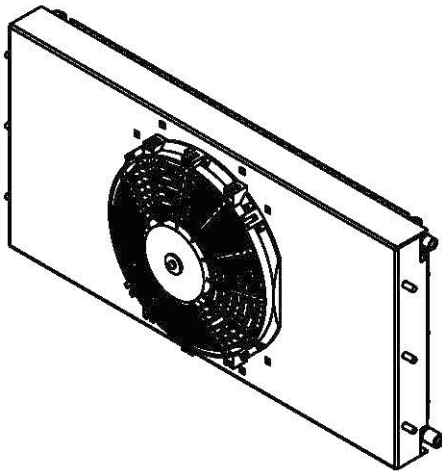

TECHNICAL DATA

Model	Up to Cooling Capacity	Power Consumption	Nominal Voltage	Dimensions W x H x D	Weight
25063	40,000 BTU/h	9 Amps	12V	30 x 5 x 14 in	22 lbs.