

THERMO H PLUS



BECAUSE PRE-GLOWING SAVES COSTS...

...and protects the environment. Our hybrid Thermo H plus heater combines the advantages of the two forms of bus heating energy in one device: electrical and diesel. The bus can be preheated emission-free before setting off and boosted with diesel power at low outside temperatures when the vehicle is moving. This avoids unnecessary burden on the traction battery storage.

HIGHLIGHTS



Low life-cycle costs

- Use of proven components from Thermo plus and Thermo AC/DC
- Low maintenance



Environmentally friendly

- Emission-free pre-heating in enclosed spaces and at the depot
- Booster heating in zero emission zones
- Electric part almost noiseless



Comfort

- Different performance classes
- Independent heating with diesel
- Preconditioning of electric components
- On-/Off-board appliance

Installation dimensions for Thermo H plus

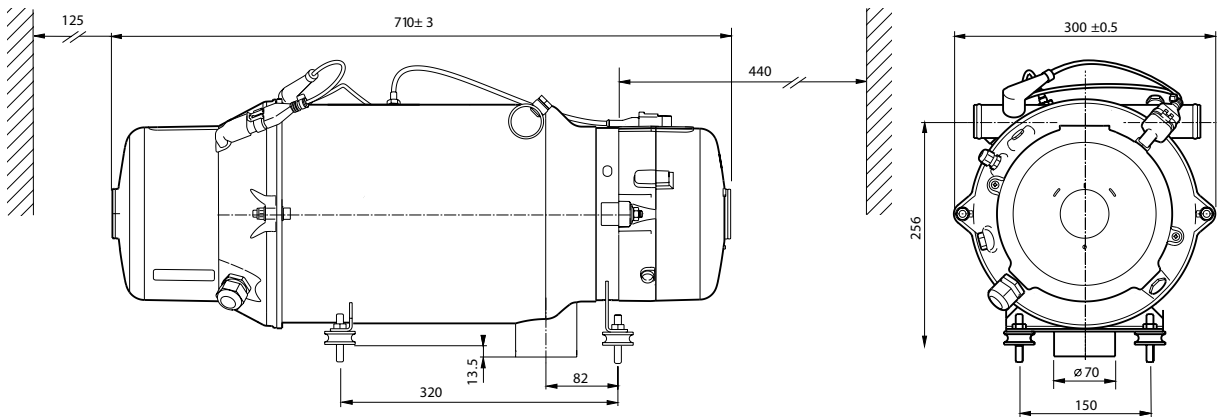

TECHNICAL DATA

Technical Data – Electrical part

Versions	AC070	AC140	AC200	DC070	DC140	DC200
Heat output (kW)	7	14	20	7	2 x 7	20
Power consumption (kW)	7	14	20	7	2 x 7	20
Rated voltage (V)	400	400	400	690	600	690

Technical Data – Diesel part

Versions	160	230	300	350
Heat output (kW)	16	23	30	35
Power consumption (W)	65	60	90	120
Rated voltage (V)	24	24	24	24
Fuel consumption (kg/h)	1.6	2.5	3.0	3.6

Various combinations on request

Technical Data – General

Dimensions L x W x H (mm)	710 x 300 x 350
Weight of heater (kg)	32