

SPLIT SYSTEMS FOR SPECIALITY AND EMERGENCY VEHICLES

TROPICOOOL

25015 SERIES CONDENSER



PERFORMANCE, RELIABILITY & LOOKS

Valeo Thermal Commercial Vehicles provides the best performance and reliability for the application your vehicle requires by manufacturing several different condenser designs keeping in mind the speciality and emergency vehicle market.

BEST-BUS-CLIMATE.COM/US



25015 SERIES CONDENSER

HIGHLIGHTS



Design

- Designed to be skirt mounted
- High performance motors with extended brush life
- Fabricated from galvanized steel & covered in corrosion resistant epoxy for durability
- Inlet filter on condenser protects coil from contaminants



Environmental Friendliness

- High performance parallel flow condenser
- Highly efficient all aluminum micro channel coil



Features

- Two 11" diameter high performance fans covering a larger percentage of surface area on condenser coil

- Standard ambulance condenser
- White powder coat finish for durability

Key Components

- Coil: 11471713D
- Fan: 18000003B (2)

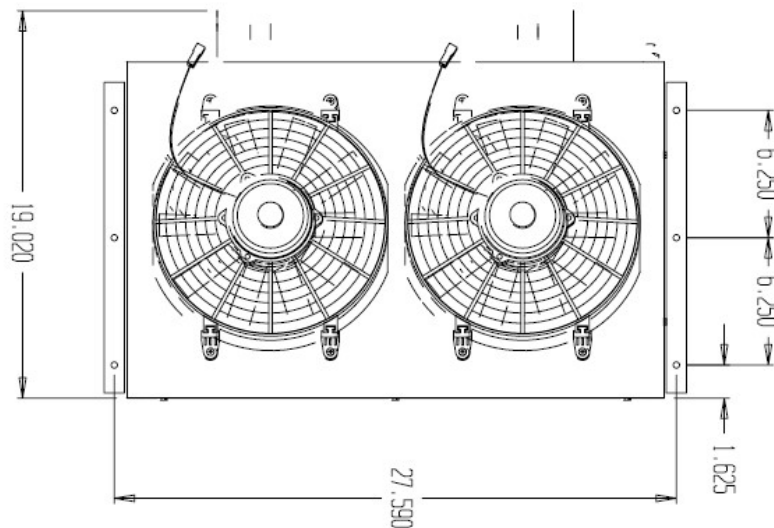

TECHNICAL DATA

| Model | Up to Cooling Capacity | Power Consumption | Nominal Voltage | Dimensions W x H x D | Weight |
|-------|------------------------|-------------------|-----------------|----------------------|---------|
| 25014 | 40,000 BTU/h | 18 Amps | 12V | 30 x 7 x 19 in | 48 lbs. |



Valeo Thermal Commercial Vehicles North America, Inc.
 22150 Challenger Drive Elkhart, IN 46514
 Phone 574-264-2190 - Toll free 800-462-6322
www.valeo-thermalbus.com/us - tcv.na-sales.mailbox@valeo.com