

**Thermo plus 160**

**Thermo plus 230**

**Thermo plus 300**

**Thermo plus 350**

**Thermo plus Rail**

**Workshop Manual**

## 1 Introduction

1.1	Content and purpose	101
1.2	Effectivity of the workshop manual	101
1.3	Meaning of highlighted content	101
1.4	Symbols	101
1.5	Further documentation to be used	101
1.6	Safety information and regulations	101
1.6.1	General safety regulations	101
1.6.2	Other safety information	102
1.7	Suggestions for improvement and change	102

## 2 Technical Data

2.1	Electrical components	201
2.2	Fuel	201

## 3 Description of assemblies and components

3.1	Burner head	302
3.1.1	Combustion air fan	302
3.1.2	Control device	302
3.1.3	Fuel pump	304
3.1.4	Electronic ignition unit with ignition electrodes	305
3.1.5	Nozzle block preheater	305
3.1.6	Temperature sensors with water temperature sensor and integrated overheating protection	305
3.2	Heat exchanger	307
3.3	Combustion chamber	307
3.4	Circulating pump	307
3.5	Fuel filter	308

## 4 Heater functions

4.1	General heater functionality description	401
4.2	Operational heater sequence	402
4.2.1	Switching on and start	402
4.2.2	Heating operation	402
4.2.3	Switching off	403
4.3	Diagnostic interface and (Diagnosis Thermo Test) DTT diagnosis	403
4.4	Fault lock-out and heater lock-out	404
4.5	Fault lock-out	404
4.5.1	Malfunctions during switching-on and start procedure	404
4.5.2	Malfunctions during heater operation	404
4.5.3	Malfunctions during purge cycle	404
4.5.4	Fault lock-out release and error clearance	405
4.6	Heater lock-out	405
4.6.1	Heater lock-out release	405

## 5 Troubleshooting

5.1	General	501
5.2	Disconnecting the heater from the vehicle electrical system	501
5.3	General error symptoms	501
5.4	Error indication	504
5.5	Error symptoms during functional tests with malfunction code output or diagnosis	505
5.5.1	Error symptom "No start within safety period"	505
5.5.2	Error symptom "Flame interruption"	505

5.5.3	Error symptom "Low voltage"	507
5.5.4	Error symptom "Extraneous light detected prior to ignition or during purge cycle"	508
5.5.5	Error symptom "Flameguard defective"	509
5.5.6	Error symptoms "Temperature sensor / overheating protection defective" and "Overheating"	509
5.5.7	Error symptom "Circulating pump defective"	509
5.6	Individual component tests	510
5.6.1	General visual inspection	510
5.6.2	Heat exchanger visual inspection	510
5.6.3	Combustion chamber visual inspection	510
5.6.4	Check of the temperature sensor with integrated overheating protection	511
5.6.5	Fan and combustion air intake line visual inspection	512
5.6.6	Burner motor inspection	512
5.6.7	Electronic ignition unit inspection	513
5.6.8	Ignition electrode inspection	514
5.6.9	Flameguard inspection	514
5.6.10	Fuel pump inspection	515
5.6.11	Solenoid valve inspection	516
5.6.12	Nozzle block preheater inspection	517
5.6.13	Circulating pump inspection	518
<b>6</b>	<b>Wiring diagrams</b>	
6.1	General	601
<b>7</b>	<b>Servicing</b>	
7.1	General	701
7.1.1	Heater servicing	701
7.2	Servicing	701
7.2.1	Periodic heater maintenance	701
7.2.2	CO <sub>2</sub> content adjustment	701
<b>8</b>	<b>Burner head, components and heater removal and installation</b>	
8.1	General	801
8.2	Burner head removal and installation	802
8.3	Removal and installation of the temperature sensor with integrated overheating protection	803
8.4	Hood removal and installation	803
8.5	Fan wheel removal and installation	803
8.6	Electronic ignition unit and ignition electrode removal and installation	804
8.7	Control device removal and installation	805
8.8	Fuel pump removal and installation	805
8.9	Solenoid valve removal and installation	807
8.10	Nozzle block preheater removal and installation	808
8.11	Fuel nozzle removal and installation	809
8.12	Combustion chamber removal and installation	809
8.13	Heat exchanger removal and installation	810
8.14	Heater removal and installation	810
8.15	Start-up after burner head or heater installation	811
8.15.1	Bleeding the fuel system	811
8.15.2	Bleeding of the coolant circuit	811
<b>9</b>	<b>Modifications and retrofits</b>	
9.1	Dust protection for the flame guard	901
9.1.1	Dust protection kit	902
9.1.2	Installation	902

**10 Packing/storage/shipping**

10.1	General	1001
------	---------	------

**Attachment**

	Periodic heater maintenance	A-1
--	-----------------------------	-----

**Link list**

<b>Keyword</b>	<b>Link</b>	<b>page</b>
Pumps	<a href="http://www.valeo-thermalbus.com/eu_en/Service/Downloads/Pumps">http://www.valeo-thermalbus.com/eu_en/Service/Downloads/Pumps</a>	307
Spare parts and accessories	<a href="http://www.valeo-thermalbus.com/eu_en/Service/Spare-Parts-Accessories/Heating-systems/Thermo-Plus">http://www.valeo-thermalbus.com/eu_en/Service/Spare-Parts-Accessories/Heating-systems/Thermo-Plus</a>	307
Technical-Updates-TI	<a href="http://www.valeo-thermalbus.com/eu_en/Service/Technical-Updates-TI/Heating-systems">http://www.valeo-thermalbus.com/eu_en/Service/Technical-Updates-TI/Heating-systems</a>	307
Download	<a href="http://www.valeo-thermalbus.com/eu_en/Service/Downloads/Heating-systems/Diagnostic-Preheater-Fuel-Filter-Software">http://www.valeo-thermalbus.com/eu_en/Service/Downloads/Heating-systems/Diagnostic-Preheater-Fuel-Filter-Software</a>	403

## 1 Introduction

### 1.1 Content and purpose

This workshop manual is used during maintenance and repair of water heaters (further referred to as heaters) Thermo plus 160, plus 230, plus 300 and plus 350.

#### ATTENTION:

**Work on the heater may only be performed by briefed and/or trained by Valeo personnel.**

### 1.2 Effectivity of the workshop manual

The workshop manual applies to heaters listed on the title page of this document.

It may be subjected to modifications and amendments.

The respectively currently effective version is binding. This version can be found on the Valeo website under Service/Downloads/Heating systems.

### 1.3 Meaning of highlighted content

Throughout this manual the emphasized words Warning!, Caution!, ATTENTION: and NOTE: used as follows:



This caption is used to indicate possible severe injuries or fatal accidents if instructions or procedures are carried out incorrectly or entirely disregarded.



This caption is used to indicate possible minor injuries if instructions or procedures are carried out incorrectly or entirely disregarded.

#### ATTENTION:

This caption points to actions which may cause material damage.

#### NOTE:

This caption is used to draw attention to an important feature.

### 1.4 Symbols



Symbol tightening torque value:

Identifies in graphics parts (eg nuts, bolts) that are to be mounted with a specific tightening torque. The torque values are shown at the symbol and are binding.

### 1.5 Further documentation to be used

The use of additional service literature is required. References are provided in the workshop manual at appropriate locations.

Use the following documents during operation and maintenance of the heaters:

- Operating and Service Instructions
- Installation Instructions
- Technical Information (TI)
- Spare Parts List
- Operating Instructions for the Spheros Thermo Test, further referred to as STT Diagnosis

### 1.6 Safety information and regulations

Basically, general accident prevention provisions and the valid industrial safety directions must be adhered to. "General Safety Regulations" which exceed the framework of these provisions are listed below. The specific safety regulations which affect the present manual are issued highlighted in the individual sections or procedures.

#### 1.6.1 General safety regulations



**Read the Thermo plus Operating and Service Instructions before operating the heater for first time.**

**Familiarize yourself with the Thermo plus Installation Instructions before you make any modifications to the existing heater installation.**

#### NOTE:

The Thermo plus Operating and Service Instructions contain safety instructions and regulations to be followed for safe operation of the heater.

The Thermo plus Installation Instructions contain the statutory regulations and other safety hints and regulations for the proper installation of the heater.

## 1.6.2 Other safety information

### 1.6.2.1 Temperature sensors

**ATTENTION:**

The temperature sensors cable may not be mechanically stressed (pull on the cable, carry the heater at the cable etc.).

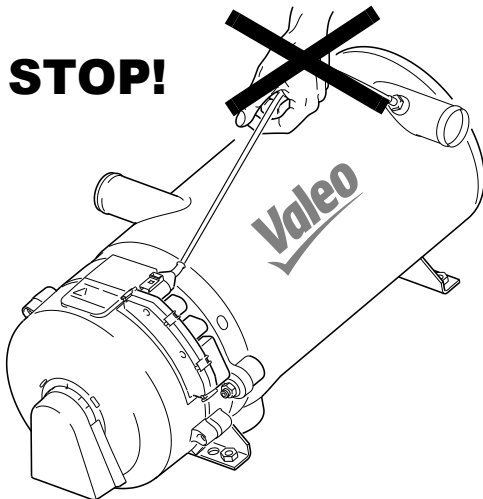

## 1.7 Suggestions for improvement and change

Please direct any complaints, improvement or modification suggestions regarding this manual to:

[service-valeobus@valeo.com](mailto:service-valeobus@valeo.com)

## 2 Technical Data

Unless limiting values are defined, the technical data should be understood with tolerances of  $\pm 10\%$  common for heaters at an ambient temperature of  $+20^{\circ}\text{C}$ , and at nominal voltage.

Table 201 Technical Data

Heater		Thermo plus 160	Thermo plus 230	Thermo plus 300	Thermo plus 350
ECE Type Approval Number	E1 122R 00	0580	0466	0467	0468
Kind of construction		High pressure atomizer			
Heating flow (at ambient temperature of $20^{\circ}\text{C}$ )	kW (kcal/h)	16 (13 800)	23 (20 000)	30 (26 000)	35 (30 000)
Fuel		Diesel / Heating oil			
Fuel consumption	kg/h	1.6	2.5	3.0	3.6
Rated voltage	V =	24			
Operating voltage range	V =	20.5 ... 30			
Rated power consumption at 24V *	W	65	60	90	120
Max. permitted temperature of sucked combustion air at $< 85^{\circ}\text{C}$ ambient temperature	$^{\circ}\text{C}$	85			
Max. permitted temperature of sucked combustion air at $> 85^{\circ}\text{C}$ ambient temperature	$^{\circ}\text{C}$	60			
Permitted ambient temperature during operation	$^{\circ}\text{C}$	-40...+ 100			
Permitted storage temperature	$^{\circ}\text{C}$	-40...+ 110			
Permitted operating overpressure	bar	max. 2.0			
Capacity of the heat exchanger	l	1.8			
Minimum water flow **	l/h	1400	1900	2400	2700
Minimum capacity of the water system	l	25			
CO <sub>2</sub> in exhaust gas at rated voltage	Vol %	9.5 + 1.0	9.0 + 1.5	9.5 + 1.5	9.5 + 1.5
Heater dimensions (tolerance $\pm 3$ mm)	mm	Length 540 / Width 250 / Height 222			
Weight	kg	16.5	16.8		

\* without circulating pump

\*\* Minimum water flow at coolant temperatures above  $50^{\circ}\text{C}$   
Below  $50^{\circ}\text{C}$  a lower water flow is permitted, if the occurrence of vapor bubbles due to local overheating safely can be excluded.

### 2.1 Electrical components

Control unit, circulating pump, solenoid valve, electronic ignition and the digital timer are designed for 24V nominal voltage. The burner motor supply voltage is controlled by the control device.

#### NOTE:

Circulating pumps must be assigned to the heaters according to the flow resistance in the coolant circulation system.

### 2.2 Fuel

Suitable fuel is the diesel fuel specified by the vehicle manufacturer. Only the one on the model plate of the heater specified fuel must be used.

The following table lists the by Valeo approved fuels and their specifications.

Fuel	Requirements acc.	Remarks
Summer Diesel	DIN EN 590	
Winter Diesel	DIN EN 590	
Arctic Diesel and Diesel for a strong winter climate	DIN EN 590	
Bio Diesel (FAME)*	DIN EN 14214	see TI Fuels
Paraffinic diesel fuel from synthesis or hydro-generation (HVO)*	DIN EN 15940	only selected fuels see TI Fuels

\* Further information on approved fuels contains the TI (Technical Information) Fuels.  
It can be found on the Valeo website under Service/ Technical Updates/Heating systems.

In case of air temperatures below 0°C a commercially available winter Diesel fuel, at temperatures below -18°C a Diesel for arctic climate conditions must be used.

The usage of flow improvers respectively additives is permitted. There are no negative influences due to additives known.

#### ATTENTION:

**While using the fuels, their operating limits must be considered and if necessary, suitable measures (nozzle preheating, electrical heated filter) should be applied.**

**If fuel is supplied from the vehicle tank, follow the vehicle manufacturer's instructions on additives.**



### 3 Description of assemblies and components

The heaters Valeo Thermo plus 230, plus 300 and plus 350 are used in conjunction with the vehicle heating system

- to heat the passenger compartment
- to defrost the windows
- to preheat water-cooled vehicle engines.

The water heater operates independently from the vehicle engine and is connected to the cooling system, the fuel system and the electrical system of the vehicle. It is bolted down to the vehicle chassis or is secured using an additional cross beam.

Heat is generated by combustion of liquid fuels. Via the heat exchanger of the heater, the heat is dissipated to a coolant circuit. The adaptation to the changing demand of heat is reached by intermittent operation (intermittent mode).

The control device controls on the basis of the signals of a temperature sensor the on and off switching of the burner.

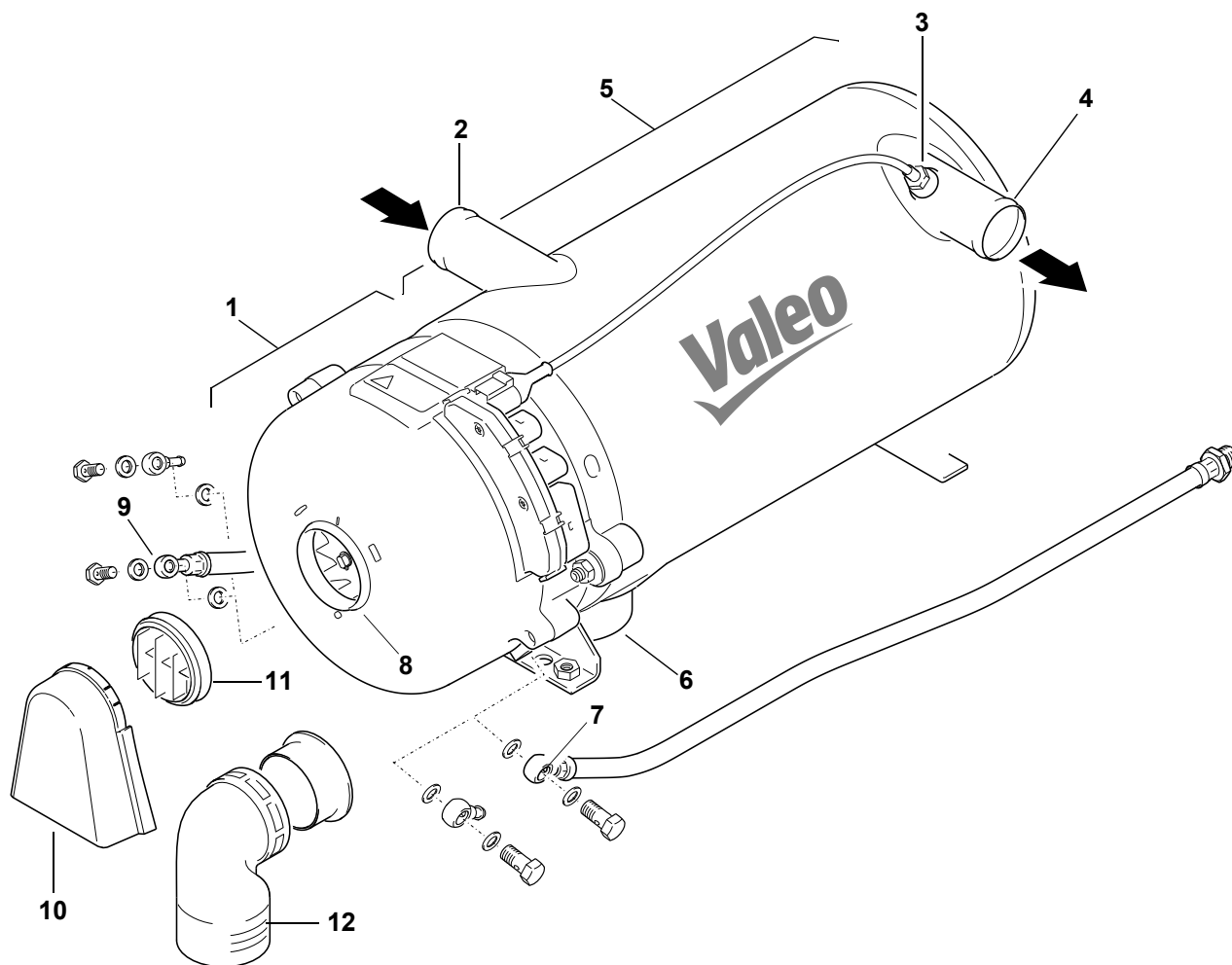

- |                          |  |
|--------------------------|--|
| 1 Burner head            | 9 Fuel, supply   |
| 2 Coolant, intake        | 10 Splashguard<br>(grid alternative)                       |
| 3 Temperature sensors    | 11 Grid  |
| 4 Coolant, outlet        | 12 Intake air elbow<br>incl. adapter<br>(grid alternative) |
| 5 Heat exchanger         |  |
| 6 Exhaust outlet         |  |
| 7 Fuel, return           |  |
| 8 Combustion air, intake |  |

Fig. 301 Heater overview

The heaters of the Thermo plus series basically consist of the main components:

- burner head
- combustion chamber
- heat exchanger

### 3.1 Burner head

The burner head consists of the components

- combustion air fan
- control device with burner motor and flame guard
- fuel pump with solenoid valve and atomizer nozzle
- electronic ignition unit with ignition electrodes
- nozzle preheater (optional)
- disc with sight window

#### 3.1.1 Combustion air fan

The combustion air fan (Fig. 302) transports the air required for combustion from the combustion air intake to the combustion chamber.

The combustion air fan consists of the burner motor at the control device and the fan wheel. Air is drawn in through the air intake opening in the hood.

This air intake opening is equipped with a splashguard, a protective grid or an intake air elbow (see Fig. 301).

#### 3.1.2 Control device

The control device (Fig. 303) ensures the operating sequence and burner operation monitoring. It constitutes a unit with the burner motor.

The control device is mounted onto the front of the burner housing, under the hood. It protrudes with four external electric ports out the heater:

- Port C - power/control,
- Port P - circulating pump,
- Port T - temperature sensors and
- Port G - diagnosis interface

Internally the control device provides the ports

- connector V - nozzle preheater,
- connector M - solenoid valve, and
- connector Z - electronic ignition unit.

##### 3.1.2.1 Burner motor

The control device constitutes a unit with the brushless EC motor which is installed at the burner housing. This arrangement allows its direct power supply via the control device board. The speed measurement is done by a Hall sensor.

The shaft of the external rotor motor protrudes through the control device. To the forward end the fan wheel is installed and on the backside of the control device via a coupling the fuel pump is driven.

The speed of the burner motor is controlled depending on the operating status by the control device.

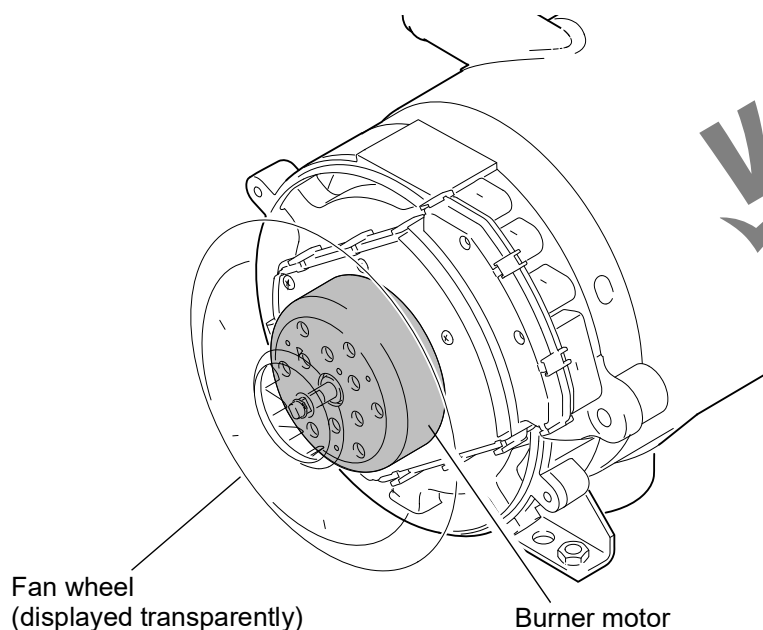

Fig. 302 Combustion air fan

3.1.2.2 Flameguard

The flameguard (see Fig. 304) is integrated in the control device.

The flameguard monitors the combustion flame condition

during heater operation.

The flame guard is a photo transistor that changes its resistance depending on the incident light.

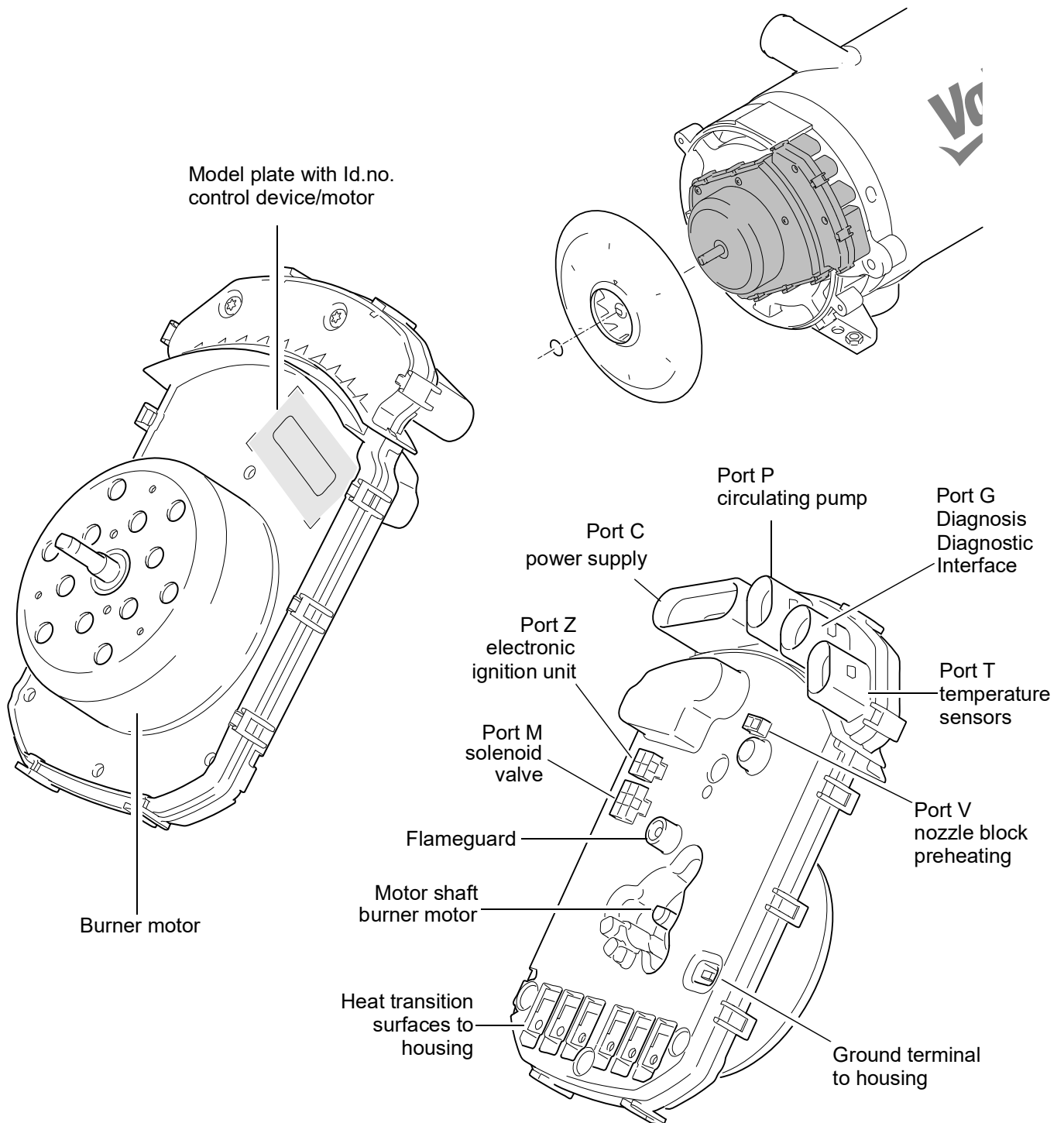

Fig. 303 Control device SG1589

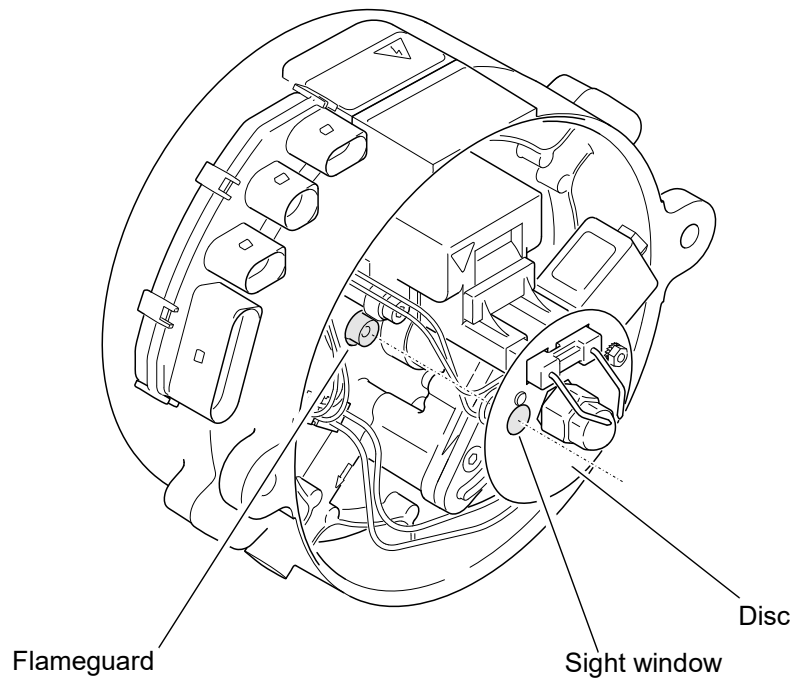

Fig. 304 Flameguard

### 3.1.3 Fuel pump

The fuel pump is responsible for fuel supply. (Fig. 305). The pump is driven by the burner motor via a coupling. Fuel is compressed in the fuel pump to approx. 10 bar and

atomized by the atomiser nozzle.

The solenoid valve installed at the fuel pump opens and closes the fuel supply to the atomizer nozzle. For all three heating capacity classes the same fuel pump is installed.

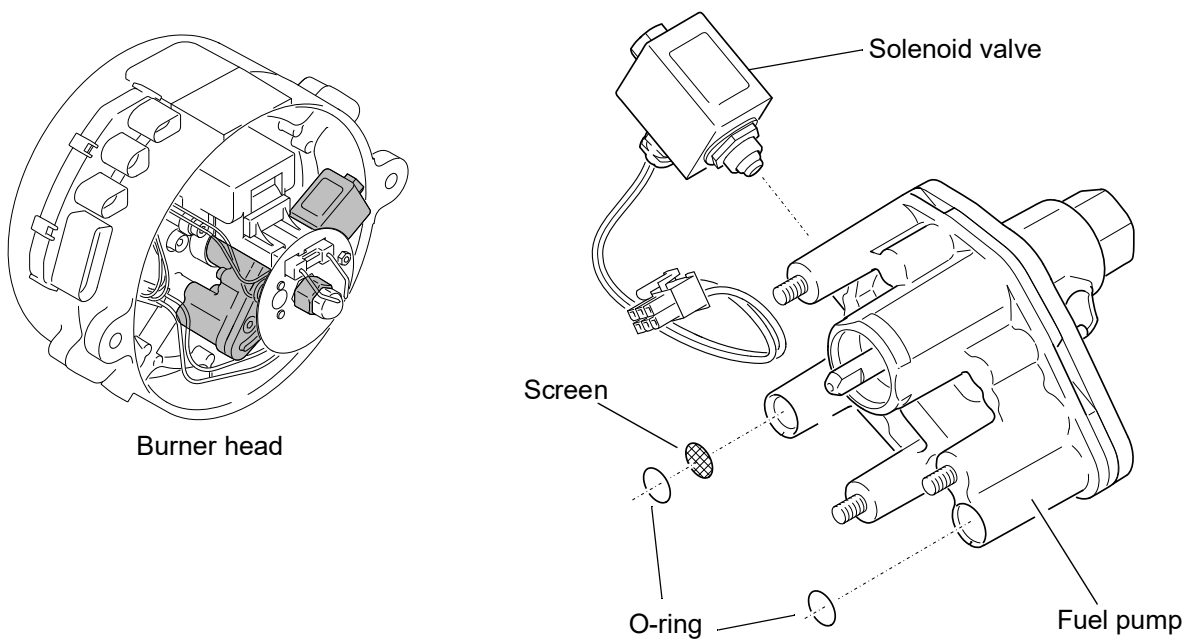

Fig. 305 Fuel pump with solenoid valve

The fuel pump can be used in dual-line operation only (fuel supply and return line).

If the heater is operated with

- a long fuel supply line
- check valves in the fuel supply and return line
- a fuel filter in the fuel supply line

the fuel supply line must be filled prior to first heater start-up (see 8.15).

### 3.1.4 Electronic ignition unit with ignition electrodes

The electronic ignition unit (Fig. 306) induces the high voltage required for ignition of the fuel-air mixture. Ignition is triggered by a high voltage spark, which is initiated on the ignition electrodes.

### 3.1.5 Nozzle block preheater

At very low temperatures, it can cause a strong changed viscosity of the fuel. This may cause heater malfunctions due to insufficient atomization of the fuel. Depending on the fuel used, these temperatures are different. When used in cold areas or when using fuels other than diesel fuel, is the use of a nozzle block preheater (Fig. 307) recommended.

The nozzle block preheater consists of a heating element and a thermostat. It is powered by the control unit via the fuse supplying the circulation pump and only works if the output of the circulation pump is error-free.

At a temperature below 5 °C, the thermostat allows the current to flow to the heating element and the heating element heats the nozzle block and thus the fuel and the

atomizer nozzle.

The control unit defines the preheating time of the heating element, which depends on the water temperature, before the heater starts; it can be up to 120 s. (see chapter 4.2.1)

The fuel viscosity is reduced by the heat of the heating element and the atomization is improved. The heating period of the heating element after the heater start is depending on the temperature of the intake air and the reflected heat from the combustion chamber. Above 8 °C temperature the thermostat switches off the heating element.

The use of the nozzle block preheater is optional. The retrofitting can be done without any changes to the control unit.

### 3.1.6 Temperature sensors with water temperature sensor and integrated overheating protection

The water temperature sensor (Fig. 308) captures the coolant temperature at the heat exchanger outlet as electrical resistance.

This signal is transmitted to the control device, where it is processed.

The overheating protection integrated into the temperature sensor is responsible for temperature limitation.

Overheating protection prevents inadmissibly high heater operating temperatures.

At a temperature greater than 135 °C heater deactivation and interlocking is initiated.

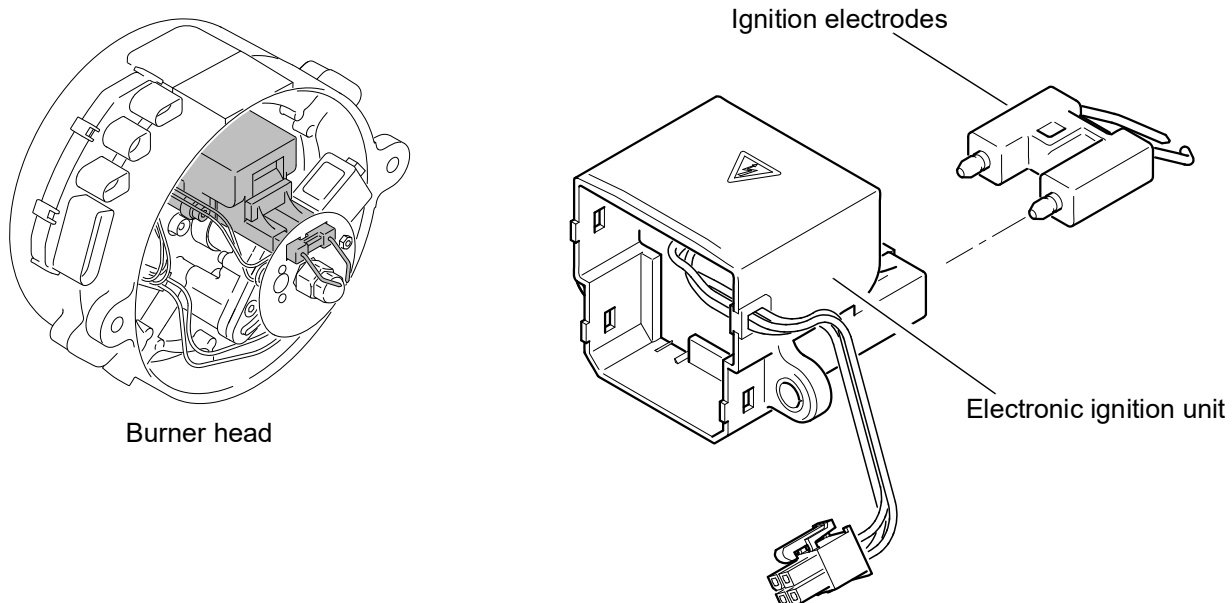

Fig. 306 Electronic ignition unit with ignition electrodes

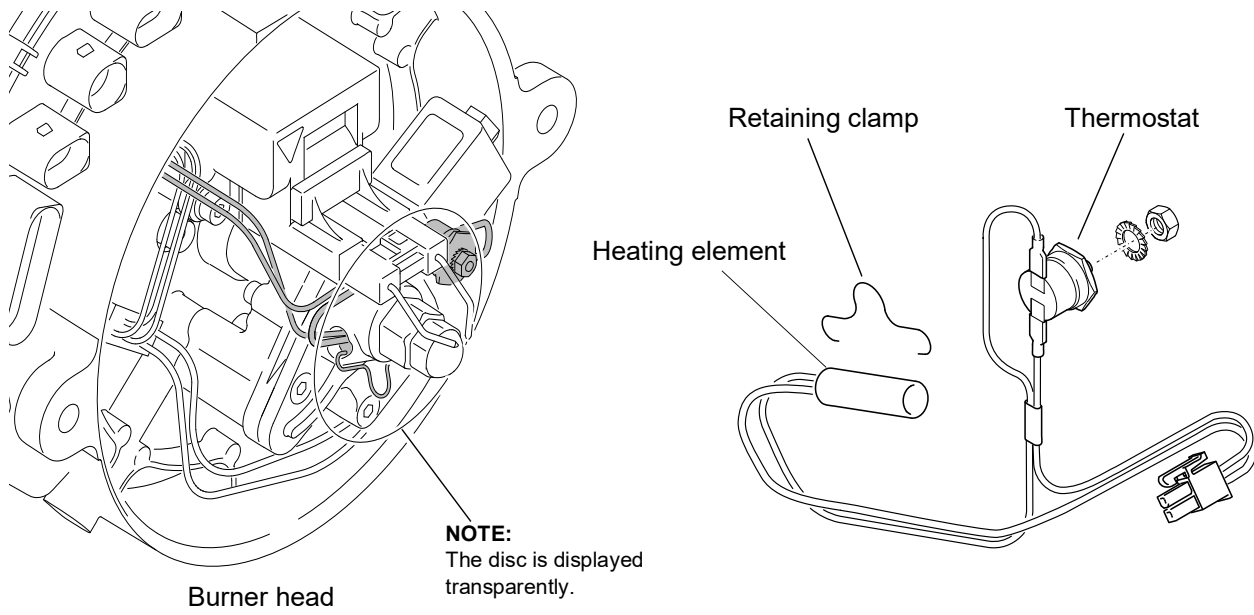

Fig. 307 Nozzle block preheater

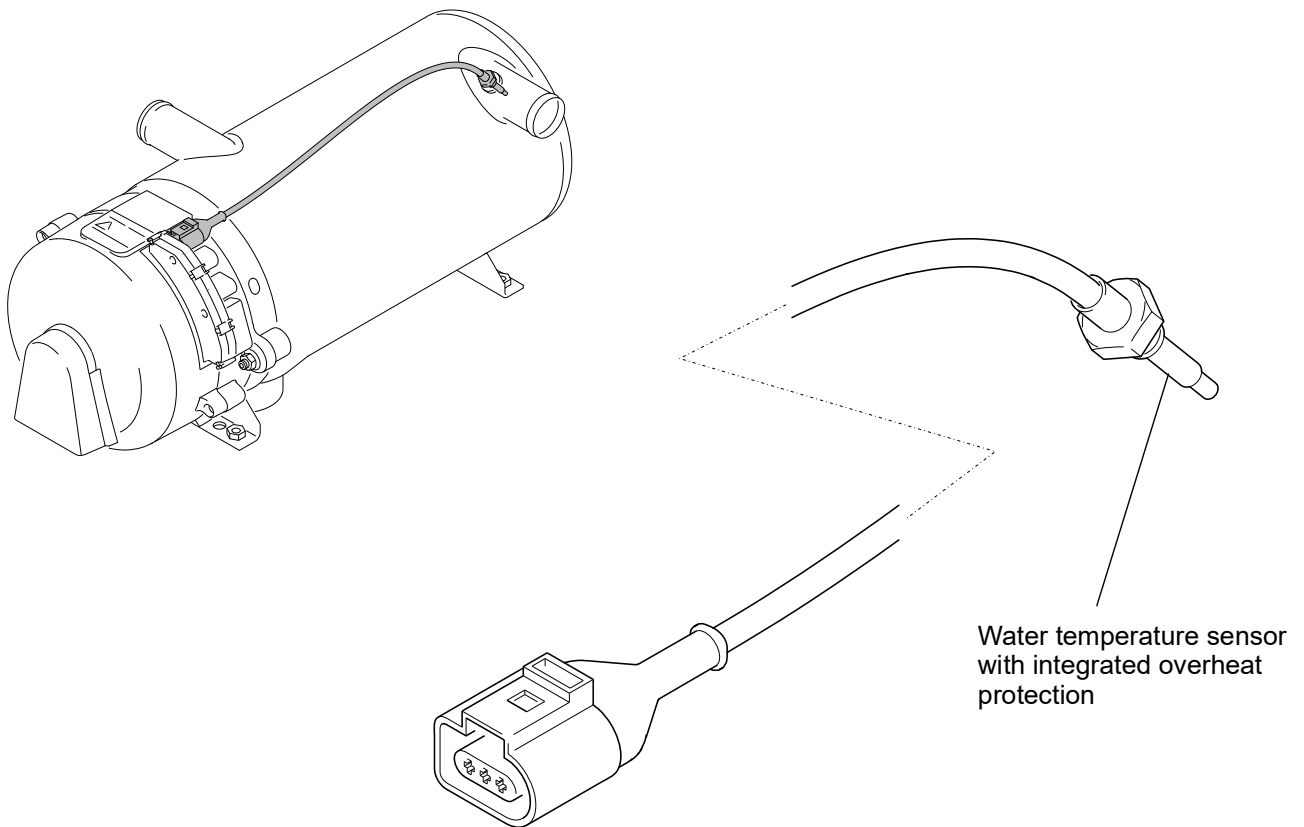

Fig. 308 Temperature sensors

### 3.2 Heat exchanger

The heat exchanger (Fig. 309) transfers the heat generated by combustion to the coolant circulation system. Depending on the system integration a heat exchanger with or without thread in the coolant inlet socket can be installed.

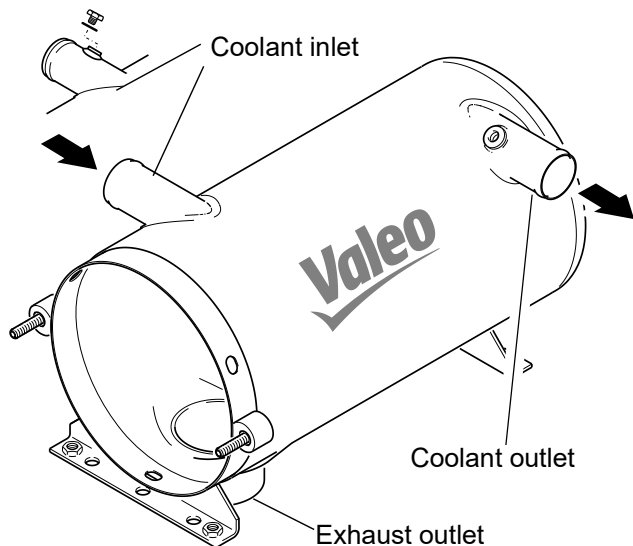

Fig. 309 Heat exchanger

### 3.3 Combustion chamber

The combustion chamber (Fig. 311) is used for generation and combustion of the fuel air mixture. The generated exhaust gas heats the coolant flowing through the heat exchanger.

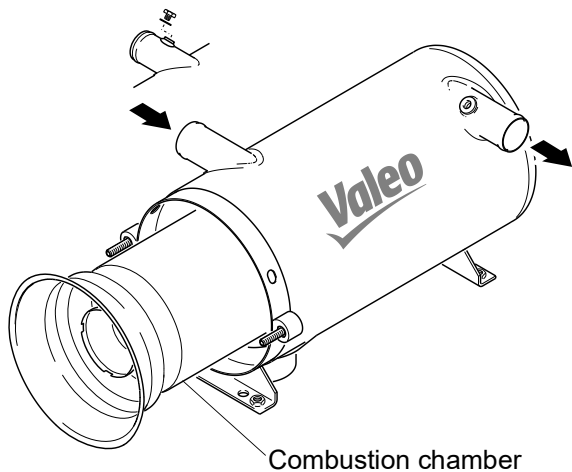
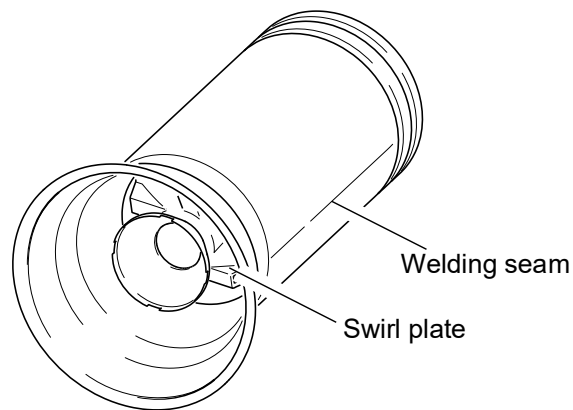

Fig. 310

#### NOTE:

In the heaters are used different combustion chambers depending on the heating capacity class.



23 - 35 kW

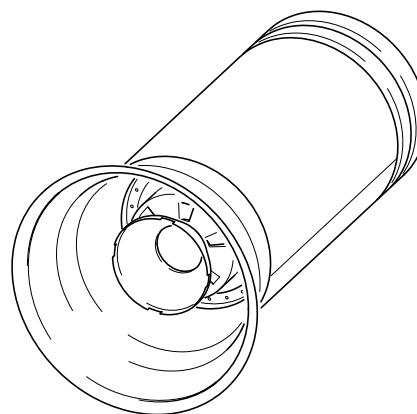

16 kW

Fig. 311 Combustion chamber

### 3.4 Circulating pump

The externally arranged circulating pump ensures coolant transport within the vehicle and/or heater circulation system.

Depending on the application, the circulating pump is switched on via the control device or directly via the vehicle electrical system and operated during the entire heater operation duration.

Further information on the installation and operation of the circulating pump is contained in the Thermo plus Installation Instructions.

All service information regarding your Valeo circulating pump(s) can be found on the Valeo website under [pumps](#).

### 3.5 Fuel filter

As an option a heated fuel filter is available (see [spare parts and accessories](#) on the Valeo-website).

The integrated filter heating is switched on at a fuel temperature of  $\leq 0.5 \pm 2.5$  °C and off at  $\geq 5.5 \pm 2.5$  °C by a temperature switch.

When the heater is operated at low temperatures, depending on fuel used a heated fuel filter must be installed. See [Technical Updates TI](#) on the Valeo-website).



## 4 Heater functions

### 4.1 General heater functionality description

The heater principle is based on a high-pressure atomizer burner and is monitored by an integrated control unit.

The burner motor powers the fan and the fuel pump. The fuel pump is coupled to the motor using a plastic coupling. The fan produces the required combustion air, the combustion air volume is impacted by the burner motor speed. The speed is read and monitored by a Hall sensor.

The speed required for the CO<sub>2</sub> content is determined during first calibration at Valeo and is stored in the control unit.

In a maintenance event the workshop can adjust the CO<sub>2</sub> setting using the DTT diagnosis (Diagnose Thermo Test) (siehe 4.3).

The fuel pressure is generated in the fuel pump and reduced to the required pressure using a pressure limiting valve.

A solenoid valve releases the fuel via the atomizer nozzle for combustion in the combustion chamber.

As an option, the fuel pump can be equipped with a nozzle block preheater. The nozzle block preheater heats the

nozzle holder with the atomizer nozzle at low temperatures, and thus the fuel. The fuel air mixture is ignited in the combustion chamber via a high-voltage ignition spark.

The flame is monitored by a flame detector integrated into the control device.

Depending on the equipment, the heater is switched on and off using a

- digital timer
- switch
- or climate control.

During heating operation the burner is automatically switched on and off. For control a temperature sensor is installed in the coolant outlet of the heat exchanger.

The heater is switched on, when the temperature falls short of a lower temperature threshold, and is switched off, if the upper temperature threshold is reached (see Table 401).

The switching thresholds depend on the operation mode of the heater and are programmed into the control device.

An operation indicator is available for monitoring the operation status of the heater. A flame indication can be optionally installed.

The operation indicator is also used to output error messages via flash code.

Table 401 Water Temperature Control Thresholds (standard data set) \*

Heater	Aux. heating mode (terminal 61)		Parking heating mode		Economy mode	
	on	off (CI)	on	off (CI)	on	off (CI)
Thermo plus 160 Thermo plus 230 Thermo plus 300 Thermo plus 350	72	82	67	77	55	70
Thermo plus 230 Rail Thermo plus 300 Rail Thermo plus 350 Rail	70	85	45	60	25	40

\*) Customer-specific data sets differ

CI: Control idle  
on/off : lower/upper threshold

Aux. heat. mode: Heater is operating, engine is operating

Parking heat. mode: Heater is operating, engine is off

Economy mode: Control temperature is on a lower level

**NOTE:**

Aux. heating mode has priority over the economy mode!

### 4.2 Operational heater sequence

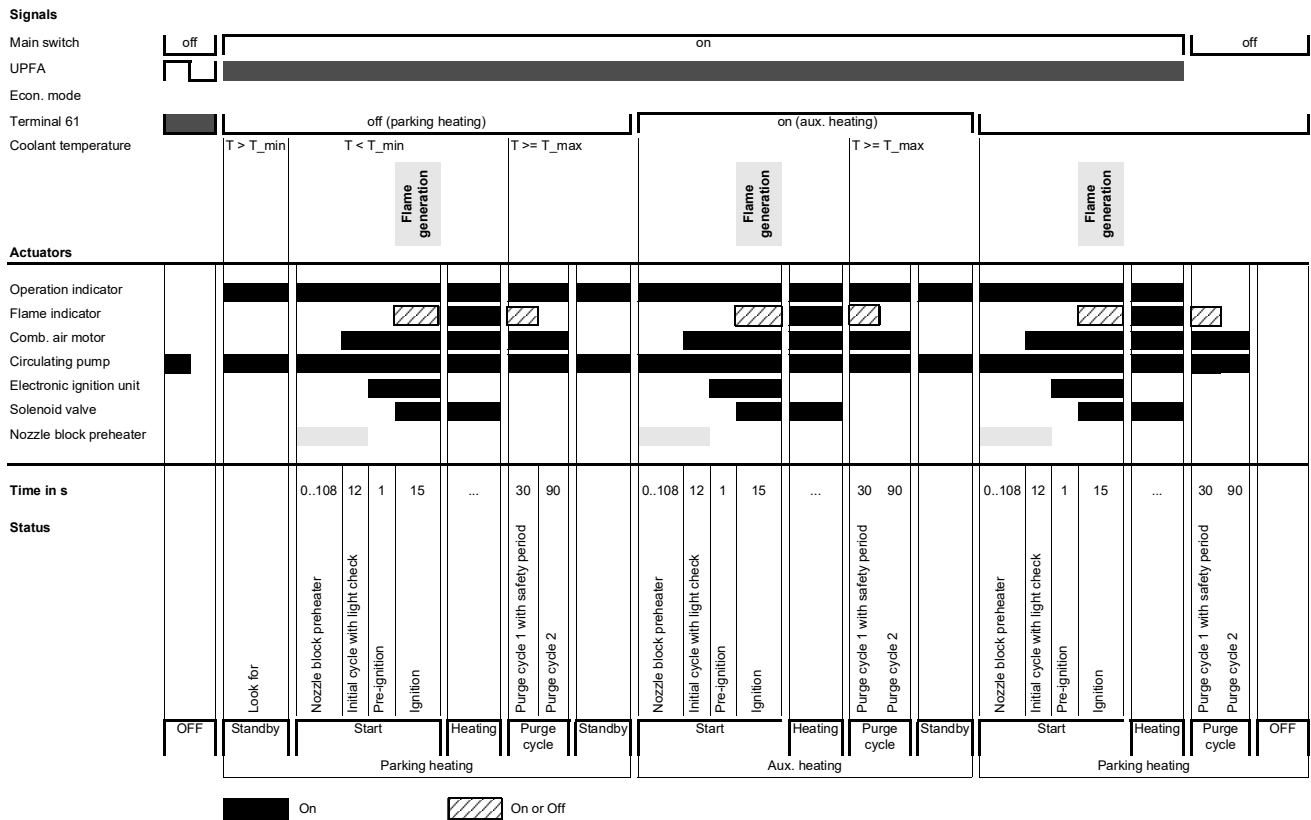

Fig. 401 Operational sequence

#### 4.2.1 Switching on and start

When switched on, the operating display is illuminated, the control unit starts controlled operation and checks the coolant temperature.

If the coolant temperature is below the lower temperature threshold, the initial cycle starts. Combustion air fan and circulating pump are switched on. The initial cycle is used to flush the combustion chamber.

In the start phase until to the pre-ignition the in the control device integrated flameguard must continuously detect „dark“, otherwise it comes to a fault lock-out and the heater changes into the standby.

After approx. 12 seconds (initial cycle time) the high-voltage spark is ignited. Approx. 1 second later the solenoid valve in the fuel pump is opened.

The fuel injected via the atomizer nozzle and mixed with the air of the combustion air fan, is ignited by the ignition spark and burned in the combustion chamber.

The monitoring of the flame is done by the flame guard.

A few seconds after a flame is detected, the control device switches the electronic ignition unit off. Until then the flame is stabilized and the heater is not yet in heating mode.

#### With optional nozzle block preheater:

With activated circulating pump the thermostat at the nozzle block preheater controls its operation. When the ambient temperature is less than 5 °C it is turned on.

The duration of the nozzle block preheating is prolonged, depending on the determined temperature. The burner motor does not run during the entire preheating time. It starts at the latest 12 seconds before the expiry of the determined preheating time with the initial cycle. The time of the initial cycle can thus be extended to a maximum of 108 seconds.

The further procedure is as described.

#### 4.2.2 Heating operation

After the flame is stabilised, the heater is in controlled (normal) operation.

Depending on the coolant temperature, the coolant temperature is maintained at one level by switching the burner alternately on and off.

Once the upper switching threshold is exceeded, heating operation is finished and the purge cycle initiated.

The solenoid valve is closed, the flame expires, however the combustion air fan and the circulating pump continue running.

The purge cycle ends approx. after 120 seconds. The combustion air fan is switched off.  
The heater is in a controlled break.  
The operation indicator is on.  
Once the temperature falls short of the lower switching threshold, the heater restarts burner operation. It runs through the same sequence as the switching-on sequence.

#### 4.2.2.1 Auxiliary heating mode and parking heating mode

From the terminal D+ / +61 the control device receives the information either the vehicle engine is running or not. If the engine is running the heater is in the auxiliary heating mode.  
The switching thresholds are higher than in the parking mode with the engine not running.  
In the parking heating operation an economy mode may be activated.

#### 4.2.2.2 Economy circuit

If the economy circuit is activated (economy mode) the controlled temperatures in the heating system are maintained at a low temperature level. The lower and upper switching threshold are reduced.  
This reduces the heating duration and frequency and thus the fuel consumption. The heater burner output is not reduced.  
In auxiliary heating mode (signal from terminal D+ / +61) saving mode is automatically deactivated.

#### 4.2.2.3 Gradient evaluation

In case of low coolant flow or poor coolant circuit venting the temperature quickly increases in heating operation. The control device recognises the quick temperature increase and automatically sets the upper switching threshold to a lower value.  
The quicker the temperature increases, the lower the switching threshold for starting the controlled break is set. In addition, the burner is also switched back on again after the controlled break at a lower switching threshold. This prevents residual heat triggering the overheating protection.

#### 4.2.2.4 Minimum combustion period

##### NOTE:

Frequent burning time under 120 seconds may result in soot build and increased smoke formation.

A minimum burner combustion period of 120 second is targeted.  
For ambient and operating conditions this target is not

always achieved.

In order to achieve the minimum combustion period, the lower switching threshold is variably adjusted by the control device.

This process is also called hysteresis adaptation and is applied during each heating operation.

If the combustion period falls short of the minimum combustion period of 120 seconds, the lower switching value is lowered by 1K for the following combustion process. The upper switching threshold remains as is. This can be repeated until the minimum combustion period is reached or the lower switching threshold is reduced by 5K.

A further lowering is not possible.

Following a combustion process, where the required minimum combustion period was reached, the lower switching threshold is raised in steps of 1 K, max. up to the initial level.

#### 4.2.3 Switching off

Switching the heater off ends the combustion process. The operation indicator goes out and the purge cycle is initiated.

The solenoid valve closes, the flame expires, the combustion air fan and the circulating pump continue running. The purge cycle ends approx. after 120 seconds. The combustion air fan is switched off.

If a malfunction occurs during purge cycle (e.g. flame detection), the purge cycle may be shorter than 120 seconds.

During purge cycle it is permitted to switch the heater back on. The burner will restart after a purge cycle time of 30 seconds and subsequent initial cycle time.

### 4.3 Diagnostic interface and (Diagnosis Thermo Test) DTT diagnosis

Heaters of the Thermo plus series support diagnostic capabilities. Using the DTT diagnosis adapter, DTT diagnosis and a PC, the heaters in a vehicle can be checked.

Information on the hook-up of the heater to the diagnosis and its usage can be found in the DTT Operation Instructions which are supplied with the device.

The Operation Instructions are also available for [download](#) on the Valeo website.

##### NOTE:

For protection against moisture and contamination ensure that the diagnosis interface is sealed using a dummy plug, if not in use.

#### 4.4 Fault lock-out and heater lock-out

A distinction is made between fault lock-out and heater lock-out.

The lock-outs protect the heater and the surrounding vehicle assemblies against sequence errors after a failure or a malfunction of individual heater components.

In a heater lock-out safety-related components are affected by the failure or malfunction. It may only be released by Valeo trained personnel after eliminating the cause.

Each fault lock-out and heater lock-out is stored in the control device.

#### 4.5 Fault lock-out

If one of the malfunctions listed below occurs, the heater will initiate a fault shut-down, followed by a fault lock-out.

Depending on the error timing, no purge cycle or a 120 seconds purge cycle will be executed.

Flash impulses are outputted via the operation indicator.

**NOTE:**

If the circulating pump is externally actuated it will continue operating, if it is not affected itself.

In case of several sequential fault lock-outs a heater lock-out is initiated (see 4.6).

##### 4.5.1 Malfunctions during switching-on and start procedure

If malfunctions occur during switching-on or during the start process prior to ignition, the heater will be switched off without purge cycle.

The heater is in fault lock-out. The motor stops immediately or does not start.

**Malfunction criteria:**

- Short circuit and/or interruption of electrical components:
  - Circulating pump
  - Electronic ignition unit
  - Optional nozzle block preheater
- Flame or extraneous light detection by the flameguard prior to opening of the solenoid valve.
- No start: No flame detection within 15 seconds after opening the solenoid valve.

- Temperature sensor delivers unacceptable temperature values.
- Burner motor speed signal faulty.
- Voltage falls short of the low voltage threshold of approx. 20.5 V within a duration of 20 seconds after a heating request.
- Voltage exceeds the high voltage threshold of approx. 30 V within a duration of 6 seconds (purge cycle only, no fault lock-out).

##### 4.5.2 Malfunctions during heater operation

In case of malfunctions during heater operation, a 120 seconds purge cycle will be executed first. Subsequently the heater status is switched to fault lock-out.

**Malfunction criteria:**

- Circulating pump - short circuit and/or interruption
- Water temperature greater than the upper switching threshold
- Temperature sensor delivers unacceptable temperature values.
- Heater operation outside the permissible temperature range.
- Burner motor speed signal faulty.
- Flame interruption (combustion interruption for longer than 15 seconds).
- Voltage falls short of the low voltage threshold of approx. 20.5 V within a duration of 20 seconds after a heating request.
- Voltage exceeds the high voltage threshold of approx. 30 V within a duration of 6 seconds (purge cycle is applied only, but no fault lock-out).
- Control device malfunction

##### 4.5.3 Malfunctions during purge cycle

After the purge cycle the heater goes into the fault lock-out.

**Malfunction criteria:**

- Circulating pump - short circuit and/or interruption
- Heater operation outside the permissible temperature range.
- Burner motor speed signal faulty.
- Voltage falls short of the low voltage threshold of approx. 20.5 V within a duration of 20 seconds after a heating request.
- Voltage exceeds the high voltage threshold of approx. 30 V within a duration of 6 seconds (purge cycle is applied only, but no fault lock-out).
- Control device malfunction

#### 4.5.4 Fault lock-out release and error clearance

The fault lock-out is released when the heater is switched off.

After that it will be immediately ready for operation.

The detected error is stored in the error memory and can be read using STT diagnosis. It is possible to delete the stored error using the STT diagnosis

### 4.6 Heater lock-out

**The heater lock-out overrides the standard fault lock-out.**

If the heater lock-out is active, neither start nor purge cycle are executed after switching the heater back on. Prior to restarting the heater troubleshooting must be performed by personnel trained by Valeo in order to identify the root cause.

After that the heater interlock can be released (see 4.6.1).

**NOTE:**

If malfunctions occur during switching-on or during the start process prior to ignition, the heater will be switched off without purge cycle.

The heater is in the heater lock-out.

The burner motor stops immediately or does not start.

Besides that a purge cycle between 30 seconds and 60 seconds is performed depending on error type and timing. Subsequently the heater status is switched to heater lock-out.

If the circulating pump is externally actuated it will continue operating, if it is not affected itself.

**Heater lock-out causes:**

- Short circuit and/or interruption of electrical components:
  - Solenoid valve
  - Flameguard
  - Overheating protection
  - the temperature sensor (overheat protection/water temperature sensor) is unplugged.
- Flame is not expired within 30 seconds after purge cycle (burner motor stops).
- Overheating protection triggered.
- Control device error
- Repeated malfunctions
- Repeated flame interruptions

#### 4.6.1 Heater lock-out release

To release, the switched on heater must be disconnected from the vehicle electrical system as follows.

##### 4.6.1.1 Release a heater lock-out without DTT diagnosis

**NOTE:**

Disconnect the power supply for release, by pulling the plug C is not permissible.

1. Remedy the cause of the heater lock-out.
2. Disconnect the power supply (e.g. by pulling the fuse) for at least 10s.
3. Reconnect power supply.
4. Switch the locked-out heater off and then on again.
5. Repeat steps 2. and 3.
6. Heater is ready for service and starts, if necessary turn it off.

**NOTE:**

If the main switch remains in the on position when disconnecting the power supply, the heater automatically starts after connecting it to the vehicle electrical system. The heater can be switched off during initial cycle.

##### 4.6.1.2 Release the heater lock-out using the DTT diagnosis

1. Connect the heater with the DTT diagnosis and read out the error memory.
2. Remedy the cause of the heater lock-out.
3. Disconnect the power supply (e.g. by pulling the fuse) for at least 10s.
4. Reconnect the heater to the vehicle electrical system.
5. Using the DTT diagnosis, delete the error/error memory.

## 5 Troubleshooting

### 5.1 General



The safety instructions and regulations of Chapter 1 (see 1.6 ) must be observed.

This section describes troubleshooting and error correction for Thermo plus 160, plus 230, plus 300 and plus 350 heaters.

In case of doubt functional connections can be obtained in chapters 3 and 4.

Error detection is usually limited to localizing the faulty component.

The following malfunction causes are not taken into account and should basically always be verified and/or a malfunction due to these reasons should be excluded:

- Corrosion on plugs
- Loose plug connections
- Crimp failures on plugs and/or pins
- Corrosion on cable and fuses
- Corrosion on battery terminals
- Cable insulation damage
- Damage to contacts due to frequent plugging and unplugging

Table 501 General error symptoms

Error symptom	Possible cause
<p><b>Error in the electronics</b></p> <p>Operation indicator does not light and the heater does not function.</p> <p>Fuse F1 triggered.</p> <p>Fuse F2 triggered.</p> <p>Heater is functional, however the operation indicator does not light.</p>	<ul style="list-style-type: none"> <li>• No supply voltage</li> <li>• Fuses</li> <li>• wiring harness with connector C of the control device</li> </ul> <p>Short circuit in the wiring harness to the heater.</p> <p>Short circuit in the circulating pump or the nozzle block preheater (if installed).</p> <p>Operation indicator defective or cables to the operation indicator interrupted or shorted.</p>

**ATTENTION:**

Prior to replacing a fuse, troubleshooting needs to be performed. The heater must be disconnected from the vehicle electrical system (see 5.2).

A properly dimensioned fuse must be inserted (see chapter 6 wiring diagrams).

After each error correction a functional test must be performed in the vehicle.

### 5.2 Disconnecting the heater from the vehicle electrical system

Some troubleshooting procedures require to disconnect the heater from the vehicle electrical system.

**ATTENTION:**

The disconnection from the vehicle electrical system must not be carried out via the plug on the heater (under voltage).

This can be done for example by pulling the fuses F1, F2 and F3 (see wirings in Cha. 6).

### 5.3 General error symptoms

The following table lists possible, general error symptoms.

Table 501 General error symptoms

Error symptom	Possible cause
<p><b>Error in the water system</b></p> <p>Circulating pump does not operate (Aquavent 6000S and Aquavent 6000SC only).</p>	<ul style="list-style-type: none"> <li>• Error mode activated</li> </ul> <p>In case of malfunctions the motor is switched off via the error mode.</p> <p><b>Reactivation of the circulating pump motor</b>                      For this purpose disconnect the power supply for &gt; 2 min (<b>Observe 5.2 !</b>).                      After the power supply is reconnected the motor performs a soft start.</p>
<p>The heater operation stops because the connected heat exchangers (e.g. front box and side wall heater) provide insufficient heat.</p> <p><b>Approximate flow rate determination:</b></p> <p>Flow rate in [l/h] = <math display="block">\frac{\text{Heat flow [kW] according to type plate}}{\text{Temperature difference } \Delta t \text{ in [K] or [}^\circ\text{C] measured on the heater between water inlet and water outlet}} \times 860</math></p>	<p><u>Flow rate too small, because</u></p> <ul style="list-style-type: none"> <li>• Air in the heater, heat exchanger or in system sections</li> <li>• Taps/valves (flow controllers) throttled, contaminated, closed</li> <li>• Contaminations in the system, e.g. filters or at bottlenecks</li> <li>• Circulating pump delivery rate insufficient (air in pump housing)</li> <li>• Insufficient frost protection</li> <li>• System resistance too high (especially high in the cold)</li> <li>• Circulating pump defective</li> <li>• Adapter wiring harness "Valeo" for variants &gt; 85°C defective</li> </ul> <p><u>Heat exchanger provides not enough heat, because</u></p> <ul style="list-style-type: none"> <li>• Air in the heat exchangers and/or system sections</li> <li>• Contaminated heat exchanger surfaces (outside)</li> <li>• Insufficient air entry or air exit</li> <li>• Fan: Insufficient delivery rate / incorrect direction of rotation / resistance too high</li> <li>• Antifreeze content too high</li> </ul>

Table 501 General error symptoms

Error symptom	Possible cause
<p><b>Error in the fuel supply</b></p> <p>No fuel delivery to the heater.</p>	<ul style="list-style-type: none"> <li>• Fuel tank empty</li> <li>• Bent, closed, clogged or leaking lines</li> <li>• Paraffin deposits or frozen water entrapments in fuel lines or lines</li> <li>• Venting opening in tank closed</li> <li>• Fuel lines mixed up</li> <li>• Fuel filter contaminated</li> <li>• Fuel screen (filter) in pump contaminated</li> <li>• Fuel pump defective</li> <li>• Coupling defective</li> <li>• Fuel lines not suitable for vacuum / not vacuum-tight</li> </ul>
<p><b>Error in the combustion</b></p> <p>CO<sub>2</sub> value cannot be adjusted to nominal value. Irregular combustion.</p>	<ul style="list-style-type: none"> <li>• Air bubbles in fuel supply line (leaking fuel supply line)</li> <li>• Fuel filter contaminated or leaking</li> <li>• Fuel integration leaking (suction lift, low pressure in tank), observe installation instruction</li> <li>• Fuel pump defective</li> <li>• Screen (filter) in fuel pump contaminated</li> <li>• O-ring seal on fuel pump ineffective</li> <li>• Atomizer nozzle defective</li> <li>• Combustion air and exhaust lines throttled or closed</li> <li>• Burner motor speed too low</li> <li>• Coupling defective</li> </ul>



## 5.4 Error indication

Depending on the equipment, the error indication can be done by means of an error code or error code text. The error codes and the corresponding error meanings are shown in [Table 502](#).

If the vehicle is equipped with the digital timer, the error code is shown numerically on the digital timer display.

Another option is to display the error code via the operating indicator light or a light that can be connected to pin 9

and ground of connector C via the wiring harness (see [Fig. 601](#)).

After five short signals, the long flashing pulses are counted. The number of long flashing pulses corresponds to the respective error code.

### NOTE:

If there are faults, only a blink code is output when the main switch is switched on.

Furthermore, the error code text can be displayed with the help of the DTT diagnosis.

Table 502 Error code

No. of impulses/ Error code	Error	Error causes
0	Control device error	Control device error
1	No start within safety period	No start within safety period
2	Flame interruption	Flame interruption in burner operation, repeated start unsuccessful
3	Low Voltage / high voltage	High voltage (> 30V [15V]), at least 6 seconds)
		Low Voltage (< 20.5V [10V]), at least 20 seconds)
4	Extraneous light in initial or purge cycle	Extraneous light (flame detector "Bright" in purge cycle 2)
		Extraneous light (flame detector "Bright" prior to ignition)
5	Flame detector defective	Flame detector short circuit
		Flame detector interruption
6	Temperature sensor / overheat protection defective	Temperature sensor short circuit
		Temperature sensor interruption
		Temperature sensor / overheat protection non-plausible
		Overheat protection short circuit
		Overheat protection interruption
7	Solenoid valve defective	Solenoid valve short circuit
		Solenoid valve interruption
8	Combustion air fan motor / nozzle block preheater defective	Combustion air fan motor short circuit
		nozzle block pre-heater short circuit or the wrong one installed
9	Circulating pump defective	Circulating pump short circuit
10	Overheat protection triggered	Overheating T>140°C
11	Electronic ignition unit defective	Electronic ignition unit short circuit
		Electronic ignition unit interruption

Continued on next page

Table 502 Error code

No. of impulses/ Error code	Error	Error causes
12	Heater lock-out	Flame interruption counter threshold exceeded
		Heater lock-out - release required
		Malfunction counter threshold exceeded
13	not used	
14	not used	
15	Revolution signal faulty	Fuel pump defective
		Fan wheel does not turn freely
		wrong coupling used

## 5.5 Error symptoms during functional tests with malfunction code output or diagnosis

### 5.5.1 Error symptom "No start within safety period"

If due to a malfunction the heater unsuccessfully attempted to start eight times in sequence, it will be locked-out. No further start attempts will be tried.

**The heater lock-out overrides the standard fault lock-out.**

The procedure for releasing the heater lock-out can be found in point [4.6.1](#).

The "No start within safety period" error symptom does not always indicate that no ignition took place. This symptom occurs as well, if the heater fails to enter heating operation (heating or auxiliary heating state) after a successful ignition, e.g. in case the fuel supply is interrupted.

### 5.5.2 Error symptom "Flame interruption"

If due to a malfunction a flame interruption occurs during heating operation five times in sequence, the heater will be locked-out.

No further start attempts will be tried.

**The heater lock-out overrides the standard fault lock-out.**

The procedure for releasing the heater lock-out can be found in point [4.6.1](#).

Flame Interruption Counter (FIC):

The error counter flame interruption is set after 40s burning operation without malfunction to 0.

Reaches the FIC the lock-out threshold (standard 5 times), the heater goes into the heater lock-out.

#### NOTE:

After above mentioned error symptoms occur, troubleshooting according to [page 506](#) recommended.

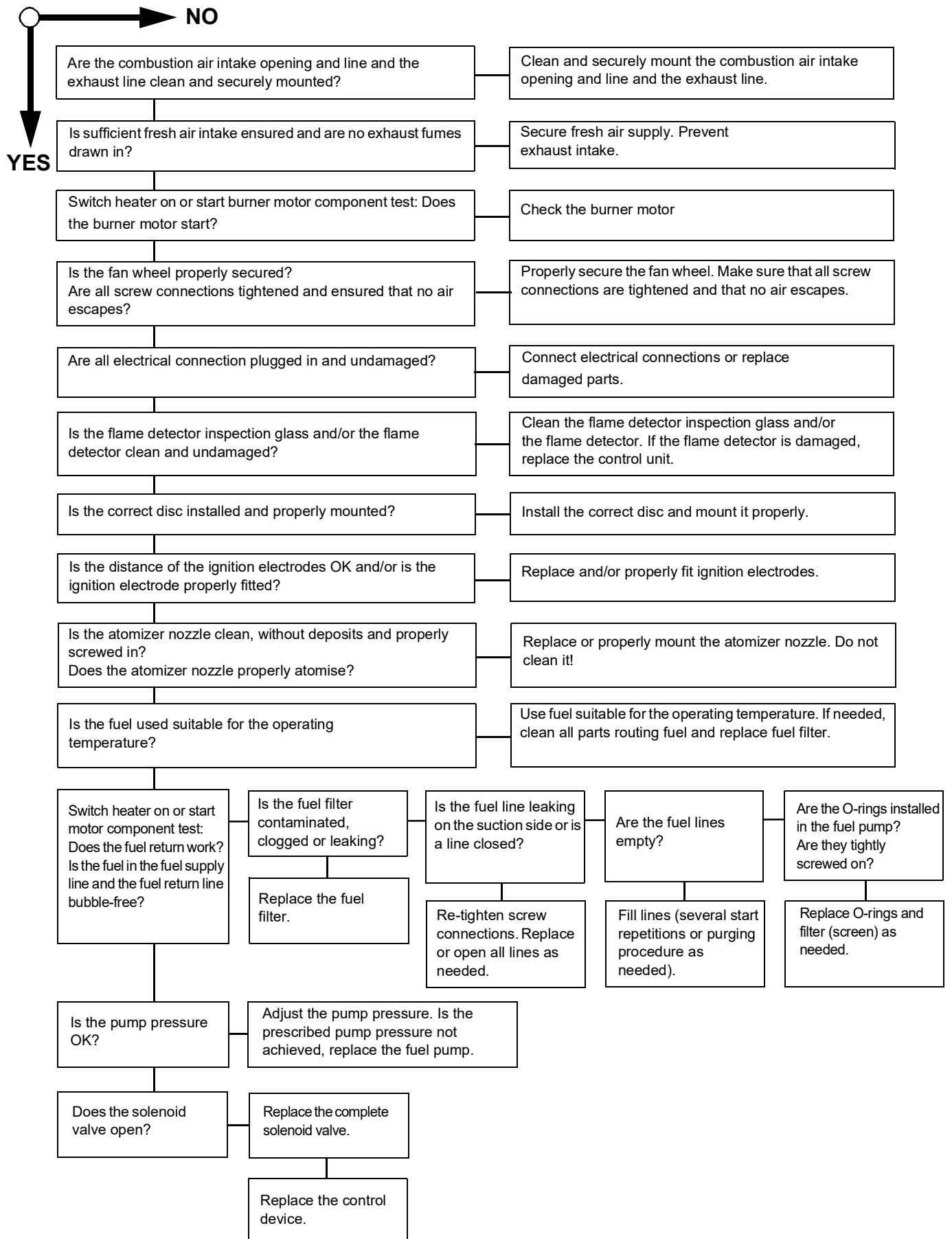

**5.5.3 Error symptom "Low voltage"**

A value is stored in the control unit as smallest "permissible low voltage".

It must be noted that the voltage may be lowered during heater start, and that the "low voltage" threshold may be violated.

Among others this depends on the vehicle electrical system, the temperature of optional components, such as the nozzle block preheater, circulating pumps or heatable filters.

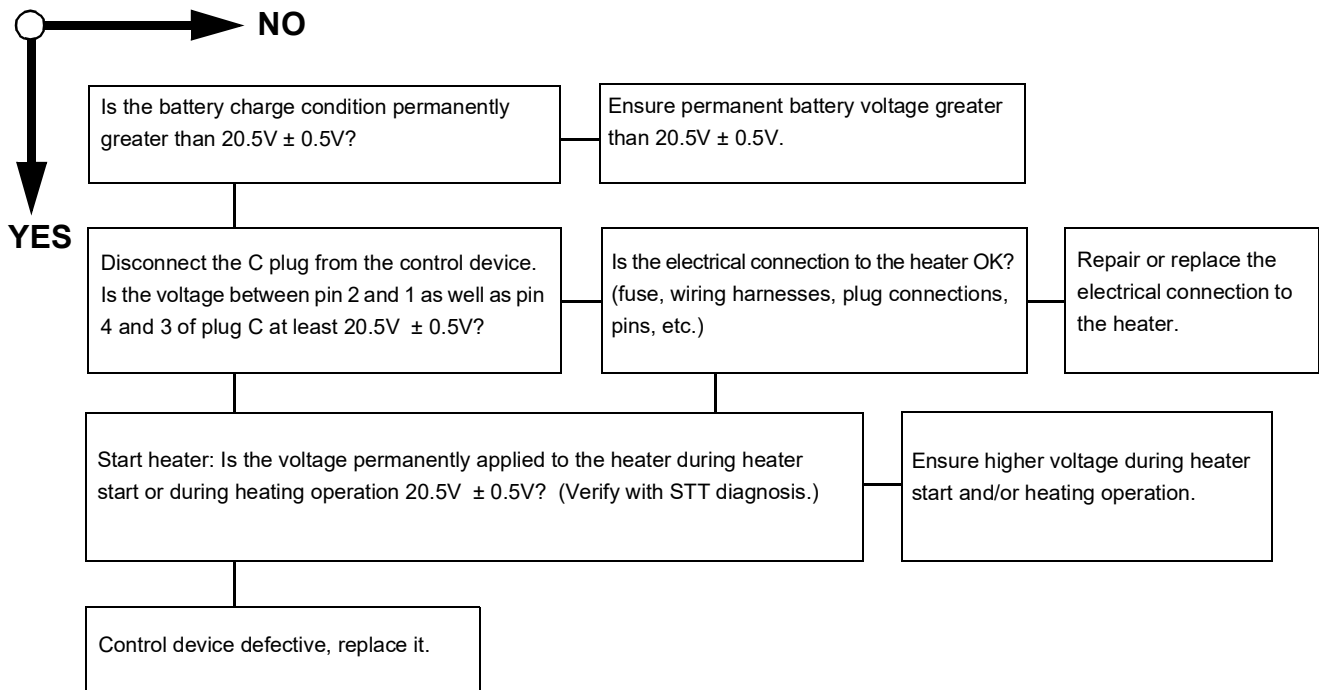

5.5.4 Error symptom "Extraneous light detected prior to ignition or during purge cycle"

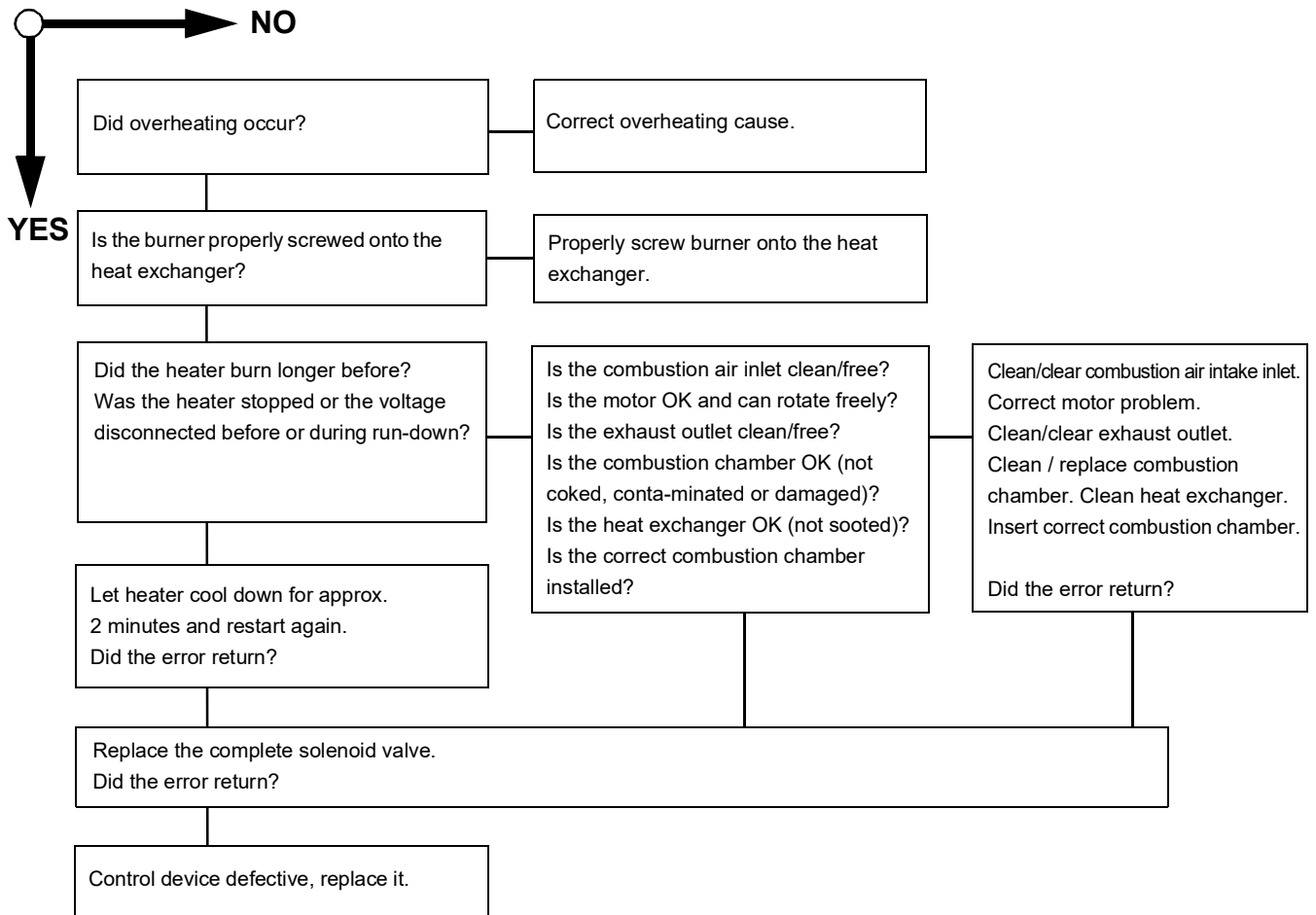

### 5.5.5 Error symptom "Flameguard defective"

The flameguard cannot be replaced. It can only be tested using STT diagnosis.

In case of damage or if the target value cannot be reached, the control device must be replaced as needed.

### 5.5.6 Error symptoms "Temperature sensor / overheating protection defective" and "Overheating"

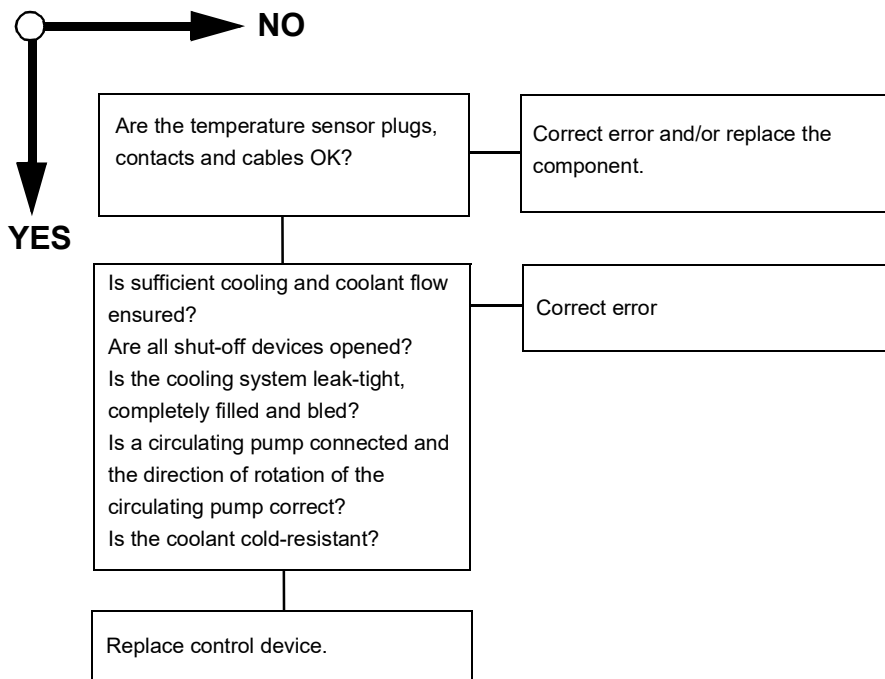

### 5.5.7 Error symptom "Circulating pump defective"

The "Circulating pump defective" error can also be triggered by dry operation of the circulating pump.

## 5.6 Individual component tests

Individual components can basically be tested using visual inspection or manual electrical testing.

In addition, the electrical components burner motor, circulating pump, electronic ignition unit, solenoid valve, nozzle block preheater, operation indicator and flame indicator can be checked using the "Component Test" menu of the STT diagnosis.

The check of the flameguard and the fuel pump pressure is supported by the STT diagnosis.

### 5.6.1 General visual inspection

- Inspect components for damages (cracks, deformation, leaks, discolourations, etc.) and replace as needed.
- Inspect plugs and cables for corrosion, contact and crimp errors and repair as needed.
- Check plug contacts for corrosion and tight fit. Repair as needed

### 5.6.2 Heat exchanger visual inspection

- Inspect heat exchanger interior for damage, corrosion, sooting and deposits.
- Inspect heat exchanger for outer damage, corrosion, moisture, deformations, deposits, discolourations, etc.

#### ATTENTION:

**Soot and deposits in the heat exchanger must be removed, as they impact the heat transfer to the coolant.**

**Severe outer deformations may impact coolant flow.**

#### 5.6.2.1 Visual inspection of exhaust outlet and exhaust line

Inspect exhaust outlet and possibly available exhaust line for conditions, tight fit, contamination and deposits.

#### ATTENTION:

**The exhaust gas temperature can reach over 400°C depending on the heating capacity class.**

- The exhaust pipe must end in the open air.
- The exhaust pipe must be sloped down, arising condensate must be able to drain away.
- Because of the temperatures involved, sufficient distance from heat-sensitive or flammable materials must be ensured.
- Outflowing exhaust gas must not be re-sucked in as combustion air.
- The opening of the exhaust pipe must be aligned against the direction of travel and must not become clogged with dirt or snow.
- If the exhaust outlet is under the vehicle floor, blowing straight down, an exhaust gas deflection

is absolutely necessary.

### 5.6.3 Combustion chamber visual inspection

- Remove combustion chamber (see 8.12).
- Inspect swirl plate and combustion chamber head for damage and tight fit.
- Check and remove combustion chamber for scalings and coke deposits as needed.
- Inspect combustion chamber for deformation and moisture.
- Inspect welding seam and combustion chamber for cracks.

#### NOTE:

Cracks in longitudinal direction at the end of the welding seam shorter than 80 mm are permissible.

- After the inspection is completed, reinstall the combustion chamber (siehe 8.12).

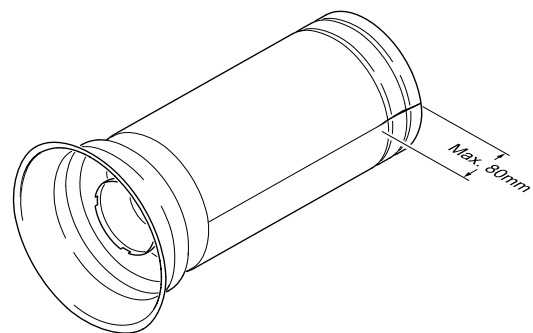

Fig. 501 Combustion chamber

5.6.4 Check of the temperature sensor with integrated overheating protection

 <b>Caution!</b>	<b>Risk of scalds!</b>
---	------------------------

Prior to removing the temperature sensors, the overpressure in the cooling system must be released by opening the cooling lid. Observe the risk of injuries due to increased coolant temperature. Possibly let the heater additionally cool down and have a collecting container ready for discharged coolant.

Check

- Inspect temperature sensor, plug and cable for damage and proper fit.
- Remove temperature sensor (see 8.3).
- Perform the electrical test using a measuring device suitable for resistance measurements.  
The water temperature sensor and the overheating protection should indicate values according to the charts. (Fig. 503 and Fig. 504).  
Preferably the resistance should be measured at an approx. consistent temperature of 20° C and approx. 100° C (immerse sensor up to the copper gasket ring into boiling water).  
Prior to reading the value, the sensor should be exposed to the temperature for approx. 20 seconds.  
A measurement tolerance of +/- 5° C under workshop conditions is permitted.
- Reinstall temperature sensor (see 8.3).

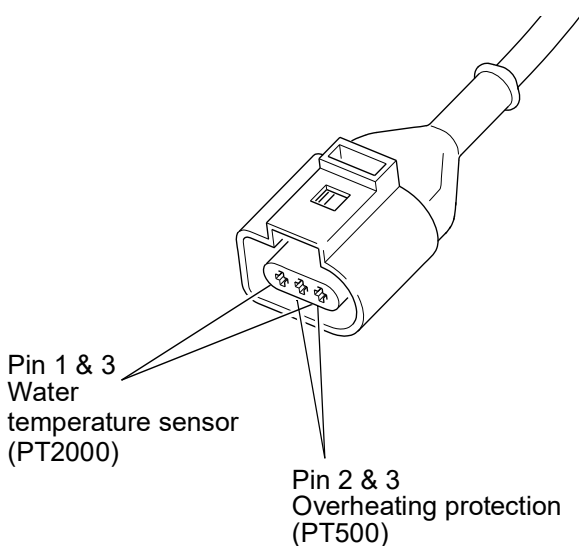

Fig. 502 Temperature sensor connector

Resistance vs. temperature charts

Diagramm Widerstand über Temperatur

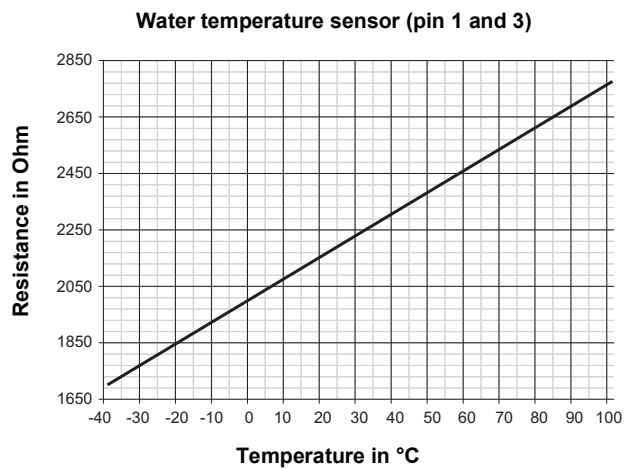

Fig. 503

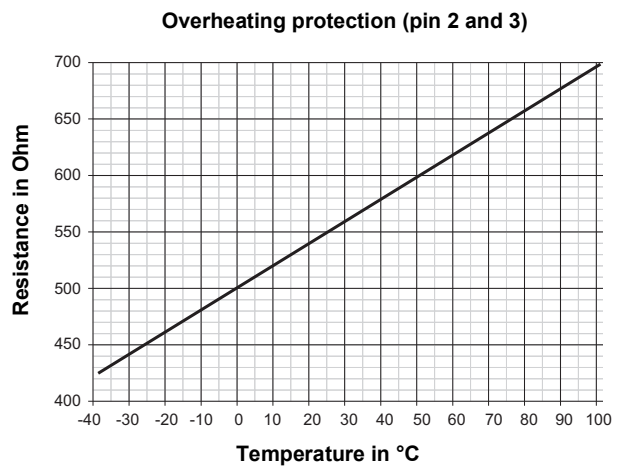

Fig. 504



### 5.6.5 Fan and combustion air intake line visual inspection

- Inspect a possibly available combustion air intake line for contamination, condition and deposits.
- Remove hood (see 8.4).
- Inspect fan channels for contamination and deposits.
- Inspect fan and motor shaft mount for cracks, stress marks and deformations.
- Check cover plate for tight fit.
- Check circlip for proper fit.
- Install hood (see 8.4).

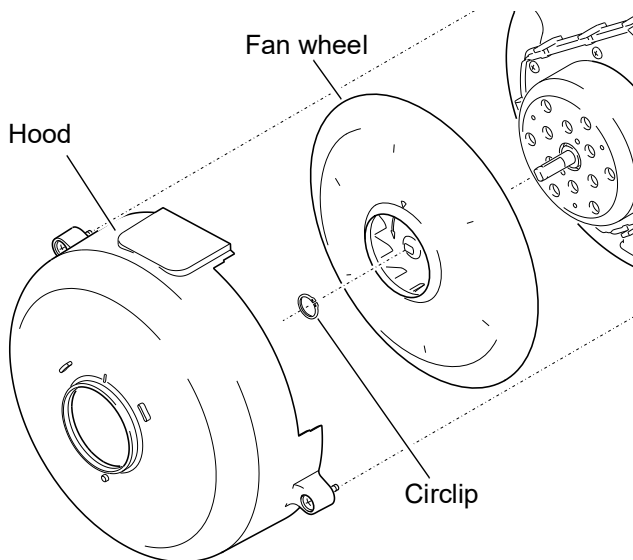

Fig. 505

### 5.6.6 Burner motor inspection

#### NOTE:

It is possible to test the burner motor using the Component Test menu of the STT diagnosis.

#### Inspection using the STT diagnosis

- Disconnect the heater from the vehicle electrical system (**Observe 5.2 !**).
- Connect the test plug instead of the temperature sensor plug to the control device.  
Reconnect the heater with the vehicle electrical system.

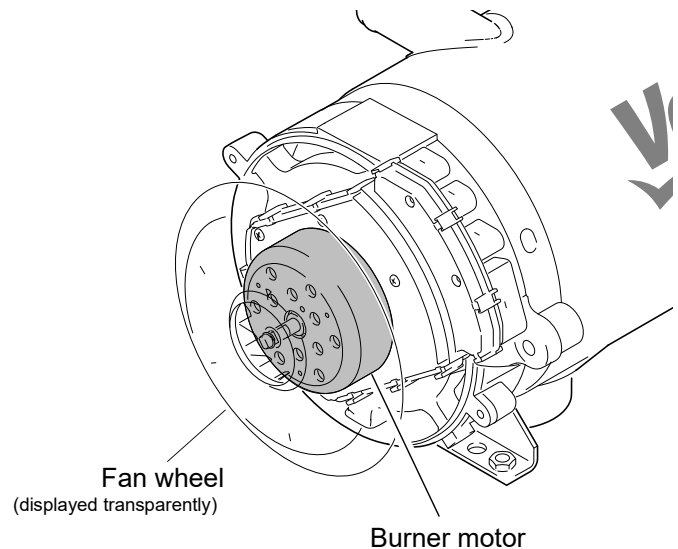

Fig. 506

- Connect the STT diagnosis to the heater.
- Start STT diagnosis, establish connection to the heater and open the Component Test menu.
- Select the motor in the Component Test menu. Enter target speed and runtime. Next start the component test.
- Compare the real motor speed with the target motor speed given by the STT diagnosis.
- After the test is completed, exit STT diagnosis as needed.
- Disconnect the heater from the vehicle electrical system.
- Disconnect the test plug and reconnect the temperature sensor plug.
- Reconnect the heater to the vehicle electrical system.

### 5.6.7 Electronic ignition unit inspection

#### NOTE:

It is possible to manually test the functionality of the electronic ignition unit, and using the Component Test menu of the STT diagnosis.

It can only be verified by visual inspection of the ignition electrode, whether the ignition spark jumps over to the ignition electrode.



**High voltage:** The voltage received by the ignition electrode is  $>13,000$  Volt.

**During operation or testing of the electronic ignition unit, the ignition electrode may not be contacted by persons or items.**

#### ATTENTION:

**Do not test or apply voltage to the electronic ignition unit without an ignition electrode.**

Inspect the electronic ignition unit for housing and end cover damage.

No mechanical damage may be caused or be present on housing and end cover.

#### Inspection using the STT diagnosis

- Remove the burner head (see 8.2).
- Connect the test plug instead of the temperature sensor plug to the control device.
- Reconnect the heater with the vehicle electrical system.
- Connect the STT diagnosis to the heater.
- Start STT diagnosis, establish connection to the heater and open the Component Test menu.
- Select the electronic ignition unit in the Component Test menu.  
Enter a runtime. Next start the component test.
- Nominal condition: Ignition sparks at the ignition electrode jump over with a rate of 6Hz.
- After the test is completed, exit STT diagnosis as needed.
- Disconnect the heater from the vehicle electrical system (**Observe 5.2 !**).
- Remove test plug.

- Install burner head (see 8.2).

#### Manual functional test when disassembled:

- Remove electronic ignition unit (see 8.6).
- Connect ignition electrode.
- Apply 24V direct voltage according to Fig. 507 (10kOhm on SE input).
- Nominal condition: Ignition sparks at the ignition electrode jump over with a rate of 6Hz.
- After the test is completed, install the electronic ignition unit (see 8.6).

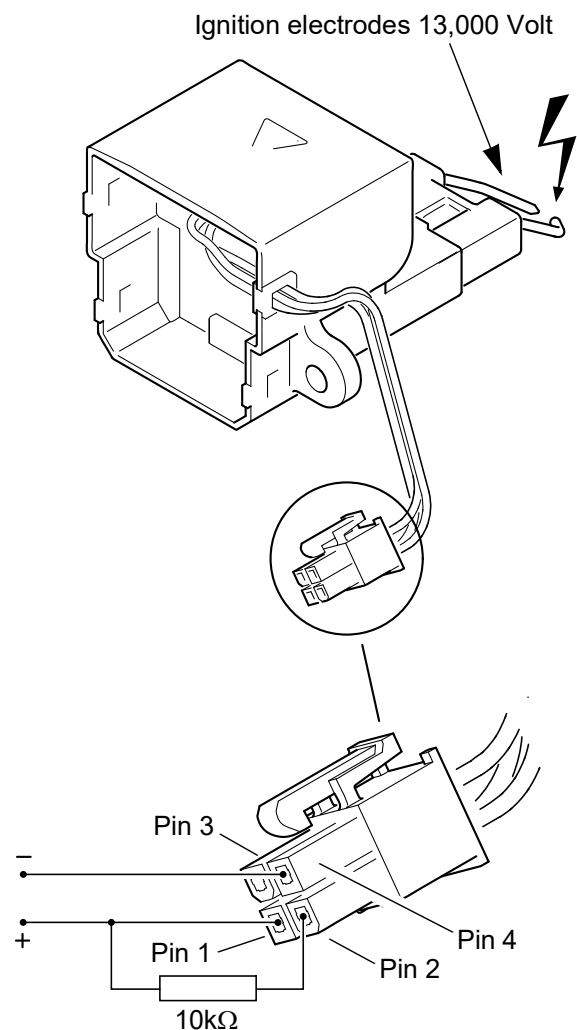

Fig. 507

5.6.8 Ignition electrode inspection

**NOTE:**

The ignition electrode insulation may not be damaged. Ignition electrodes not functioning properly must be replaced.

**ATTENTION:**

Do not damage the electronic ignition unit when removing the ignition electrode.

 <b>Warning!</b>	<b>Risc of electric shock!</b>
---	--------------------------------

**High voltage:** The voltage received by the ignition electrode is >13,000 Volt.  
**During operation or testing of the electronic ignition unit, the ignition electrode may not be contacted by persons or items.**

**Inspection**

- Remove burner head (see 8.2).
- Check distance of the electrode tip to the atomizer nozzle (see Fig. 508).
- Check the distance between the electrodes (see Fig. 508).

**NOTE:**

Gauge 310646Z can be used to check and adjust the ignition electrodes.

- If needed, lift off ignition electrode (3, Fig. 805) from the electronic ignition unit by twisting a screwdriver sideways (see Fig. 804).
- Inspect the ignition electrode insulation for damage.
- Functionality is verified while inspecting the electronic ignition unit.

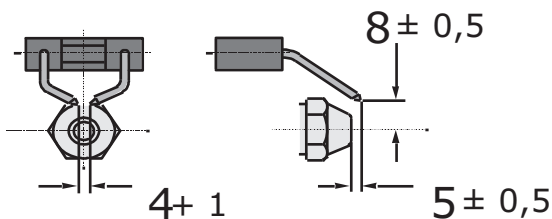

Fig. 508

5.6.9 Flameguard inspection

**NOTE:**

In case of contamination the flameguard lens and the inspection glass in the disc (see Fig. 509) must be cleaned.

The flameguard is permanently integrated into the control device and cannot be replaced.

Functionality is verified using STT diagnosis.

In case of damage or if the target value cannot be reached, the control device must be replaced as needed.

**Inspection**

- Remove burner head (see 8.2).
- Reconnect the heater with the vehicle electrical system.
- Connect the STT diagnosis to the heater.
- Start the STT diagnosis and establish connection to the heater.
- Cover the flameguard lens.
- Check the flameguard voltage displayed on a PC by the STT diagnosis (target value: U = 2.6V...3.3V).
- Remove the cover from the flameguard lens and illuminate it from close distance using a bright lamp.
- Check the flameguard voltage displayed on a PC by the STT diagnosis (target value: U = 0.5V...1.6V).
- After the test is completed, exit STT diagnosis as needed.
- Disconnect the heater from the vehicle electrical system.
- Install burner head (see 8.2).

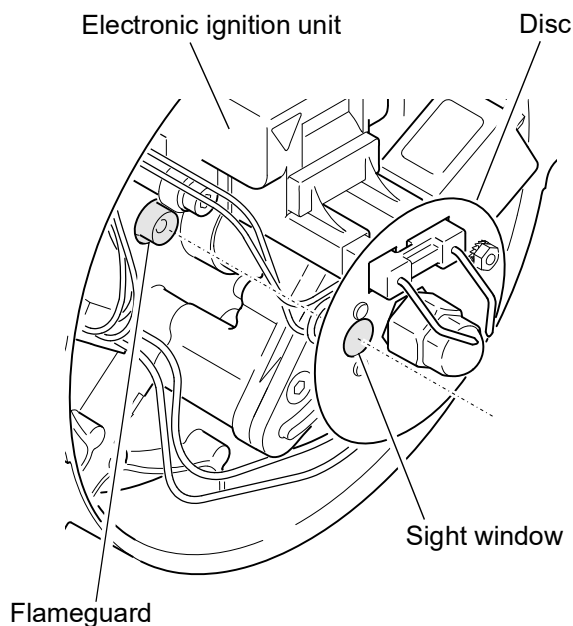

Fig. 509

### 5.6.10 Fuel pump inspection

**ATTENTION:**

The pump pressure of the fuel pump is adjusted to a defined value in the factory.  
It is permitted to readjust the pump pressure.

According to the manufacturer's specifications the fuel pump and fuel hoses must be replaced after 5 years.

**NOTE:**

If bio diesel or FAME is used, the fuel pump and fuel lines must be replaced according to the latest technical information / notification.



The ignition electrode must be removed during the pump pressure check.

**NOTE:**

The fuel pump pressure can be checked while the burner head is removed, using the Component Test menu of STT diagnosis.

A pressure test gauge with a display range from 0 to 15 bar as well as a bleeding feature is required (Fig. 511). The pressure test gauge can be obtained from a Valeo Service Center or a distribution partner.

The following inspections should be performed prior to testing the pump pressure:

- Is the CO<sub>2</sub> content properly adjusted?
- Is the fuel temperature 15...25°C?
- Are available check valves in the fuel supply and return line opened?
- Was the fuel filter in the fuel supply line replaced?
- Are the filters (screens) in the pump inlet clean?
- Is the fuel delivered without bubbles?
- 

Attach a transparent hose for testing.

**Inspection using the STT diagnosis**

- Remove burner head (see 8.2).
- Connect the test plug instead of the temperature sensor plug to the control device.

- Remove ignition electrode (see 8.6).
- Remove fuel nozzle (see 8.11).
- Screw the pressure test gauge into the nozzle block (20 Nm ±2).

**NOTE:**

Exert counter pressure at the hexagon of the fuel pump nozzle block using a tool.

- Reconnect the heater with the vehicle electrical system.
- Connect the STT diagnosis to the heater.
- Start STT diagnosis, establish connection to the heater and open the Component Test menu.
- Select the fuel pump pressure test in the Component Test menu.
- Check the information and follow the instructions provided by STT diagnosis..
- The motor is started using the speed programmed in the control device.
- Open the bleed port at the pressure test gauge until some fuel escapes, collect it e.g. with a cloth. Close the bleed port and read the present pressure at the gauge.
- Compare the actual pressure with the target pressure of 8 +1 bar.

**If the specified pressure cannot be reached, it can be readjusted. For that rotate the adjusting screw (see Fig. 510) max. one revolution. If the prescribed pressure despite readjustment not be achieved or occur leaks, the fuel pump must be replaced.**

- Follow the instructions provided by STT diagnosis.
- After the test is completed, exit the STT diagnosis as needed.
- Disconnect the heater from the vehicle electrical system (**Observe 5.2 !**).
- Remove the test plug.
- Remove the pressure test gauge.

**NOTE:**

Exert counter pressure at the hexagon of the fuel pump nozzle block using a tool.

- Install fuel nozzle (see 8.11).

- Install ignition electrode (see 8.6).
- Install burner head (see 8.2).

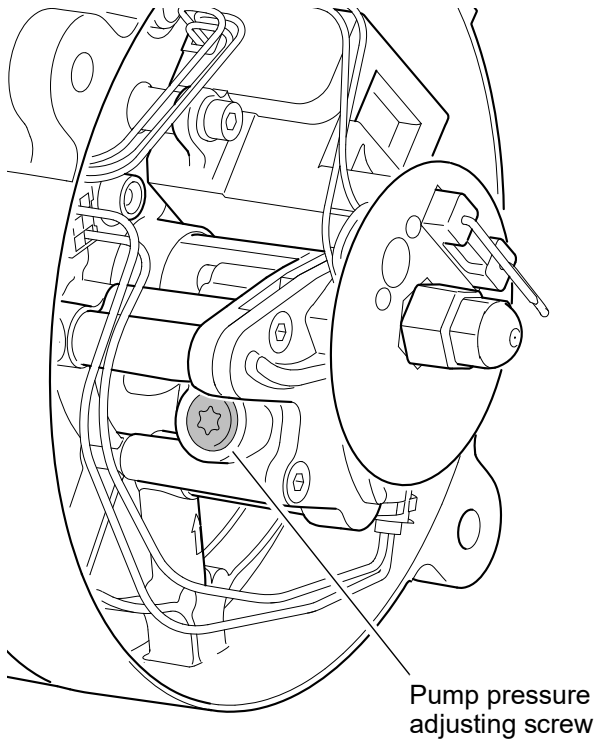

Fig. 510

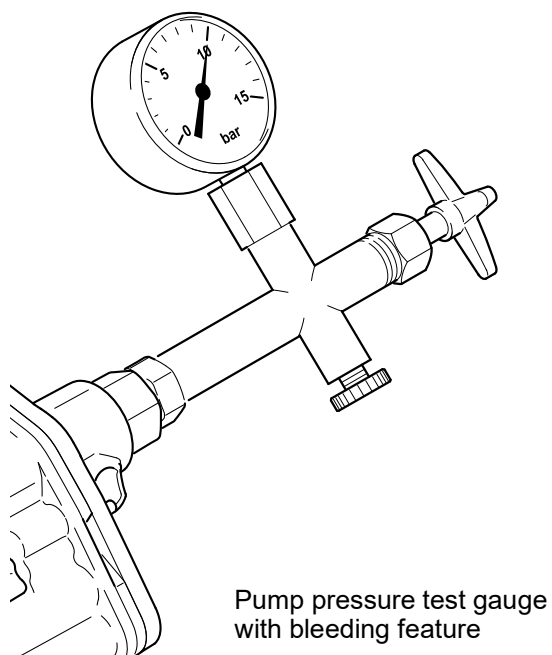

Fig. 511

### 5.6.11 Solenoid valve inspection



**Caution!**

**Risk of burns!**

The coil of the solenoid valve can heat up in switched-on condition.

The solenoid valve must only be completely replaced. In case of replacement or assembly a new gasket ring must be used.

**NOTE:**

Due to system characteristics draining the space between solenoid valve and nozzle may cause fuel dripping from the atomizer nozzle for a short period of time.

A leaking valve seat of the solenoid valve can be indicated by smoke development in the heater during the purge cycle. Fuel drips from the atomizer nozzle. A not closing solenoid valve can lead to a heater shut-down during purge cycle and a heater lock-out.

It is possible to manually test the electrical functionality of the solenoid valve, and using the Component Test menu of the STT diagnosis.

#### Inspection using the STT diagnosis

- Remove the burner head (see 8.2).
- Connect the test plug instead of the temperature sensor plug to the control device.
- Reconnect the heater with the vehicle electrical system.
- Connect the STT diagnosis to the heater.
- Start STT diagnosis, establish connection to the heater and open the Component Test menu.
- Select and start the solenoid valve in the Component Test menu.
- The solenoid valve must audibly open.
- After the test is completed, exit STT diagnosis as needed.
- Disconnect the heater from the vehicle electrical system (**Observe 5.2 !**).
- Remove the test plug.
- Install burner head (see 8.2).

**Manual inspection**

- Remove burner head (see 8.2).
- Disconnect the solenoid valve plug from the control device.
- Check the electrical functionality by applying direct voltage:
  - Opening voltage: starting at 17.0 Volt
  - Power consumption at 24V and 20°C: 9 Watt
  - Nominal current at 24V: 0.37 Ampere

**The solenoid valve must audibly open, when voltage is applied.**

- Connect the solenoid valve plug to the control device.
- Install burner head (see 8.2).

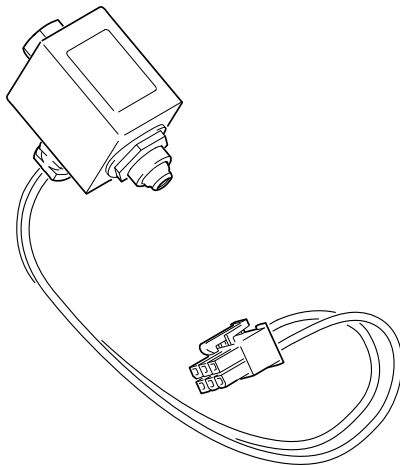

Fig. 512 Solenoid valve

**5.6.12 Nozzle block preheater inspection**

The heating element of the nozzle block preheater can heat up during inspection. Do not pull heating element out of the nozzle holder during inspection.

**NOTE:**

At a temperature of  $< 5^{\circ}\text{C}$  the thermostat switches the heating element on (see 3.1.5).

The power consumption of the heating element at 24V is approx. 80W.

**Inspection using the STT diagnosis**

- Remove burner head (see 8.2).
- Connect the test plug instead of the temperature sensor plug to the control device.
- Reconnect the heater with the vehicle electrical system.
- Connect the STT diagnosis to the heater.
- Start STT diagnosis, establish connection to the heater and open the Component Test menu.
- Select the nozzle block preheater in the Component Test menu, enter a runtime and then start the component test.
 

In order to heat up the heating element, a temperature below  $5^{\circ}\text{C}$  must be applied to the thermostat. If necessary, the thermostat must be cooled below  $5^{\circ}\text{C}$  for the test.

Caution: At the same time, when a circulating pump is connected, it is started too.

**Nominal condition: The heating element warms up.**

- After the test is completed, exit STT diagnosis as needed.
- Disconnect the heater from the vehicle electrical system (**Observe 5.2 !**).
- Remove the test plug.
- Install burner head (see 8.2).

**Manual inspection**

- Remove burner head (see 8.2).
- Disconnect the nozzle block preheater plug from the control unit.
- If necessary, remove the nozzle block preheater.
- Bypass the thermostat or if necessary cool it down below  $5^{\circ}\text{C}$ .
- Connect an ohmmeter to the connector.

**Resistance is max. 8 Ohm**

- If necessary install the nozzle block preheater.
- Plug the nozzle block preheater into the control device.
- Install the burner head (see 8.2).

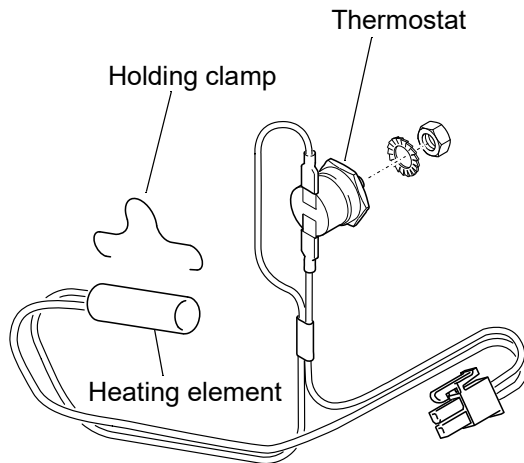

Fig. 513 Nozzle block preheater

### 5.6.13 Circulating pump inspection

#### ATTENTION:

The circulating pump fuse may never be pulled, while the pump is running.

#### Inspection using the STT diagnosis

- Check electrical connections as well as the leak-tightness of the cooling system.
- Disconnect the heater from the vehicle electrical system (**Observe 5.2 !**).
- Connect the test plug instead of the temperature sensor plug to the control device.
- Connect the heater to the vehicle electrical system.
- Connect the STT diagnosis to the heater.
- Start STT diagnosis, establish connection to the heater and open the Component Test menu.
- Select the circulating pump in the Component Test menu and start the component test.
- After the test is completed, exit STT diagnosis as needed.
- Disconnect the heater from the vehicle electrical system (**Observe 5.2 !**).
- Disconnect the test plug and reconnect the temperature sensor plug.
- Reconnect the heater to the vehicle electrical system.

## 6 Wiring diagrams

### 6.1 General

The following figures represent heater connection options to the vehicle electrical system.

The minimum cable cross-sections indicated in the table must be applied.

Cable length <7.5m	Cable length 7.5 - 15m
0.75 mm <sup>2</sup>	1.5 mm <sup>2</sup>
2.5 mm <sup>2</sup>	4.0 mm <sup>2</sup> *

\* The cable cross-section is to be reduced in front of the heater to 2.5 mm<sup>2</sup>.

**NOTE:**

The vehicle type fuses are to be installed so, that their ambient temperature do not exceed 60°C.



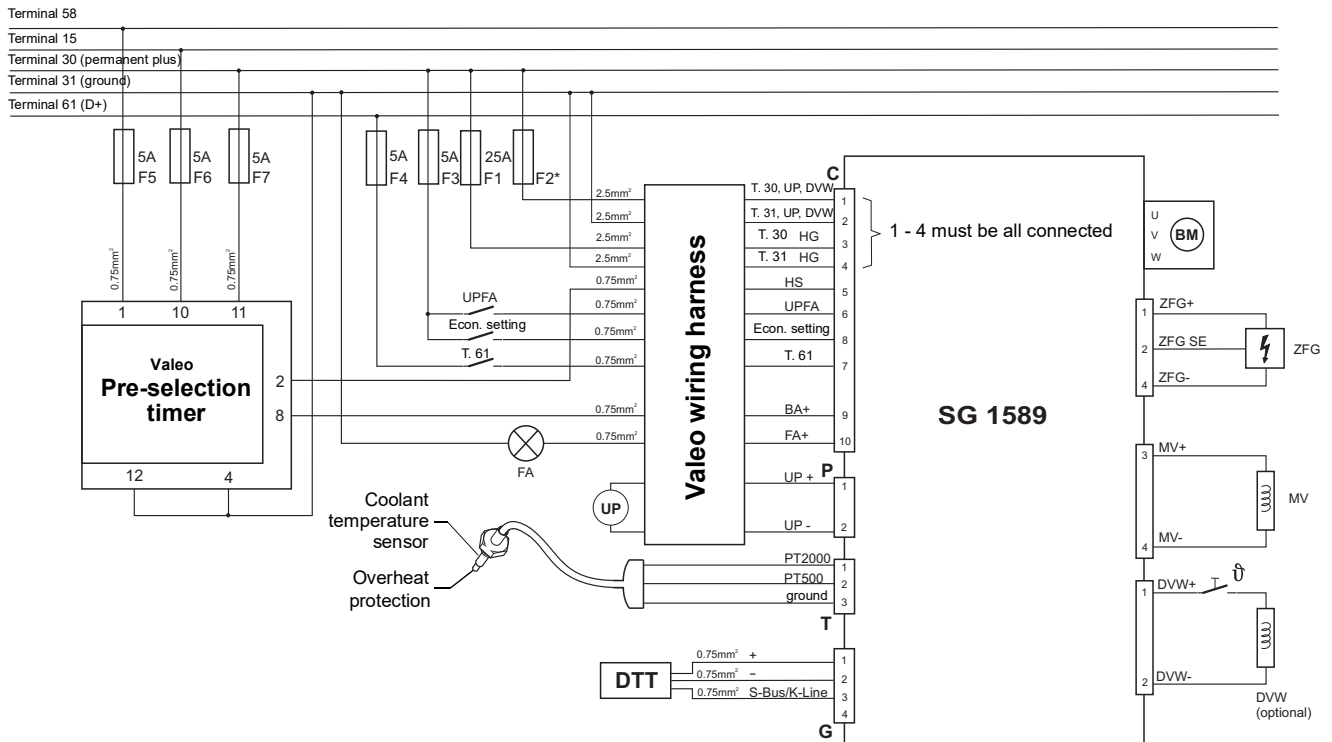

\* Value acc. to UP, max. 25A, min. 7.5A because of DVW

Fig. 601 System wiring diagram for the heater Thermo plus with pre-selection timer, legend see page 603

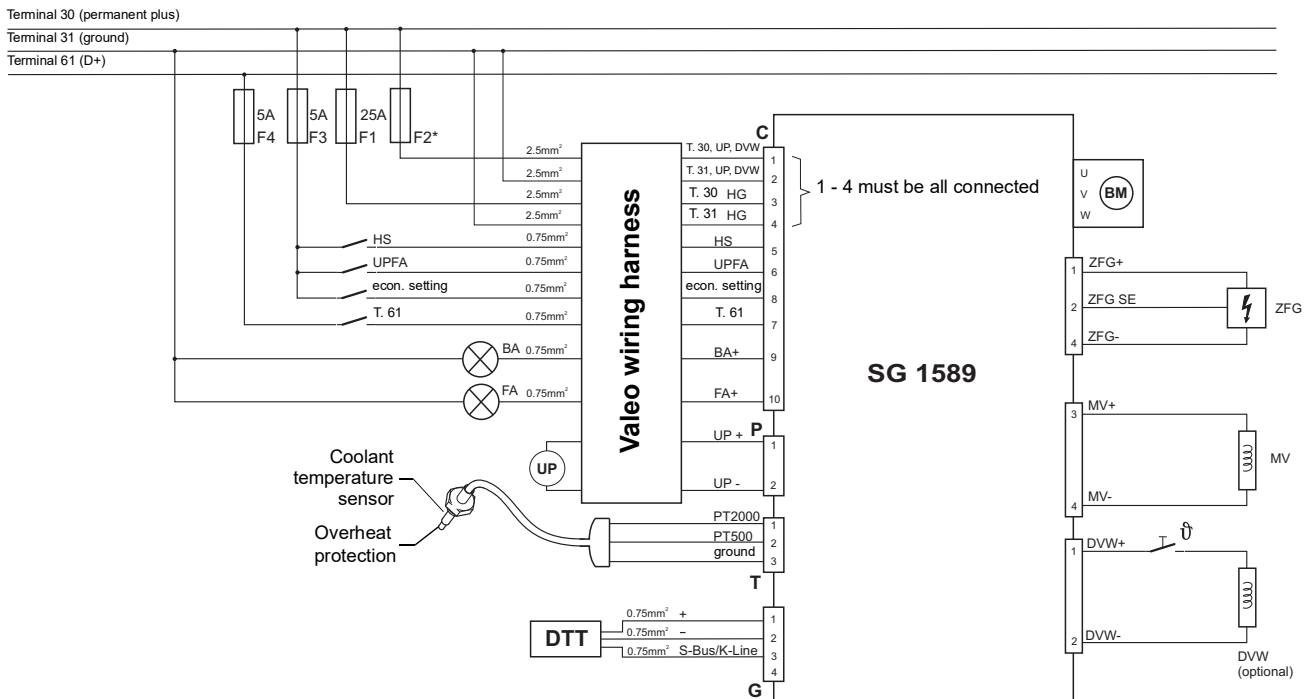

\* Value acc. to UP, max. 25A, min. 7.5A because of DVW

Fig. 602 System wiring diagram for the heater Thermo plus with switch, legend see page 603

Position	Designation
BA	Operation indicator max. 1x5W or 2x2W
FA	Flame indicator
UP	Circulation pump
STT	Spheros Thermo Test (diagnostic tool)
F1, F2*	Car flat-type fuse 25A acc. to DIN 72581 part 3 or ISO 8820-3
F3 - F7	Car flat-type fuse 5A acc. to DIN 72581 part 3 or ISO 8820-3
HS	Main switch
UPFA	Circulating pump external control
Spar	Economic setting
DVW	Nozzle preheater (in the heater)
ZFG	Electronic ignition unit (in the heater)
MV	Solenoid valve (in the heater)
BM	Combustion air motor (in the heater)

Legend for wiring diagrams

\* Note for F2: The max. possible for the design value is shown.  
The fuse is to be adapt under circumstances acc. to the smaller cable cross section of the connected circulating pump.

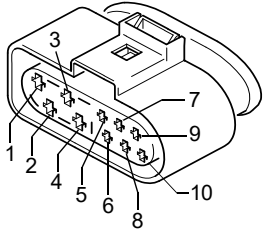
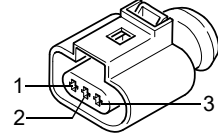
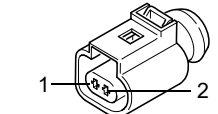
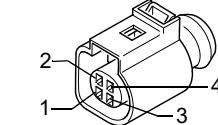
Connector	Description	
<b>C</b>	<b>To vehicle (Power)</b>	
C1	KL. 30 (+), UP (DVW)	
C2	KL. 31 (-), UP (DVW)	
C3	KL. 30 (+), HG	
C4	KL. 31 (-), HG	
C5	Main switch	
C6	UPFA	
C7	Terminal 61 (D+)	
C8	Economic setting (Spar)	
C9	Operation indicator +	
C10	Flame indicator +	
<b>T</b>	<b>Temperature sensors</b>	
T1	Temp. sensor PT2000 +	
T2	Overheat protection PT500 +	
T3	Ground	
<b>P</b>	<b>Circulating pump</b>	
P1	Circulating pump +	
P2	Circulating pump -	
<b>G</b>	<b>Gateway/Diagnosis</b>	
G1	Terminal 30	
G2	Ground	
G3	S Bus/K-Line	
G4	--	

Connector pin assignment

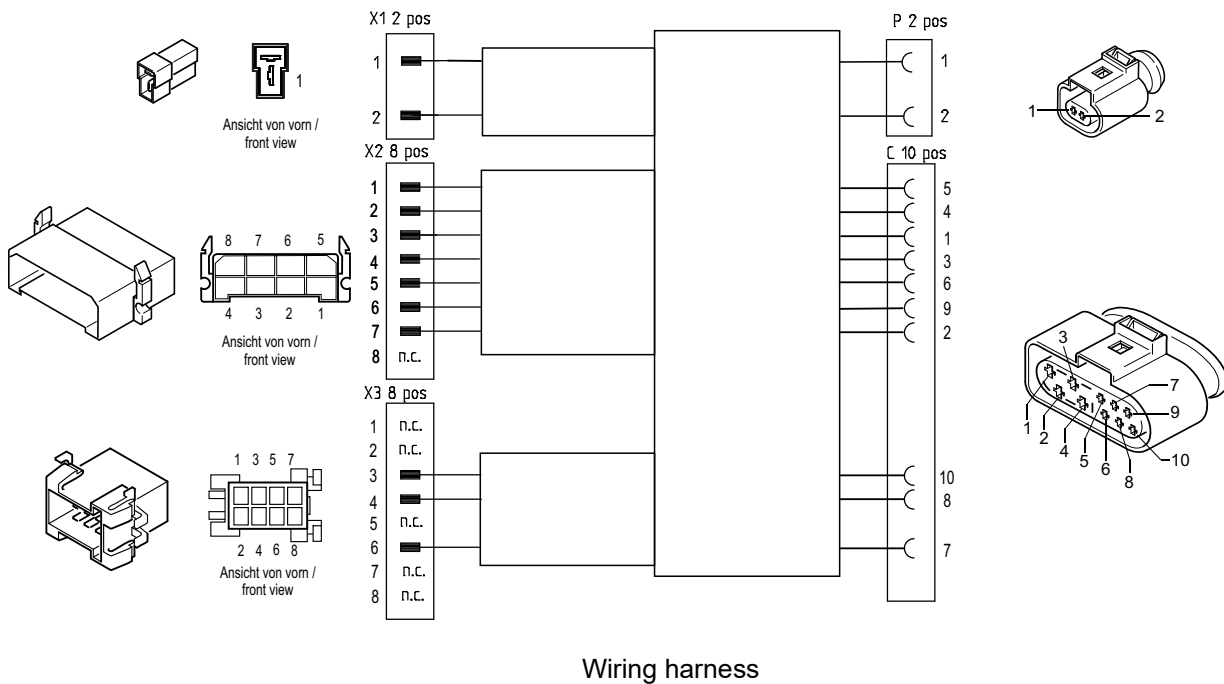

Fig. 603 Wiring harness 11123331\_ - connector and pin assignment

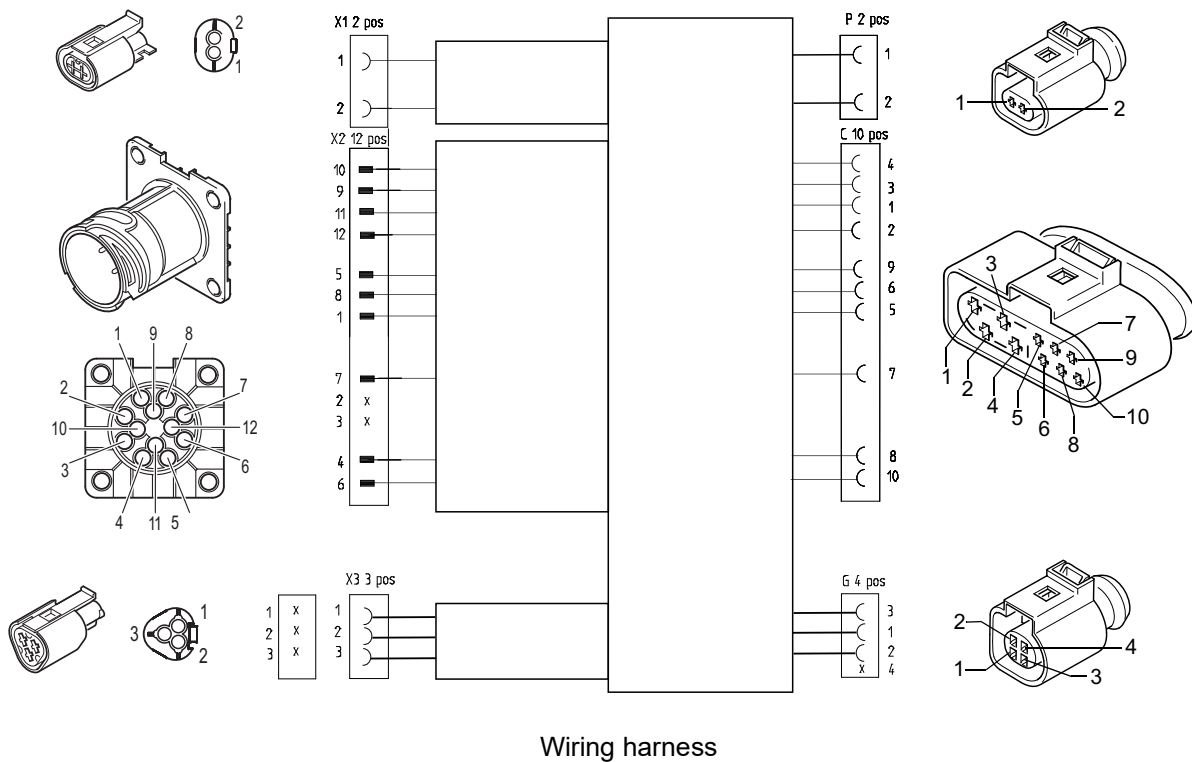

Fig. 604 Wiring harness 11123507\_ - connector and pin assignment

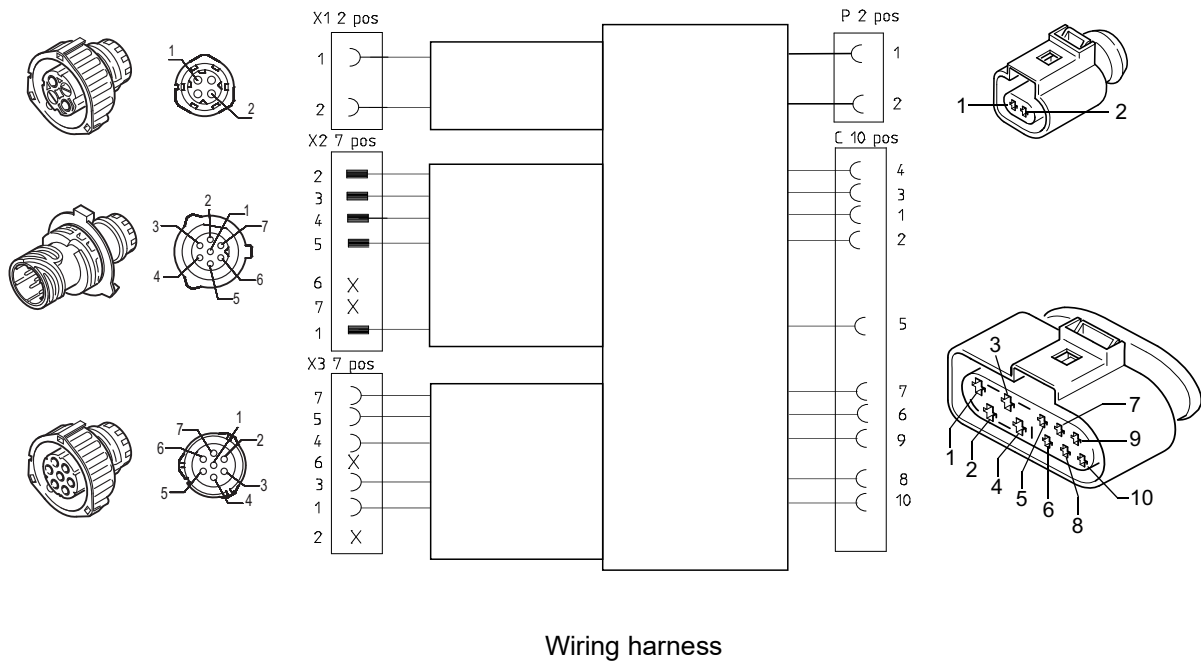

Fig. 605 Wiring harness 11123530\_ - connector and pin assignment

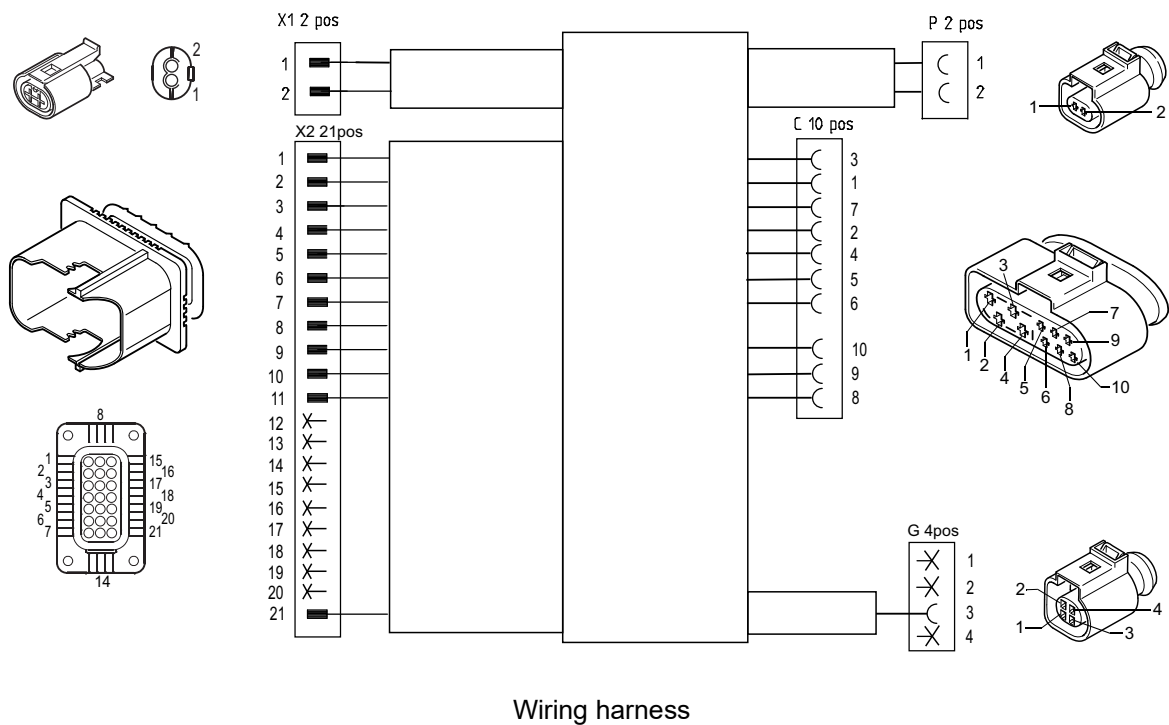

Fig. 606 Wiring harness 11141003\_ - connector and pin assignment

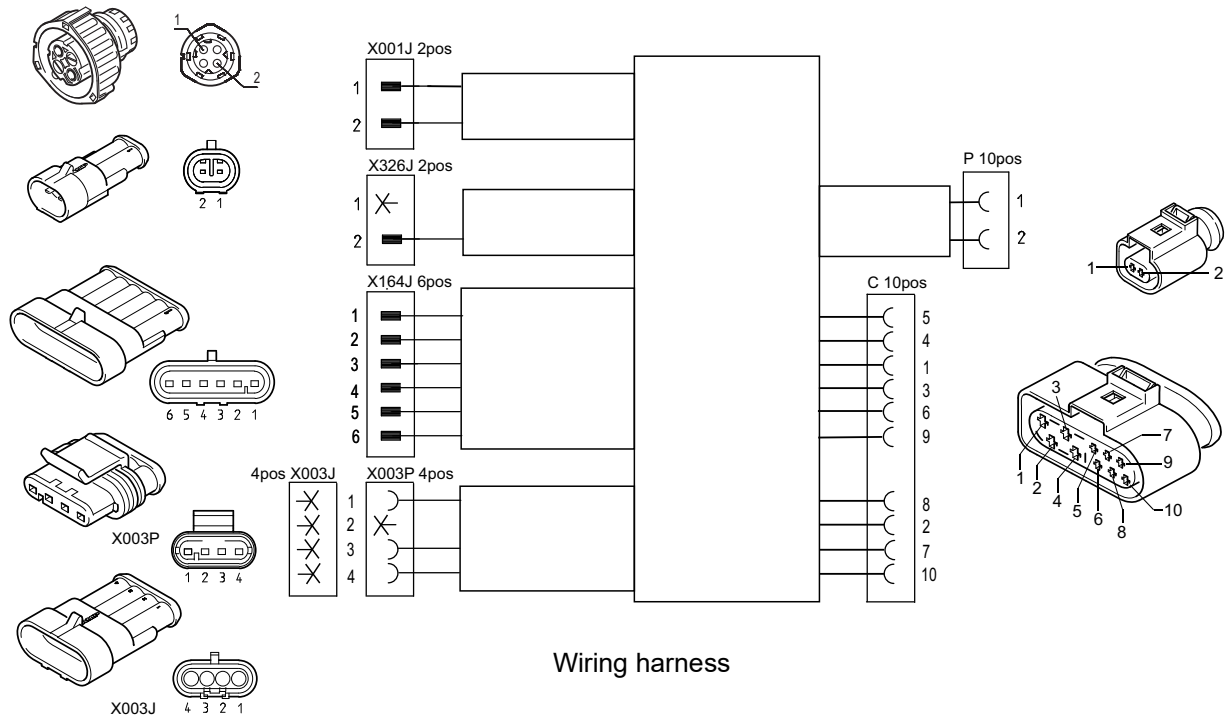

Fig. 607 Wiring harness 11125777\_ - connector and pin assignment

## 7 Servicing

### 7.1 General



**Warning!**

**Danger to life and health!**

The safety hints and regulations in Chapter 1 (see 1.6) must be adhered.

#### 7.1.1 Heater servicing

For risk of overheating, the battery current may not be disconnected, while the heater is operating or in purge cycle.

Make sure that the circulating pump is running while the heater is switched on for tests/inspections.

### 7.2 Servicing

In order to ensure long-term functional reliability, the following maintenance activities should be performed on the heater.

#### 7.2.1 Periodic heater maintenance

Scope and intervals of the periodic maintenance of the heater can be found in [Appendix A](#) of this Workshop Manual.

#### 7.2.2 CO<sub>2</sub> content adjustment

A modification of the factory-adjusted burner motor speed and thus of the exhaust CO<sub>2</sub> content is permitted.

That can be achieved by the readjustment of the burner motor speed by means of the STT diagnosis.

An exhaust measurement device (CO<sub>2</sub> measurement device) is necessary for the adjustment.

The exhaust CO<sub>2</sub> content must be measured and the combustion air volume may have to be adjusted:

- after burner repairs.
- in case of combustion irregularities.
- in case of heavy sooting of the heat exchanger or other components during a functional test.
- after atomizer nozzle replacement.
- if heater is mainly operated above 1500 m.
- When using applications other than the intake grid (20819\_), the splash guard (20818\_) or the exhaust pipe with gas deflection (132756\_) and with all combustion air intake or exhaust applications that are not genuine Valeo parts.

The STT diagnosis sequence defines the CO<sub>2</sub> content adjustment procedure.

**Within the scope of the adjustment, the motor speed must be changed in such a way, that the required CO<sub>2</sub> content in the exhaust gas is established (ref. to [Table 201 in 2 Technical Data](#)).**

#### Adjustment procedure

- Connect the STT diagnosis to the heater.
- Switch the heater on.

#### NOTE:

The exhaust should not be measured directly at the exhaust outlet of the heat exchanger, as this may cause inaccuracies.

Exhaust fumes should be sampled from the exhaust pipe in a distance of 350 mm after the heat exchanger. The exhaust fume temperature should be measured at the same location.

Increased exhaust temperature may indicate a sooted heat exchanger (see [5.6.2](#))

- After a combustion period of approx. 3 min. measure the CO<sub>2</sub> content in the exhaust and compare it to the target value (ref. to [Table 201 in 2 Technical Data](#)).
- Determine smoke number as needed: Target value according to Bacharach: ≤ 4.
- Start STT diagnosis, establish connection to the heater and open the Calibration menu.
- Obtain the next steps from STT diagnosis. Adjust the burner motor speed using STT diagnosis to achieve the target value for the CO<sub>2</sub> content.  
A speed increase results in a reduction of the CO<sub>2</sub> content and vice versa.

#### NOTE:

An upper and lower speed limiting value is stored in the control device. This should prevent incorrect adjustments during maintenance/service.

STT diagnosis displays the speed limiting values.

The CO<sub>2</sub> content depends on the fuel (viscosity) and the height above sea level (increase by approx. 0.1 Vol-% per 100 m height increase).

In the case that the CO<sub>2</sub> content cannot be properly adjusted, proceed as follows:

- Inspect burner head on the air side for damage and replace damaged parts as needed.
- Inspect suction / exhaust gas applications for damages and free cross-section.
- Inspect fuel filter for contamination and replace as needed.
- Inspect fuel pump filter (screen) for contamination and replace as needed.
- Replace fuel nozzle.
- Check the fuel pump pressure acc. to para. [5.6.10](#) and readjust as necessary or replace the fuel pump.

## 8 Burner head, components and heater removal and installation

### 8.1 General



The safety hints and regulations in Chapter 1 (see 1.6) must be adhered.

**ATTENTION:**

Prior to disassembling components the heater must be disconnected from the vehicle electrical system (Observe 5.2 !).

**ATTENTION:**

Sealing elements between disassembled components must be principally discarded and replaced. This does not apply to the temperature sensor gasket ring, as it is permanently attached. Screws with coated threads must be discarded and replaced.

It is permitted to remove components from the heater, while the heater is installed in the vehicle, assuming that sufficient space is available and no components will be damaged.

**NOTE:**

If components are disassembled to a degree not covered in this workshop manual, any warranty claim shall be voided.  
Only genuine Valeo spare parts should be used.

In the figures of the procedures following icon is used:



Symbol tightening torque:  
Features in graphics parts (e.g. nuts, bolts) that are to be mounted with a specific tightening torque. The values for the tightening torque are at the symbol and are binding.

## 8.2 Burner head removal and installation

### Burner head removal

1. Disconnect the heater from the vehicle electrical system (**Observe 5.2 !**).
2. Disconnect the plug for the power supply/control (C).
3. Disconnect the plug for the circulating pump (P).
4. Disconnect the temperature sensor plug (T).
5. If necessary, disconnect the combustion air intake line from the heater.

**NOTE:**

Make sure that any fuel leaking during the following work step is immediately bound and professionally disposed of.

6. Unscrew fuel lines (4, Fig. 801) and seal with blank plugs.
7. Unscrew nuts (2).
8. Remove burner head (1).

**NOTE:**

Do not bent any lines when placing the burner down.

### Burner head installation

1. Bring burner head (1, Fig. 801) in assembly position and ensure center alignment and correct fit.
2. Place nuts (2) and alternately tighten them slightly.
3. Tighten nuts (2) with 7.5 Nm + 1 Nm.
4. If applicable, bolt fuel lines down with  $16 \pm 1$  Nm using a banjo bolt and new gaskets, or slide on fuel lines and secure with hose clamps.
5. If applicable, secure the combustion air intake line to the heater.
6. Connect the temperature sensor plug (T).
7. Connect the plug for the circulating pump (P).
8. Connect the plug for power supply/control (C).
9. Connect the heater with the vehicle electrical system.
10. Bleed the fuel supply system (see 8.15.1).

**ATTENTION:**

The two combination nuts M8, connecting the burner head and the heat exchanger, must be tightened to torque, see Fig. 801, each and additional are to be secured using thread lock.

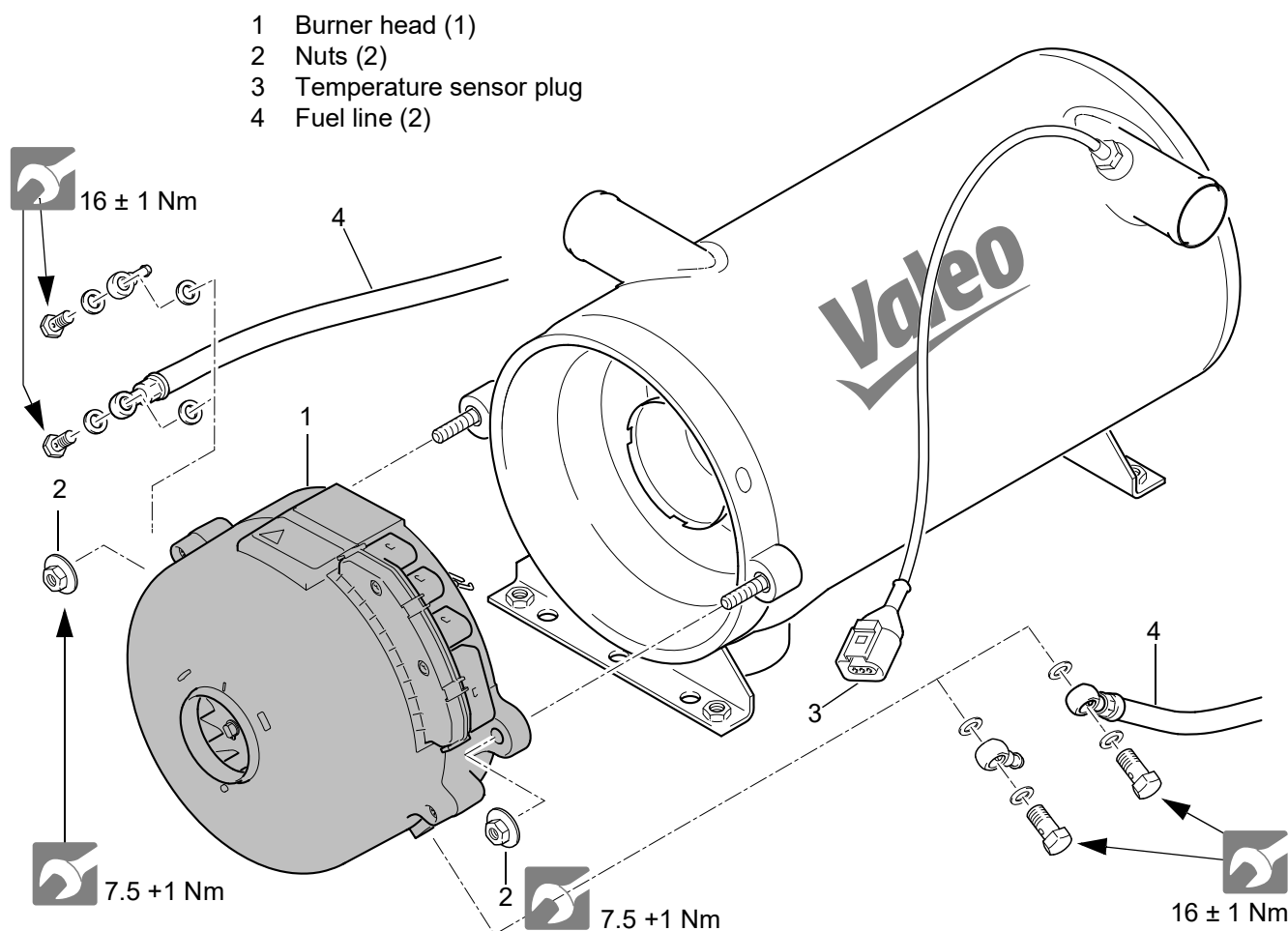

Fig. 801 Burner head removal and installation



### 8.3 Removal and installation of the temperature sensor with integrated overheating protection



**Risk of scalds if coolant temperature is increased.**

#### Removal

1. Disconnect the heater from the vehicle electrical system (**Observe 5.2 !**).
2. Disconnect the temperature sensor plug (3, [Fig. 801](#)).
3. Unscrew and remove the temperature sensor (1, [Fig. 802](#)).

#### Installation

1. Manually screw the temperature sensor (1, [Fig. 802](#)) into the coolant outlet (2).
2. Tighten the temperature sensor (1).
3. Connect the temperature sensor plug (3, [Fig. 801](#)).
4. Connect the heater to the vehicle electrical system.

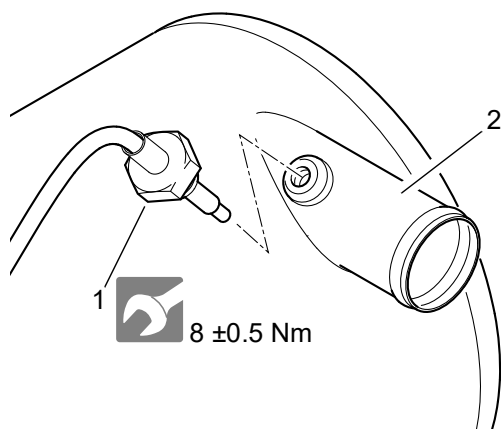

- 1 Temperature sensor
- 2 Coolant outlet

Fig. 802 Temperature sensor removal and installation

### 8.4 Hood removal and installation

#### Removal

1. Disconnect the heater from the vehicle electrical system (**Observe 5.2 !**).
2. Loosen screws (2, [Fig. 803](#)).
3. Remove hood (1).

#### Installation

1. Place hood (1, [Fig. 803](#)) in assembly position. Ensure centre alignment and proper fit.
2. Turn in the screws (2) and tighten them.
3. Connect the heater to the vehicle electrical system.

### 8.5 Fan wheel removal and installation

#### NOTE:

For replacement of the combustion air fan wheel the burner head does not need to be removed.

#### ATTENTION:

**The shaft circlip must always be replaced, after removal. When installing, do not overstretch the shaft circlip.**

#### Removal

1. Remove hood (see [8.4](#)).
2. Remove the shaft circlip (3, [Fig. 803](#)) from the motor shaft using suitable pliers.
3. Remove fan wheel (4) from motor shaft.

#### Installation

1. Put the fan wheel (4) onto the motor shaft.
2. Install the circlip (3) onto the motor shaft using suitable pliers.
8. Install hood (see [8.4](#)).

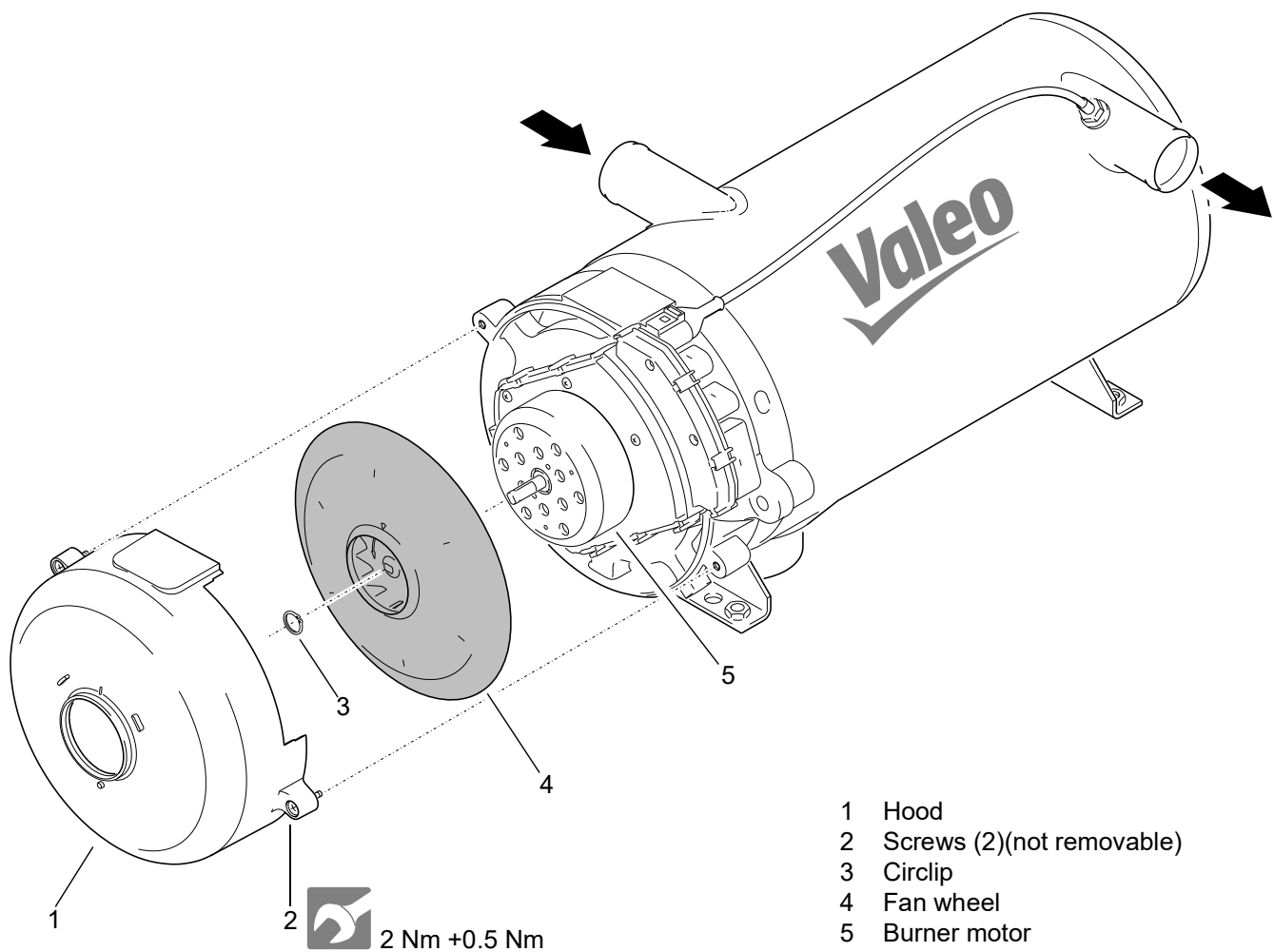

Fig. 803 Fan wheel removal and installation

## 8.6 Electronic ignition unit and ignition electrode removal and installation

### Removal

1. Remove burner head (see 8.2).
2. Lift off ignition electrode from the electronic ignition unit by twisting a screwdriver sideways (see Fig. 804) and remove it.
3. Remove the disc (3) from the nozzle holder.
4. Disconnect the electronic ignition unit plug from the control device.
5. Remove the combination screws (4).
6. Pull electronic ignition unit (1) off and remove it.
7. If necessary, perform a general visual inspection (see 5.6.1) or test (see 5.6.7).

### Installation

1. Bring electronic ignition unit (1, Fig. 804) into installation position and secure with combination screws (4).
2. Reconnect the electronic ignition unit plug to the control device.
3. Fit the disc (3) onto the nozzle holder of the fuel pump (9, Fig. 805) and align it so, the ignition electrode (2, Fig. 804) may be inserted into the electronic ignition unit.
4. Insert ignition electrode (2, Fig. 804) into the electronic ignition unit.
5. Install burner head (see 8.2).

- 1 Electronic ignition unit
- 2 Ignition electrode
- 3 Disc
- 4 Screws (2)
- 5 Light window
- 6 Flame guard

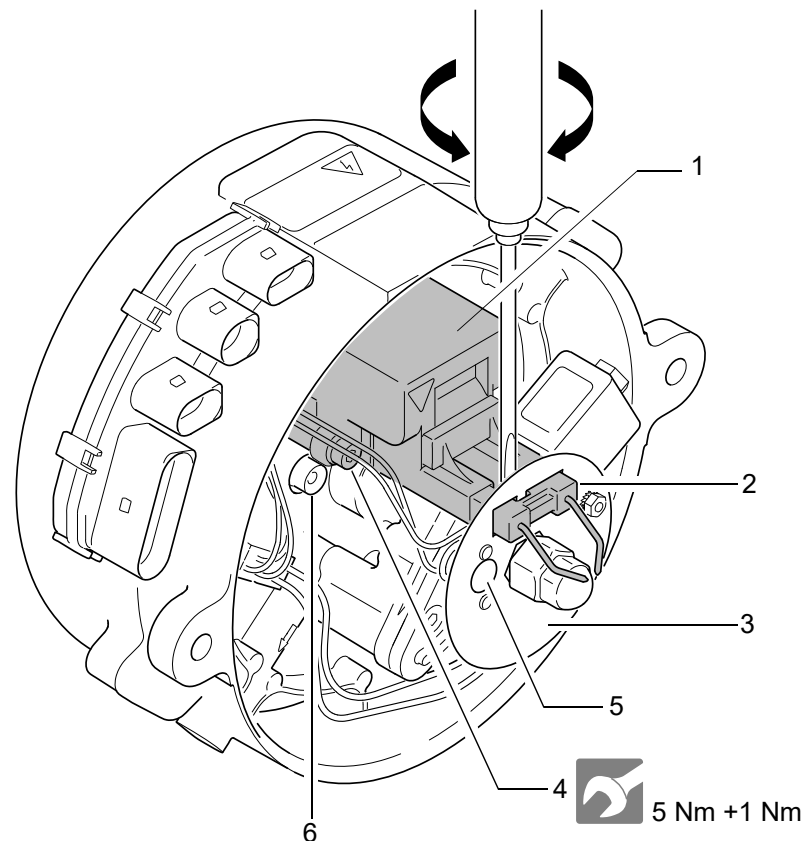

Fig. 804 Electronic ignition unit / ignition electrode removal and installation

## 8.7 Control device removal and installation

### NOTE:

Control device and burner motor constitute a unit and cannot be further disassembled!

### Removal

1. Remove the fuel pump incl. solenoid valve (see 8.8).
2. If necessary remove the coupling (17, Fig. 805) from the shaft of the burner motor.
3. Remove the fan wheel (see 8.5).
4. Remove the 4 screws (13), securing the control device to the burner housing.
5. Remove the 3 screws (16), securing the burner motor to the burner housing.
6. Remove the control device (14) from the burner housing (15).

### Installation

1. Position the control device (14, Fig. 805) onto the burner housing.
2. Screw in the 3 screws (16), securing the burner motor to the burner housing and tighten them.
3. Install the 4 screws (13), securing the control device to the burner housing and tighten them.

4. Install the fan wheel (see 8.5).
5. Put the coupling (17, Fig. 805) onto the shaft of the burner motor.
6. Install the fuel pump incl. solenoid valve (see 8.8).

## 8.8 Fuel pump removal and installation

### NOTE:

Make sure that any fuel leaking is immediately bound and professionally disposed of.

### Removal

1. Remove the electronic ignition unit (see 8.6).
2. Remove disc (3, Fig. 804).
3. If installed, remove the nozzle block preheater (see 8.10).
4. Disconnect the solenoid valve plug from the control device.
5. Remove and discard the 3 screws (12, Fig. 805), securing the fuel pump to the burner housing.
6. Remove the fuel pump (9) incl. solenoid valve (6).
7. Remove and discard the O-rings (10) and the screen insert (11).
8. If necessary remove the solenoid valve (6) from the fuel pump (9) (see 8.9).

- 1 Electronic ignition unit
- 2 Combination screw (2)
- 3 Ignition electrode
- 4 Fuel nozzle
- 5 Disc
- 6 Solenoid valve
- 7 Nozzle block preheater (optional)
- 8 Retaining clamp
- 9 Fuel pump
- 10 O-rings (2)
- 11 Screen insert
- 12 Screws (3)
- 13 Screws (4)
- 14 Control device
- 15 Burner housing
- 16 Screws (3)
- 17 Coupling

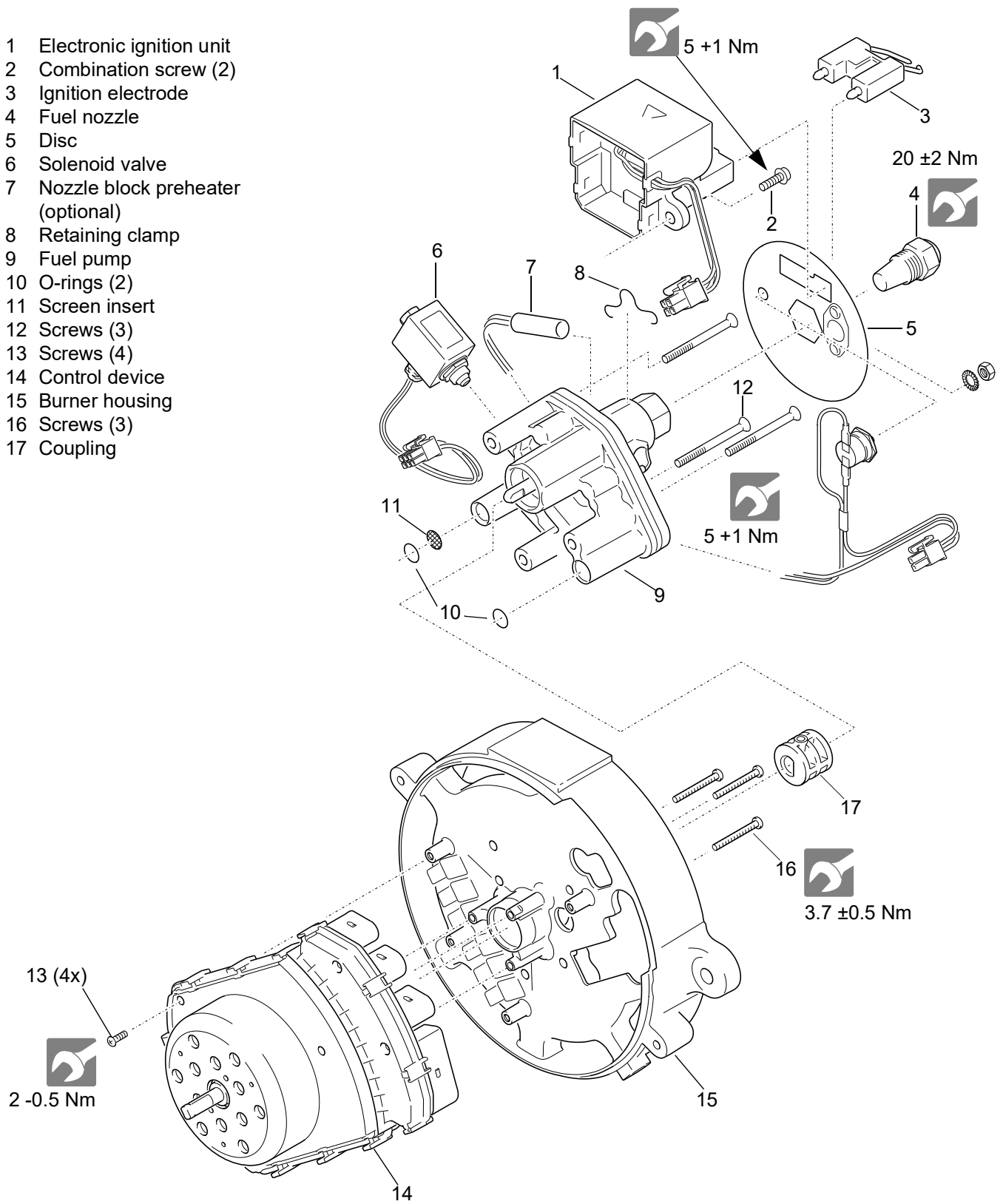

Fig. 805 Components removal and installation

**Installation**

1. If necessary, install solenoid valve (6, Fig. 805) onto the fuel pump (9) (siehe 8.9).
2. Install new O-rings (10) and a new screen insert (11) into the fuel pump (9).

**ATTENTION:**

**In order to avoid damage to the O-rings, to not twist fuel pump (9) during assembly.**

**New screws with coated threads must be used for installing the fuel pump.**

3. Align the fuel pump (9) with the burner housing (15) and bring it into installation position. Before doing this, align if necessary the coupling (17) by rotating it on the burner motor shaft.
4. Mount the fuel pump (9) using 3 new screws (12, with coated threads) and tighten them.
5. Reconnect the solenoid valve (6) plug to the control device (14).
6. If required, install the nozzle block preheater (see 8.10).
7. Install disc (3, Fig. 804).
8. Install electronic ignition unit (see 8.6).

## 8.9 Solenoid valve removal and installation

**NOTE:**

The solenoid valve must be completely replaced and may not be further dismantled! In case of replacement or

assembly and disassembly a new gasket ring must be used.

It is not absolutely necessary to remove the fuel pump for removal of the solenoid valve.

Make sure that any fuel leaking is immediately bound and professionally disposed of.

**Removal**

1. Remove burner head (see 8.2).
2. Lift off ignition electrode (3, Fig. 805) from the electronic ignition unit by twisting a screwdriver sideways (see Fig. 804) and remove it.
3. Remove disc (5, Fig. 805).
4. Disconnect the solenoid valve plug (6) from the control device (14).
5. Using suitable tools loosen the hexagon, wrench size 16 (6, Fig. 806) of the solenoid valve (6, Fig. 805) from the fuel pump (9) and unscrew solenoid valve (6).

**Installation**

1. The gasket ring (10, Fig. 806) towards the fuel pump must be replaced. Observe the proper installation position of plunger, spring and tappet (see Fig. 806). Attach the solenoid valve (6, Fig. 805) to the fuel pump (9).

If the SW12 lock nut (1, Fig. 806) has been inadvertently loosened, tighten the nut to a defined degree ( $2 \pm 0.2$  Nm) and then secure it using thread lock.

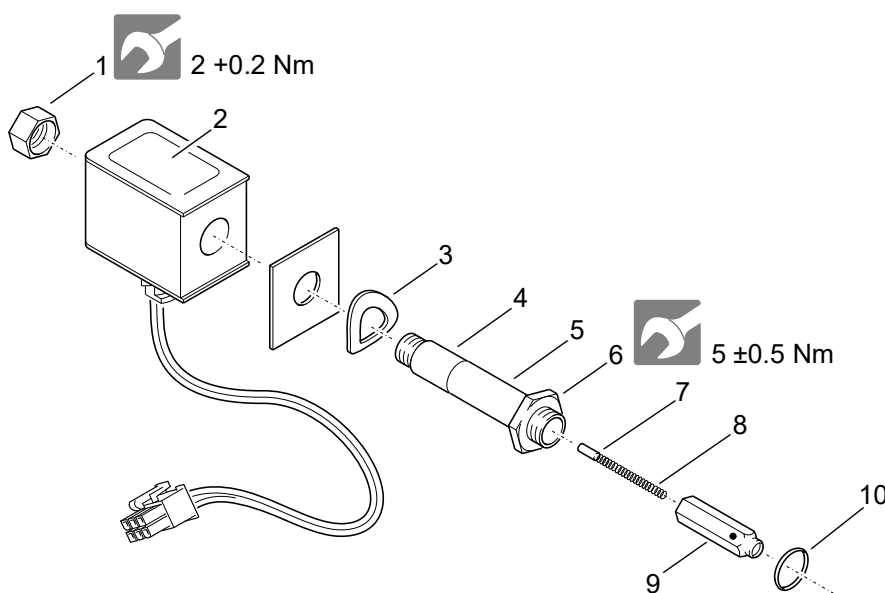

- 1 Nut, wrench size 12
- 2 Magnetic coil (coil with cable, plug and plate)
- 3 Spring washer
- 4 Core
- 5 Tube
- 6 Hexagon, wrench size 16
- 7 Tappet
- 8 Spring
- 9 Plunger
- 10 Gasket ring

Fig. 806 Solenoid valve removal and installation

2. Using a suitable tool, tighten hexagon, wrench size 16 (6, Fig. 806) of the solenoid valve.
3. Connect the solenoid valve plug (6, Fig. 805) to the control device (14).
4. Fit the disc (5) onto the nozzle holder of the fuel pump (9) and align it so, the ignition electrode (3) may inserted into the electronic ignition unit.
5. Insert ignition electrode (3) into the electronic ignition unit.
6. Install burner head (see 8.2).

**ACHTUNG:**

If the nut, wrench size 12 (1, Fig. 806) was loosened, it must be tightened with a tightening torque, see Fig. 806, and then secured using thread lock.

### 8.10 Nozzle block preheater removal and installation

**Removal**

1. Remove burner head (see 8.2).
2. Disconnect nozzle block preheater plug from control device.
3. Lift off ignition electrode (6, Fig. 807) from the electro-

nic ignition unit by twisting a screwdriver sideways (see Fig. 804) and remove it.

4. Remove the nut (5, Fig. 807) and the serrated washer (4) which attach the thermostat (3) to the disc (7) and remove the thermostat.
5. Remove disc (7).
6. Remove retaining clamp (2) of the heating element (1) and pull the heating element out the nozzle block of the fuel pump.

**Installation**

1. Insert heating element (1, Fig. 807) into the nozzle block of the fuel pump and secure it with the retaining clamp (2).
2. Bring the thermostat (3) into installation position.
3. Fit the disc (7) onto the nozzle holder of the fuel pump and align it so, the ignition electrode (6) may inserted into the electronic ignition unit.
4. Insert ignition electrode (6) into the electronic ignition unit.
5. Attach thermostat (3) to the disc (7) using the serrated washer (4) and the nut (5).
6. Reconnect the nozzle block preheater plug to the control device.
7. Install burner head (see 8.2).

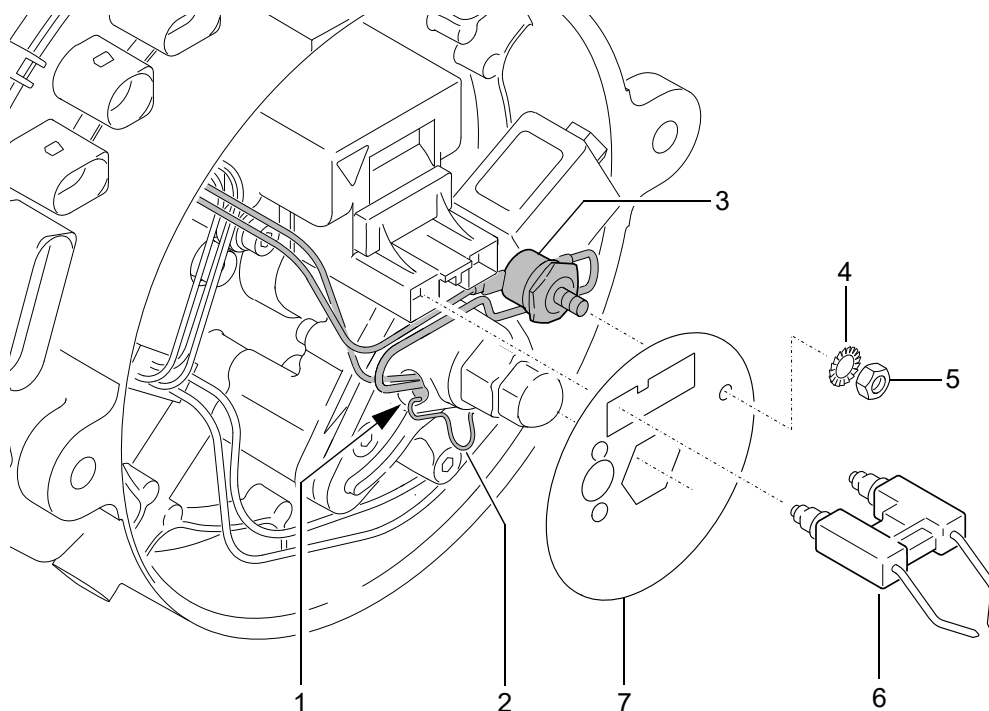

- |   |                    |
|---|--------------------|
| 1 | Heating element    |
| 2 | Retaining clamp    |
| 3 | Thermostat         |
| 4 | Serrated washer    |
| 5 | Nut                |
| 6 | Ignition electrode |
| 7 | Disc               |

Fig. 807 Nozzle block preheater removal and installation

### 8.11 Fuel nozzle removal and installation

#### Removal

1. Remove burner head (see 8.2).
2. Lift off ignition electrode (2, Fig. 804) from the electronic ignition unit by twisting a screwdriver sideways and remove it.
3. Remove disc (5, Fig. 805).

**NOTE:**

Do not touch or attempt to clean the nozzle orifice.

4. Unscrew fuel nozzle (4). It is necessary to counteract with a tool at the hexagon of the nozzle block of the fuel pump (9).

#### Installation

1. Screw in the fuel nozzle (4, Fig. 805) and tighten. It is necessary to counteract with a tool at the hexagon of the nozzle block of the fuel pump (9).
2. Fit the disc (5) onto the nozzle holder of the fuel pump (9) and align it so, the ignition electrode (3) may inserted into the electronic ignition unit.
3. Insert ignition electrode (3) into the electronic ignition unit.
4. Install burner head (see 8.2).

### 8.12 Combustion chamber removal and installation

#### Removal

1. Remove burner head (see 8.2).
2. Pull the combustion chamber (1, Fig. 808) out of the heat exchanger (2).

- 1 Combustion chamber
- 2 Heat exchanger
- 3 Exhaust outlet
- 4 Stand
- 5 Coolant inlet
- 6 Coolant outlet
- 7 Coolant hose (2x)
- 8 Hose clamp (2x)

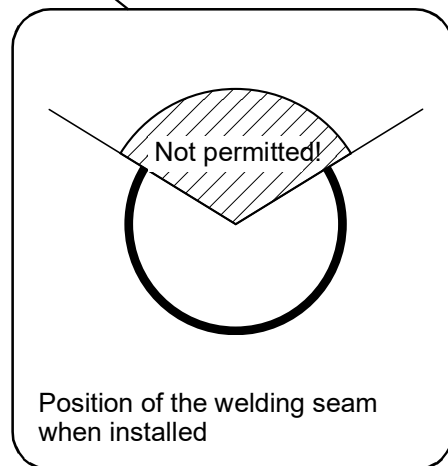
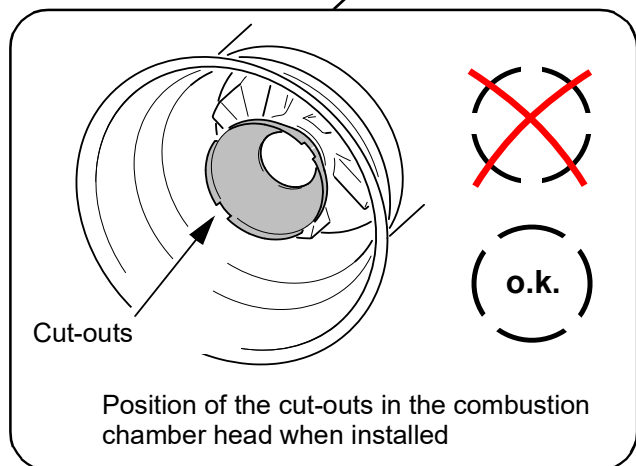
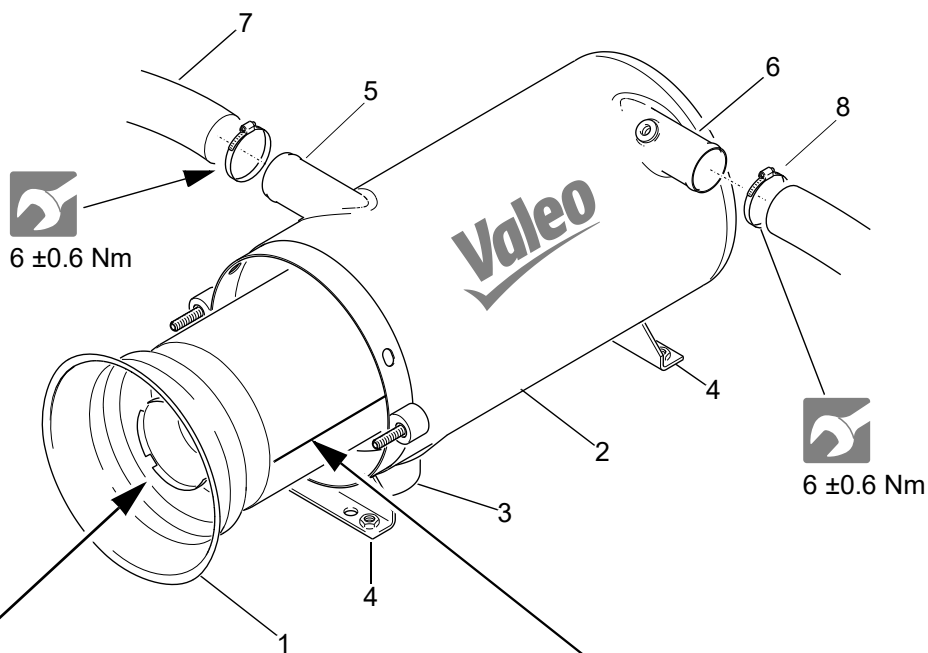

Fig. 808 Combustion chamber removal and installation

## Installation

### ATTENTION:

**When replacing the combustion chamber, ensure that the new combustion chamber corresponds to the heating capacity class of your heating appliance.**

- Slide combustion chamber (1, [Fig. 808](#)) fully into the heat exchanger (2) against stop. Pay attention to
  - the welding seam position, and
  - the position of cut-outs in the combustion chamber head

### NOTE:

- The combustion chamber should be inserted into the heat exchanger in such a way that its welding seam is positioned between 2 and 10 o'clock (not upwards!) ([Fig. 808](#)).  
A position change during maintenance is permissible and affects the expected service life of the combustion chamber positively.
- Position the cut-outs in the combustion chamber head as shown in [Fig. 808](#).  
Dripping from nozzle fuel is so collected in a reservoir between disc and combustion chamber head and will be burned at the next burner operation instead to soil the heater.

- Install burner head (see [8.2](#)).

## 8.13 Heat exchanger removal and installation

### Removal

- Disconnect the heater from the vehicle electrical system (**Observe 5.2 !**).
- Disconnect the temperature sensor plug (3, [Fig. 801](#)).
- Remove combination screws (2) and remove burner head (1) from heat exchanger.
- If necessary, loosen the exhaust line clamp on the exhaust outlet (3, [Fig. 808](#)).
- If available, close water taps.



**Risk of scalds if coolant temperature is increased.**

- Loosen hose clamps on the coolant hoses, pull coolant hoses from the coolant inlet (5) and the coolant outlet (6) and seal with blank plugs.

- Remove screws and washers of the heat exchanger stand (4).
- Pull combustion chamber (1) out of the heat exchanger (2).
- If necessary remove temperature sensor (see [8.3](#)).
- Remove heat exchanger from vehicle.

### Installation

- Position the combustion chamber (1) correctly into the heat exchanger (2) (see [Fig. 808](#)).
- If necessary install the temperature sensor (see [8.3](#)).
- Bring heat exchanger (2, [Fig. 808](#)) into installation position and mount stand (4) using screws, nuts and washers to the vehicle according to the mounting points used.
- If necessary, secure the exhaust line using a clamp to the exhaust outlet (3).
- Fit coolant hoses (7) onto the coolant inlet (5) and the coolant outlet (6) and secure with hose clamps.
- If available, open water taps.
- Bring burner head (1, [Fig. 801](#)) in assembly position and ensure center alignment and correct fit.
- Place nuts (2) and alternately tighten them slightly.
- Tighten nuts (2). For tightening torque, refer to [Fig. 801](#).
- Connect the heater with the vehicle electrical system.
- Bleed coolant circuit (see [8.15.2](#)).

### ATTENTION:

**The two combination nuts M8, connecting the burner head and the heat exchanger, must be tightened to torque, see [Fig. 801](#), each and additional are to be secured using thread lock.**

## 8.14 Heater removal and installation

### NOTE:

The fuel supply system must be subsequently bled (see [8.15.1](#)).

The coolant circuit must be subsequently bled (see [8.15.2](#)).

### Removal

- Remove burner head (see [8.2](#)).
- Remove heat exchanger (see [8.13](#)).

### Installation

- Install heat exchanger (see [8.13](#)).
- Install burner head (see [8.2](#)).
- Bleed coolant circuit (see [8.15.2](#)).



## 8.15 Start-up after burner head or heater installation

The fuel system must be bled after burner installation. The coolant circuit and the fuel system must be bled after heater installation.

The vehicle manufacturer specifications must be observed.

Coolant and fuel connections must be checked for leak-tightness and tight fit during the test run.

If a malfunction occurs during heater operation, troubleshooting must be performed (see chapter 5).

While the vehicle engine is switched off, switch on the heater with circulation pump and ensure that the heat is transferred into the vehicle.

After the engine motor cooled down, the heater must automatically start and stop as soon as the upper switching threshold is reached.

If the heater does not start automatically, it must be verified, whether the heater overheating protection is triggered and the heater is in fault-lockout state.

Release the heater (see 4.6) and repeat the bleeding process.

### 8.15.1 Bleeding the fuel system

The whole fuel supply system including the fuel filter must completely be filled with fuel before initial start-up.

#### ATTENTION:

**Never use the fuel pump to fill / bleed the fuel system!**

#### ATTENTION:

**In the event no fuel comes to the fuel pump during initial start-up (dry run), there is a risk that the fuel pump will be damaged!**

### 8.15.2 Bleeding of the coolant circuit

#### NOTE:

The coolant circuit must be principally bled according to the manufacturer specification.



**Risk of scalds if coolant temperature is increased.**

The Aquavent 5000 (U4814) and Aquavent 6000S (U4855) circulating pumps may only be switched on for bleeding, after dry operation can be excluded.

The Aquavent 5000S (U4854) and Aquavent 6000SC (U4856) circulating pumps may even in dry operation be switched on for bleeding.

Adjust the vehicle heating system to "warm" and refill coolant.

As soon as it is confirmed that the vehicle engine is filled with coolant, run vehicle engine with increased idle speed. Once the cooler thermostat opens, switch the vehicle engine off and check the coolant level. Refill coolant as needed.

## 9 Modifications and retrofits

For further optimization the heaters are continuously improved. Units in the field can usually be upgraded or retrofitted. For this purpose respective modification kits will be available. Information can be found on the Valeo homepage under Service.

### 9.1 Dust protection for the flame guard

The flame guard can be retrofitted with a dust protection. This increases the reliability of its function and reduces maintenance. The dust protection consists of 3 parts (see Fig. 901/ Fig. 902): dust protection tube (1), spring (2) and disc (3).

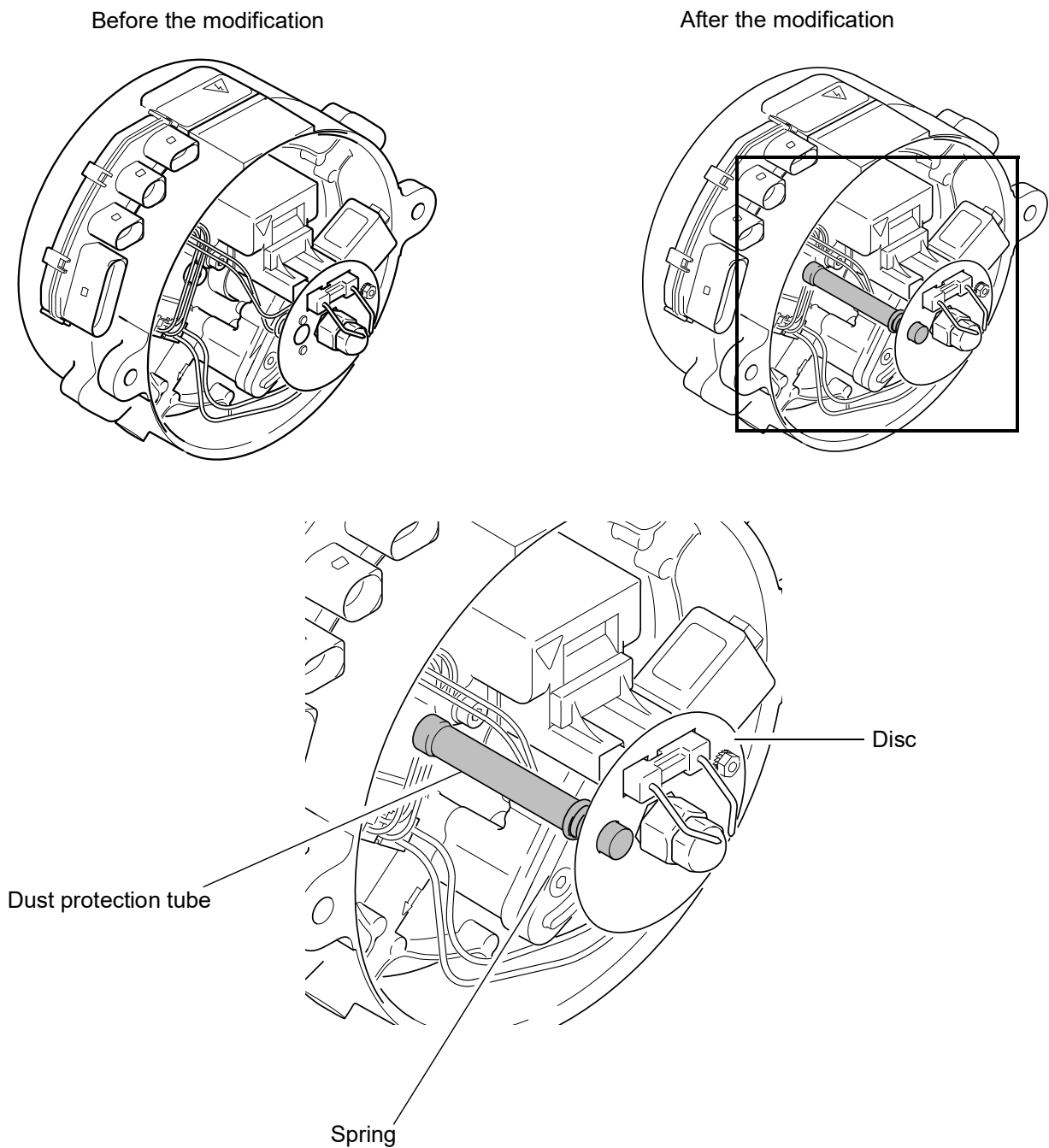

Fig. 901 Flame guard dust protection

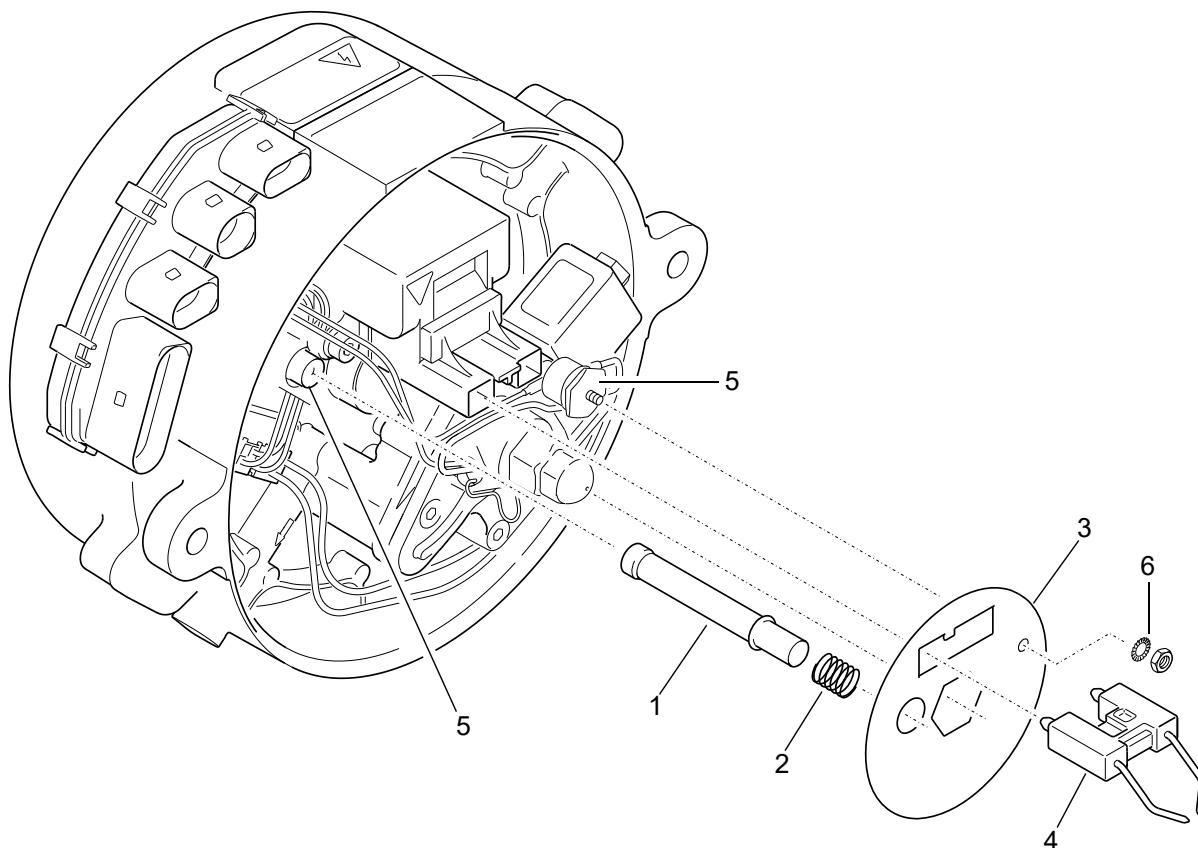

Fig. 902 Flame guard dust protection - Installation

### 9.1.1 Dust protection kit

All required for the retrofit parts

- dust protection tube (1)
- spring (2) and
- disc (3)

are included in the dust protection kit Valeo ID

- 11136327\_  
(for heaters equipped without nozzle block preheating)
- 11136328\_  
(for heaters with nozzle block preheating).

### 9.1.2 Installation

1. Remove burner head (see 8.2).
2. Remove ignition electrodes (4, Fig. 902), refer to 8.6.
3. If installed, remove thermostat (5).
4. Remove disc (3) and discard it.
5. Pre-assemble new disc (3), tube (1) and spring (2).
6. Place new disc (3), tube (1) and spring (1) into position:  
Place disc (3) via atomizer nozzle onto the nozzle block. The lower end of the tube (1) is thereby pushed onto the lens of the flame guard (5). Then turn the disc (3) so that the ignition electrodes (4) can be replaced. Make sure that the components are correctly seated.
7. If required, reinstall the thermostat (5). Pay attention to the correct positioning of the serrated washer (6).
8. Reinstall ignition electrodes (4), refer to 8.6.
9. Reinstall burner head (see 8.2).

## 10 Packing/storage/shipping

### 10.1 General

The heater or its components, which are sent to Valeo for inspection or repair, must be cleaned and packaged to ensure that handling, transport and storage will not damage them.

**ATTENTION:**

**If a complete heater is sent back, it must be completely drained. While packaging and/or shipping it must be ensured that no fuel or coolant can leak.**

Coolant inlet and outlet fittings as well as the fuel lines must be plugged and sealed using blank plugs.

The temperatures described in section 2 may not be exceeded during storage.



## Periodic heater maintenance

The heater should be inspected in periodic time intervals, latest at the beginning of the heating period (time of increased heater usage due to present weather conditions). In principle the regulations of the vehicle manufacturers as well as the relevant regulations of the German Federal Railway Authority (EBA) and its technical service must be

adhered. If there no such regulations, Valeo prescribes the here shown maintenance intervals for common applications. For the execution of the work, the corresponding workshop manual is to be used. If heaters should be used in other vehicles and/or applications, the maintenance intervals may be shortened or extended. In such cases please contact your dedicated Valeo partner for further information.

Address of the operator	Date of maintenance		
	Vehicle data		
<b>Heater data</b>			
Type of heater: Ident. no.: Serial no.:	Operating/ control device data acc. to diagnosis STT (Spheros Thermo Test)	Date of commission	
Fuel                      Diesel fuel <input type="checkbox"/> Biodiesel <input type="checkbox"/> Heating oil EL <input type="checkbox"/>			
<b>Check / Maintenance</b>	<b>Important notes</b>	<b>Check result</b>	<b>Measured values, accomplished repairs</b>
<b>1. Electrical connections</b>		OK      not OK	
a) Examine electrical plug connections and the wiring harness for visible damages, replace as required.		<input type="checkbox"/> <input type="checkbox"/>	
<b>2. Heat exchanger</b>	Determine overheating cause as needed (e.g. water circulation system), check overheat protection.	OK      not OK	
a) Check for external damage, discoloration caused by overheating and leaks.		<input type="checkbox"/> <input type="checkbox"/>	
b) Clean the heat exchanger inside and outside, remove soot and debris.		<input type="checkbox"/> <input type="checkbox"/>	
<b>3. Fuel system</b>	Ensure connections to fuel flow and return lines are sealed tight! If biodiesel is used a semi annual filter change is prescribed by the manufacturer.  Re-tighten screw connections and hose clamps.	OK      not OK	
a) Inspect fuel lines and connections for leakage.		<input type="checkbox"/> <input type="checkbox"/>	
b) Replace fuel filter insert with gasket. resp. replaceable filter.		<input type="checkbox"/> <input type="checkbox"/>	

Subject to modification. For translations the german version is binding. Latest version of this document is provided for download on [www.valeo-thermalbus.com](http://www.valeo-thermalbus.com).



# Maintenance plan

for heaters of type Thermo, Thermo E, Thermo S and Thermo plus in buses und railway vehicles



<p><b>7. Functional check</b></p> <p>a) If available, open shut-off valve of the fuel return line and water line.</p> <p>b) Check fault memory, clear it as needed using the diagnostic tool (STT).</p> <p>c) Check heater functionality.</p> <p><b>Attention:</b> During the maintenance, check all screw connections for tightness (for corresponding torque values see Workshop Manual).</p>	<p>after at least 10 min heater operation</p>	<input type="checkbox"/> <input type="checkbox"/> <input type="checkbox"/>	<input type="checkbox"/> <input type="checkbox"/> <input type="checkbox"/>	
---	---	--	--	--





