



## HEATING SYSTEMS

# THERMO DC 200 THERMO DC 070-140-200

Bus

## Installation and operating instructions

Rev. 03/2023  
Id.No. 11118910F



Highlighted words like Warning!, Caution!, ATTENTION: and NOTE: in these Installation and operating instructions signify the following precautions:

**Warning!**

This caption is used to indicate possible severe injuries or fatal accidents if instructions or procedures are carried out incorrectly or entirely disregarded.

**Caution!**

This caption is used to indicate possible minor injuries if instructions or procedures are carried out incorrectly or entirely disregarded.

**ATTENTION:**

This caption points to actions which may cause material damage.

**NOTE:**

This caption is used to draw attention to an important feature.

Other symbols used in these Installation and operating instructions:

**Symbol  
tightening  
torque**

Identifies in graphics parts (e.g. nuts, bolts) that are to be mounted with a specific tightening torque. The torque values are shown at the symbol and are binding.

**NOTE:** Subject to modification. In multilingual versions the German language is binding. The latest version of this document is provided for download on [www.valeo-thermalbus.com](http://www.valeo-thermalbus.com).



## Table of Contents

1	Statutory regulations governing installation	1	11.3 Installation of the circulation pump	21
	1.1 Statutory regulations governing installation	1	11.4 Tightening torques	22
	1.2 Model plate	2	12 Technical data	23
2	Safety regulations	3	13 Annex	26
3	Use / Version	4	13.1 Differing installation instructions for Thermo DC 200 11126153_	26
	3.1 Installation example	5	13.2 Differing installation instructions for Thermo DC 200 11139411_	29
4	Operating and maintenance instructions	6	13.3 Differing installation instructions for Thermo DC 070-140-200 11141607_	31
5	Installation	7	13.4 Differing installation instructions for Thermo DC 200 11125620_	33
	5.1 Additional potential equalization (PE)	7		
	5.2 690 VDC supply line	7		
	5.3 Overcurrent protection / insulation monitoring device	9		
	5.4 External power supply hook-up	10		
	5.5 Testing the installation	10		
6	Maintenance	11		
7	Faults, troubleshooting, repairs	12		
8	Control elements	13		
	8.1 Switch or relay	13		
	8.2 Pre-selection timer	14		
	8.3 Operation indicator	15		
9	Circulation pump	16		
10	Switching thresholds	16		
11	Installation of the heater - fitting of important assemblies	17		
	11.1 Installation	17		
	11.2 Connection to the vehicle's cooling system	20		



## 1 Statutory regulations governing installation

### 1.1. Statutory regulations governing installation

For the heater exists a type approval according to the ECE Regulations R10 (EMC) No. 06 6641 and R122 (Heater) No. 00 0377.

Installation is governed above all by the provisions in Annex 7 of the ECE Regulation R122. In addition, the electrical safety requirements of ECE Regulation R100 are to be observed.

**NOTE: The provisions of these Regulations are binding within the territory governed by ECE Regulations and should similarly be observed in countries without specific regulations!**

#### **Extract from ECE Regulation R122, Annex 7:**

4 The heater must have a manufacturer's label showing the manufacturer's name, the model number and type together with its rated output in kilowatts. The operating voltage and the electric power must also be stated.

7.1 A clearly visible tell-tale in the operator's field of view shall inform when the heater is switched on or off.

#### **Extract from ECE Regulation R122, Part I:**

### **5.3 Installation Requirements for Combustion Heaters and Electrical Heaters into Vehicles**

#### **5.3.1 Scope**

5.3.1.1 Subject to paragraph 5.3.1.2., heaters shall be installed according to the requirements of paragraph 5.3.

#### **5.3.2 Positioning of combustion heater**

5.3.2.1 Body sections and any other components in the vicinity of the heater must be protected from excessive heat and the possibility of fuel or oil contamination.

5.3.2.2 The heater shall not constitute a risk of fire, even in the case of overheating. This requirement shall be deemed to be met if the installation ensures an adequate distance to all parts and suitable ventilation, by the use of fire resistant materials or by the use of heat shields.

5.3.2.3 In the case of M2 and M3 vehicles, the heater must not be positioned in the passenger compartment. However, an installation in an effectively sealed envelope which also complies with the conditions in paragraph 5.3.2.2 may be used.

5.3.2.4 The label referred to in Annex 7, paragraph 4 or a duplicate, must be positioned so that it can be easily read when the heater is installed in the vehicle.

5.3.2.5 Every reasonable precaution should be taken in positioning the heater to minimize the risk of injury and damage to personal property.

#### **5.3.6 Heating air inlet**

not applicable

#### **5.3.7 Heating air outlet**

not applicable

 <b>Warning!</b>	<b>Danger to life and health!</b>
---	-----------------------------------

Applicable local regulations, laws and standards for electrical installations, in particular the provisions of ECE Regulation R100 are to be observed by the vehicle manufacturer and should be appropriately implemented.

**ATTENTION:**

Failure to follow the installation instructions and the notes contained therein will lead to all liability being refused by Valeo. The same applies if repairs are carried out incorrectly or with the use of parts other than genuine spare parts. This results to the invalidation of the type approval of the heater.

## 1.2. Model plate

The model plate must be protected from damage and must be clearly legible when the heater is installed (otherwise a duplicate model plate must be used).

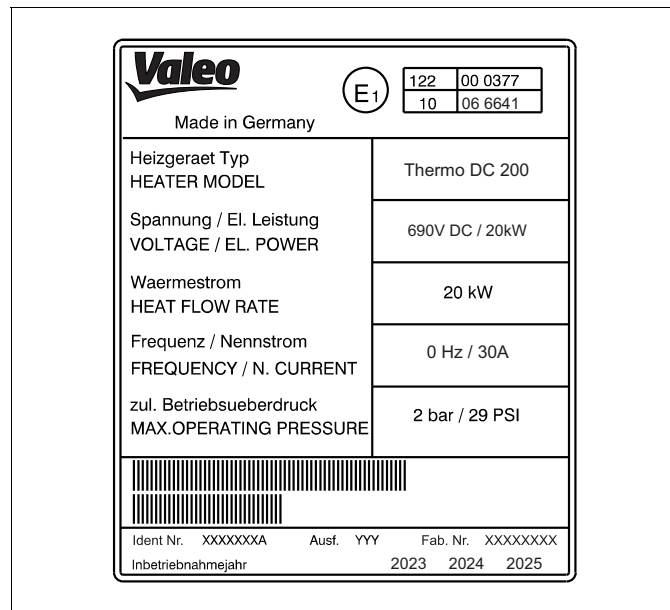

**Figure 1: Model plate (example)**

**NOTE:** The year of the initial operation must be durably marked by removing the year numbers that are not applicable.

## 2 Safety regulations



Installation, maintenance and repairs may only be carried out when the vehicle's engine is not running and the high voltage supply is switched off.

Before starting the work at the heater, it is to make voltageless acc. to DIN VDE 0105-100 and this state must be ensured for the duration of the work.

In particular, the following safety precautions must be observed:

- switch off the power supply to the heater
- ensure it cannot be switched on again
- verify, system is voltage-free, all poles
- ground and short circuit (the de-energized circuit)
- cover neighbouring parts under voltage or secure them against unauthorized entry

Electrical cables and operating elements of the heater must be arranged in the vehicle in such a way that their functioning is faultless under normal operating conditions and cannot be hampered.

Work at electrical equipment may only be started if protective measures against electric shock, short circuits and arcing faults have been carried out.

Electrical work may only be performed by a qualified electrician for HV systems in motor vehicles, craftsman, activity with repetitive character. Training acc. to DGUV 200-005 (previously BGI 8686), at least level 2.

### NOTE:

The provisions of these Regulations are binding within the territory governed by DGUV Regulations and should similarly be observed in countries without specific regulations.

Country specific rules / standards are to be considered additionally.

### 3 Use / Version

The electrical heater can be used in a depot for pre-heating purposes. For this it is connected stably to the depot high voltage (further referred to as HV) DC mains.

Further more the heater also can be used in electric driven buses or hybrid buses where a HV DC power supply is provided, in association with the vehicle's own heating system:

- to heat the passenger cabin, and
- for pre-heating.

The heater may only be installed and operated in vehicles of the class **M2, M3**.

Any use beyond is not permitted.

The heaters operate independently of the vehicle engine and are connected to the vehicle's cooling and electrical systems.

 <b>Warning!</b>	<b>Danger to life and health!</b>
---	-----------------------------------

**The heater is not approved for use in vehicles carrying dangerous goods according to Annex 9 of the UN/ECE Regulation R122.**

#### General Information / Safety

Check the information given on the rating plate of your heater / in the technical data and compare this with your mains voltage!

In addition to the statutory regulations the specific connection conditions of local electricity companies are to be observed.

No alterations to the electrical installation may be undertaken.

The installation and commissioning may only be carried out by a qualified electrician.

Only have any work on the appliance carried out by a specialist company or a qualified person.

The installation instructions are to be considered.

 <b>Caution!</b>	<b>Hot surfaces!</b>
---	----------------------

**Under no circumstances touch the heat exchanger and the water hoses during operation, in particular when they are overheated due to lack of water.**

Ensure an adequate distance to all surrounding parts and a sufficient ventilation during installation.

Alternately use fire resistant materials or heat shields (see Statutory Regulations governing installation, para. 5.3.2.2).



### 3.1. Installation example

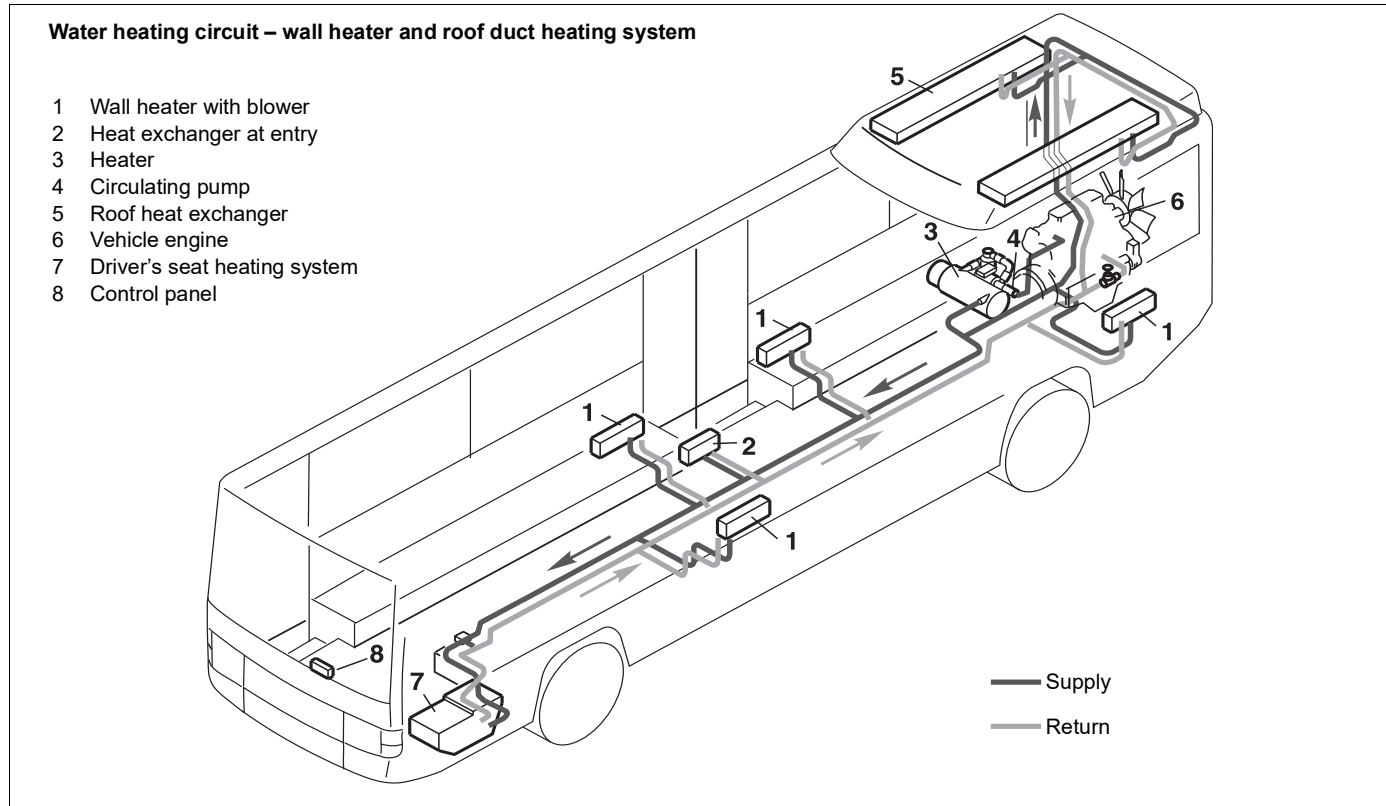

Figure 2: Installation example for the heater

## 4 Operating and maintenance instructions

The Thermo DC heating appliance may not be operated at temperatures of more than +85°C. Amount of antifreeze in the water circuit - see technical data.

**ATTENTION:**

**The heaters may be only used in closed vehicle systems for warming up water.**

**They must not be operated in the depot unattended for a longer period. The pump operation, the water cycle and the water temperature of the vehicle should be monitored. In case of any malfunction make the heater immediately voltageless.**

**Another utilization or any utilization going beyond these ones is to be considered as unintended use. The manufacturer/supplier shall not be liable for damages resulting from unintended use; the user shall bear the risk alone.**

## 5 Installation

### ATTENTION!

Any changes to the heaters or to the installation described below are strictly prohibited and will void both the warranty and, if applicable, the E1 approval.

### 5.1. Additional potential equalization (PE)

A grounding cable, at least 1x6 mm<sup>2</sup> Cu, should be attached to the position on the housing which is marked and provided for it. This is done with a ring cable lug which is fastened with a M10x1 potential equalization screw (for tightening torque, refer to figure 11).

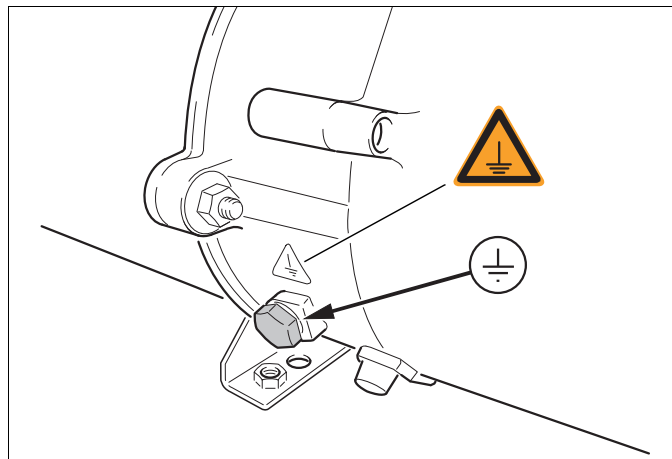

Figure 3: Potential equalization screw

The connecting screws on the heating appliance may only be replaced

with genuine original parts from Valeo, since these are part of the electrical equipment and they ensure proper grounding.

### 5.2. 690 VDC supply line

The hook up must be made with at least a cable corresponding to the heater connection cable (HV). The cable cross-section must be chosen according to the power and installed cable length.

Use a dedicated power circuit for the heating system.

The appliance must have a fixed connection to the DC power supply of the vehicle.

The heating appliance must be connected to the potential equalization.

The connection must be carried out in accordance with the enclosed hook-up diagram (see Figure 4).

### ATTENTION:

When connecting the HV cable, it is essential to ensure the correct current direction. A polarity reversal can lead to the destruction of the heater.

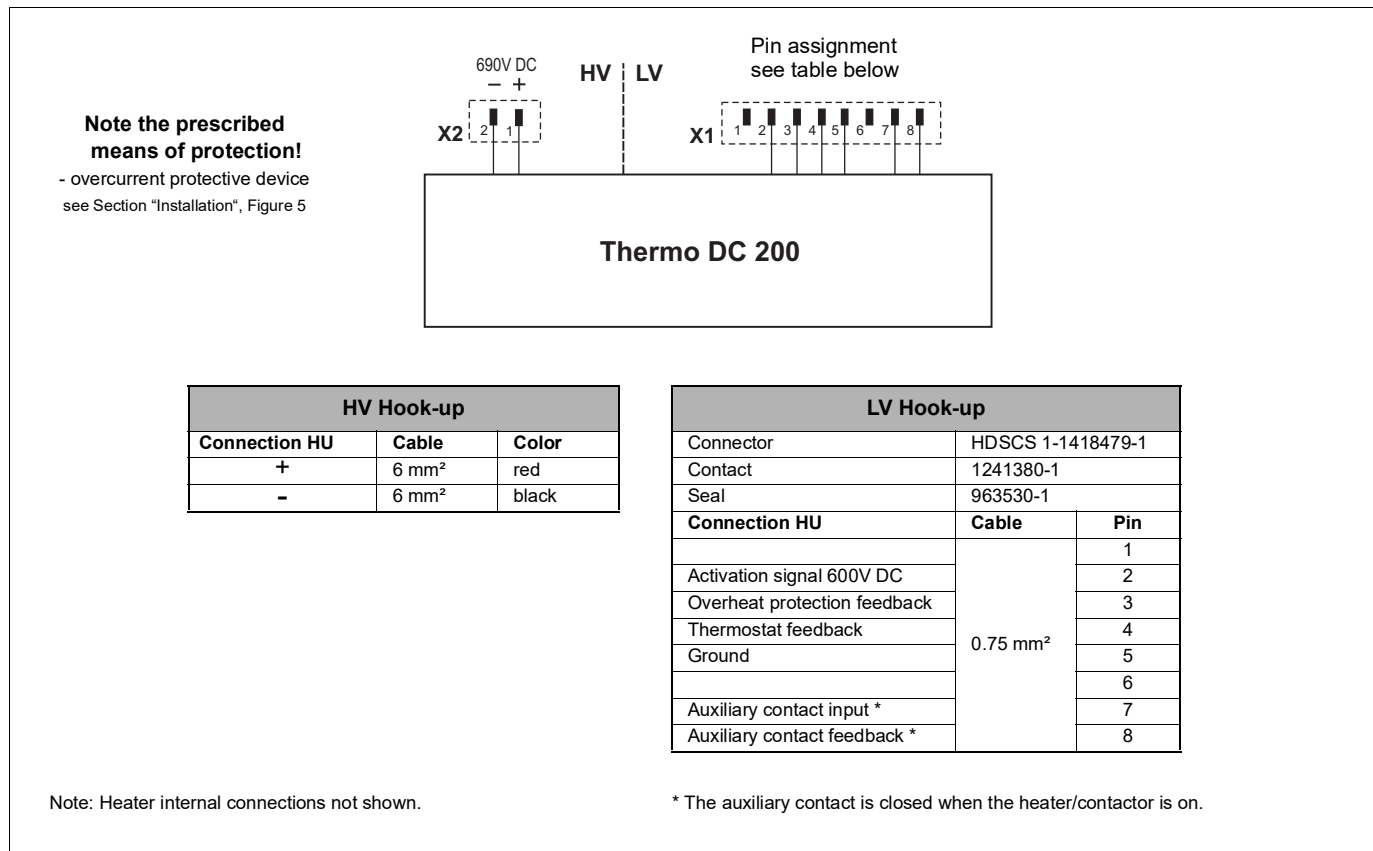

Figure 4: Hook-up diagram

### 5.3. Overcurrent protection / insulation monitoring device

#### ATTENTION:

The power supply circuit is to be protected through an all pole overcurrent protection device acc. to table Technical Tata on page 23.

If the overcurrent device has been triggered, the heater is to be switched off. It is essential that the cause is identified and the error rectified by a qualified electrician in a specialised workshop. Only then the heating appliance can be reconnected to the mains.

The use of overcurrent protection devices with another as specified load ability is not permitted and will result in loss of the operating approval!

 <b>Warning!</b>	<b>High voltage! Danger to life!</b>
---	--------------------------------------

The heater must be protected on the vehicle side with all poles by an insulation monitoring device (tripping resistance 0.5 M $\Omega$ ) against fault currents.

If the Thermo DC is monitored as a subcomponent of the BUS system, the value can be adapted according to the applicable statutory requirements.

The connecting schematic of the insulation monitoring device is shown in figure 5 (for example if monitoring the stand alone device).

The specified for the fasteners torque value must be met.

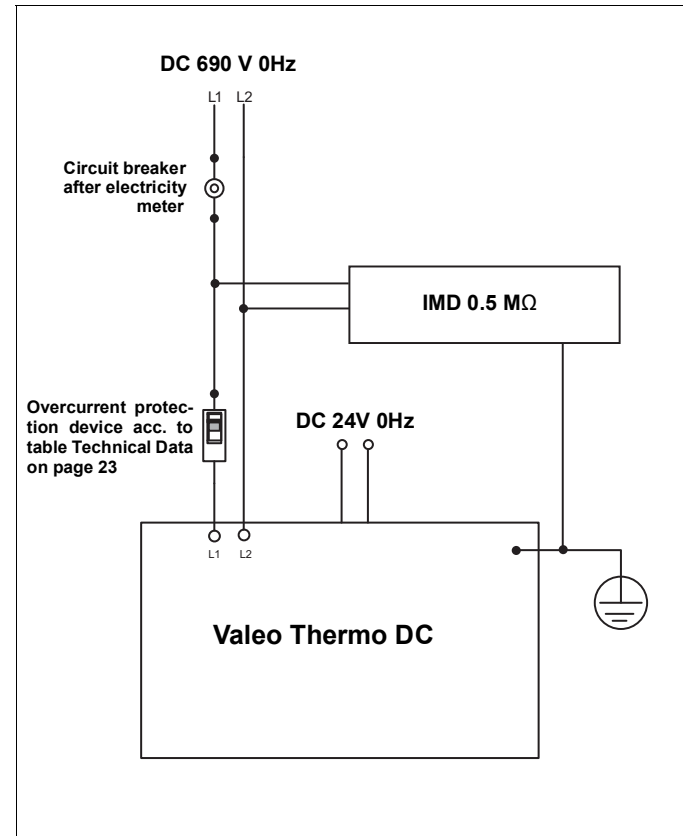

Figure 5: Hook-up schematic

#### 5.4. External power supply hook-up

**ATTENTION:**

**It should be noted that with vehicles, which are to be connected to the earthed external power supply unit via the conductive connection, a device must be present by which the galvanic connection of the electrical earth with the ground can be made.**

Before an external voltage is applied to the vehicle, the connection with the ground must be established by this device and must be able to be maintained until the external voltage is interrupted.

#### 5.5. Testing the installation

After the installation is completed, the heating appliance is to be checked by a qualified electrician for operational safety and function!

A current measurement ensures that all cartridge heaters are functioning. For limits to be checked, refer to table Technical Data on page 23.

**ATTENTION:**

**Under no circumstances may the heaters be operated “dry“ (without water filling), since the internal construction could be damaged!**

## 6 Maintenance



- Maintenance work on the electrical equipment may only be carried out by a qualified electrician.
- The appliance must be disconnected from the power supply prior to any maintenance work and in particular prior to repair work (see 2 Safety regulations).
- The heating appliance, and in particular the electrical control system, must be checked at least once a year according to DIN VDE 0701/0702 (VDE 0701/0702) or according to comparable test specifications. Independently of this the mandatory local regulations must be observed.
- Avoid cleaning with liquid media, as the insulation resistance can be reduced by water that may ingress. See maintenance manual for more information. It is available at [www.valeo-thermalbus.com/eu\\_en/Service/Downloads/Heating-systems/Thermo-AC-DC](http://www.valeo-thermalbus.com/eu_en/Service/Downloads/Heating-systems/Thermo-AC-DC).
- Maintenance must be carried out in accordance with the current maintenance plan, available at [www.valeo-thermalbus.com/eu\\_en/Service/Downloads/Heating-systems/Thermo-AC-DC](http://www.valeo-thermalbus.com/eu_en/Service/Downloads/Heating-systems/Thermo-AC-DC).

### ATTENTION:

- Under no circumstances may the heaters be operated 'dry' to the air, since the internal construction will be damaged!
- Do not operate the cartridge heaters for a short period of time, even for checking purposes, since they can be permanently damaged or destroyed by this. Only carry out checks as instructed.

### NOTE:

The connecting screws on the heating appliance may only be replaced with genuine original parts from Valeo.

A current measurement ensures that all cartridge heaters are functioning. For limits to be checked, refer to table Technical Data on page 23.

## 7 Faults, troubleshooting, repairs

### ATTENTION:

If a safety switch has been triggered, this should only be reset after a qualified electrician has determined the cause of the fault and eliminated the error.



The opening of the appliance, troubleshooting and repairs must only be carried out by a qualified electrician. In all cases the heating appliance must be disconnected from the mains.

Troubleshooting and repair must be done in accordance with the current Workshop Manual, at available at [www.valeo-thermalbus.com/eu\\_en/Service/Downloads/Heating-systems/Thermo-AC-DC](http://www.valeo-thermalbus.com/eu_en/Service/Downloads/Heating-systems/Thermo-AC-DC).

### NOTE:

Damaged or defective components should only be replaced with identical components.

### ATTENTION:

The temperature limiter is triggered at 125°C and interrupts the heating process. To reset you must activate the reset button. Prior to this the heating appliance must be checked for any possible damage or faults and the cause of the fault established and eliminated.



## 8 Control elements

The control line should be kept as short as possible so that the voltage drop is not too great. The minimum cable cross sections indicated in the table must be applied.

Cable length <7,5m	Cable length 7,5 - 15m
0.75 mm <sup>2</sup>	1.5 mm <sup>2</sup> *
2.5 mm <sup>2</sup>	4.0 mm <sup>2</sup> *

\* The cable cross section is to be reduced in front of the heater to 0.75 respective 2.5 mm<sup>2</sup>.

If greater lengths have to be bridged, a relay must be used to split the power circuits and limit the length.  
For the PN of the connector at the heater and of the mating plug, refer to table Technical Data on page 23.

### Kinds of control:

- switch - para. 8.1
- relay - para. 8.1 or via
- pre-selection timer - para. 8.2

### 8.1. Switch or relay

When switching the heater with a switch or relay, these must be designed for a voltage range of 18-30V DC and a current carrying capacity of at least 1.5A.

Use preferably the Valeo switch: 2711011A, switch complete with light.

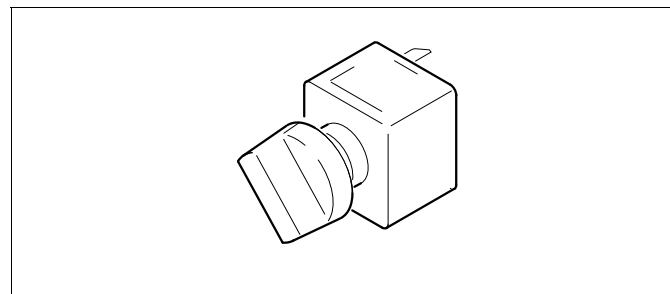

Figure 6: Valeo switch

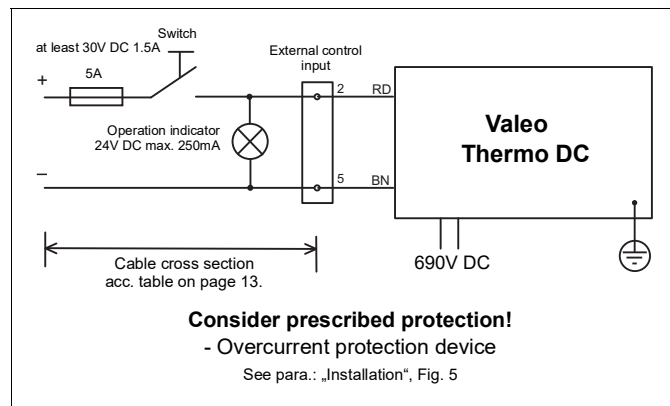

Figure 7: Wiring diagram with switch, 2 pole, without DC-DC converter

## 8.2. Pre-selection timer

If the Valeo pre-selection timer is used as an operational element, a 24V vehicle relay (switching current >1.5A), with a current consumption smaller than 400mA must be used in accordance with the following circuit diagram.

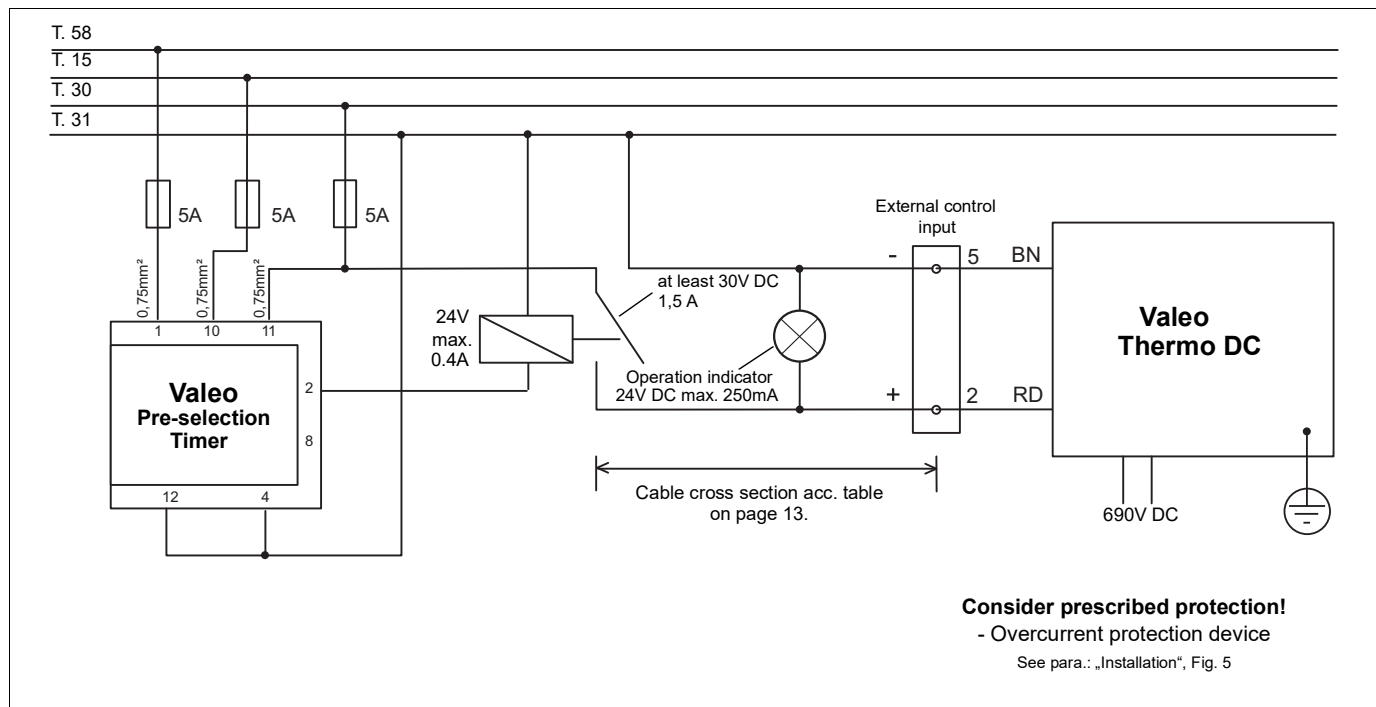

Figure 8: Wiring diagram with pre-selection timer, without DC-DC converter

**ATTENTION:**

Never connect the timer directly to the heating appliance. This will damage the timer. You can use the following relay: ID: 98559A (Fa. Wehrle, 29 201 045).

**NOTE:**

All information on the Valeo pre-selection timer VC Preheater can be found on the Valeo website.

**8.3. Operation indicator**

For monitoring there should be an operation indicator provided at the vehicle, which displays the status of the switching signal/heating system.

**Auxiliary contact**

With pin 7 and 8 (see hook up plan Fig. 4) of the control wiring harness the switching status of the heater can be monitored.

- closed contact: Heater is in operation
- open contact: Heater is off or in a controlled break.

If the operation indicator is integrated into the power circuit for external control, it may require a current of max. 250mA. Only suitable lamps for the voltage range of 18 - 30V are to be used (ref. also para. 8.1, Fig. 7 and 8).

## 9 Circulation pump

### ATTENTION:

**For a correct switching on of the heating appliance an adequate circulation of the cooling medium must be ensured before switching on.**

The heating appliance is preferably to be equipped with Valeo circulation pumps.

### NOTE:

For information about these circulating pumps and their installation, see [http://www.valeo-thermal-bus.com/eu\\_en/Products/Pumps](http://www.valeo-thermal-bus.com/eu_en/Products/Pumps)



The water flow rate through the heat exchanger of the Thermo DC must be more than 1,500 litres/hour. The system must be completely bled.

The triggering/activation of the circulation pump is not carried out by the heating appliance. For this reason the coolant demand must be provided for at the vehicle.

## 10 Switching thresholds

Upper switching threshold: 75°C

Lower switching threshold: 68°C

## 11 Installation of the heater - fitting of important assemblies

### 11.1. Installation

#### ATTENTION:

- The legal regulations for the installation are to be observed.
- If the operation of the water heating appliance is to be part of a separately installed heating system, an installation plan should be presented in all cases to Valeo for approval.  
If this approval is not given, the installation is not permitted and all warranties and liability claims become void.
- Mechanical strain must not be applied to the cables of the temperature switches (e.g. by using them to carry the heating appliance).
- Heating appliances and circulation pumps must fundamentally be built in such that any damage through contamination from the track, water spray, exhausts and other damaging influences is excluded.
- The disassembly of the individual components (contactor, cart-ridge heaters) is not permitted and makes all warranty claims void.



The cooling water and the components of the cooling water circuit achieve high temperatures.

- Water-carrying parts are to be routed and fastened in such a manner that no temperature risk to humans, animals or material sensitive to temperature due to radiation / contact occurs.

- Before working on the cooling water circuit, switch off the heater and wait until all parts are cooled down, if necessary wear protective gloves.

#### NOTE:

The heaters are approved for horizontal installation only (see Figure 10).

The dimensions of the heating appliance, the permitted installation locations, and the hole pattern for the fastening can be found in figures 9 and 10.

#### Installation location

Attention should be paid to the particular location conditions of the specific vehicle type.

The heating appliance and the circulation pump are integrated into the cooling system (or into a separate heating circuit). The heating appliance should be installed as low as possible so that bleeding of the heating appliance and the circulation pump is automatically assured. This is particularly important since the circulation pump is not self-priming. If the heating appliance and the circulation pump can not be accommodated in the engine room of the vehicle, they can be installed in a sealed housing. This housing must be adequately ventilated from the outside, so that a maximum temperature of +85°C inside is not exceeded.

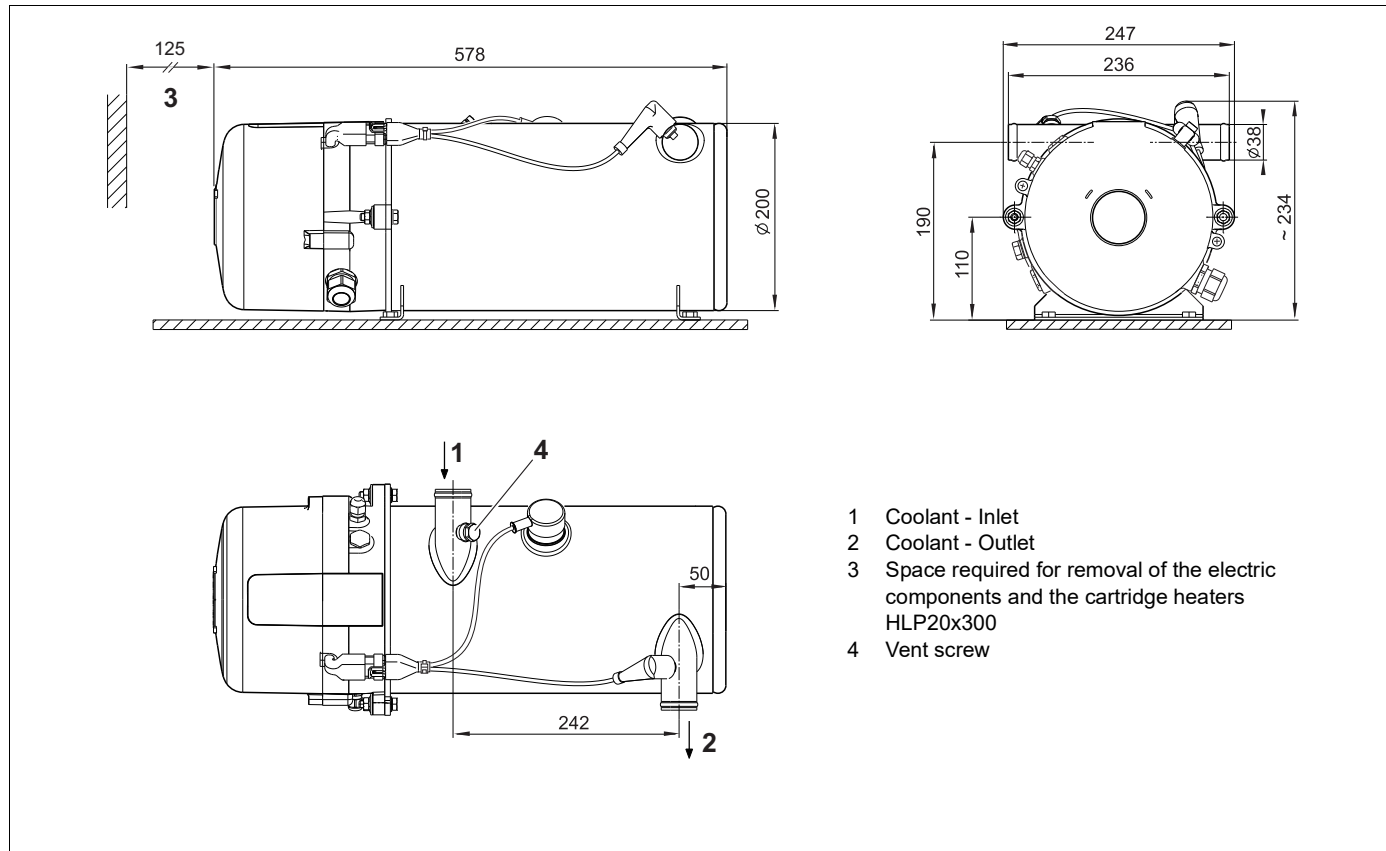

Figure 9: Dimensions of the heating appliance Thermo DC



## 11.2. Connection to the vehicle's cooling system

The heating appliance is connected to the vehicle's cooling system according to figure 9. The volume of coolant fluid present in the circuit must be at least 25 liters. The water in the heating circuit of the heating appliance must contain at least 30 to 60% of a branded antifreeze agent. An up-to-date list of Valeo recommended anti-freeze agents can be found on the Valeo website.

Basically, the by Valeo approved water hoses must be used. If this is not the case, the hoses must at least comply with DIN 73411. The hoses are to be laid without kinks and also rising where possible for the proper bleeding of the heating appliance. The heater must be mounted below the minimum water level of the cooling circuit. Hose connections are to be secured with hose clamps against slipping off.

When installing the electric heater the direction of the flow of the cooling water in the circuit is to be considered (see figure 9).

### ATTENTION:

**The specified tightening torques of the hose clamps used must be adhered.**

In the vehicle cooling system, or in the case of a separate heating circuit, only overpressure valves with an opening pressure of maximum 2 bar should be used.

Attention should be paid to the **careful bleeding of the cooling system** without usage of the circulating pump, before the first commissioning of the heating appliance, or after the coolant fluid has been replaced.

For that the additional venting option via the vent screw item 4, figure 9 is to be used after the system has been filled and the pump has been switched on.

The heat exchanger and the water hoses of the Thermo DC should be pre-filled completely. Loosen the vent screw slightly until no air further

emerges, but only water. Then retighten the screw (tightening torque - see figure 11).

### ATTENTION:

**If air bubbles are present, they could cause destruction of the cartridge heaters!**

The heating appliance and pipes must be installed in such a way that they ensure a static bleeding of the system.

The correct degree of bleeding results in an almost silently operating circulation pump. An inadequate bleeding can lead during heating operation to the switching-off of the heating appliance due to overheating.

Where the U 4855 / Aquavent 6000C circulation pump is used, the circulation pump is automatically switched off ca. 10 seconds after switching on, if the cooling agent is not present or there is blockage of the pump impeller, and it can be started up again after ca. 2 minutes.

Where the U 4856 / Aquavent 6000SC circulation pump is used, the circulation pump is automatically switched off ca. 45 seconds after switching on, if the cooling agent is not present or there is blockage of the pump impeller, and it can be started up again after ca. 2 minutes.

### ATTENTION:

**Before commissioning the heating system, the water hoses, the circulation pump and the heating appliance must be filled completely.**

**Only by Valeo recommended anti-freeze agents may be used.**



### 11.3. Installation of the circulation pump

Consider the information regarding the installation provided in the documentation of your circulation pump. Note the installation position! Refer to Section 9.

**NOTE:**

The pump ports and connection lines from the water intake and water outlet must be flush (no stress).

**ATTENTION:**

**If the pump is not controlled by the heater, its operation is to be ensured by all means during whole heater operation (initial cycle, heating operation and purge cycle). At least turn on the Thermo DC and pump at the same time, but ensure the operation of the pump by an appropriate control circuit at least 2 to 3 min. after switching-off the heater.**

11.4. Tightening torques

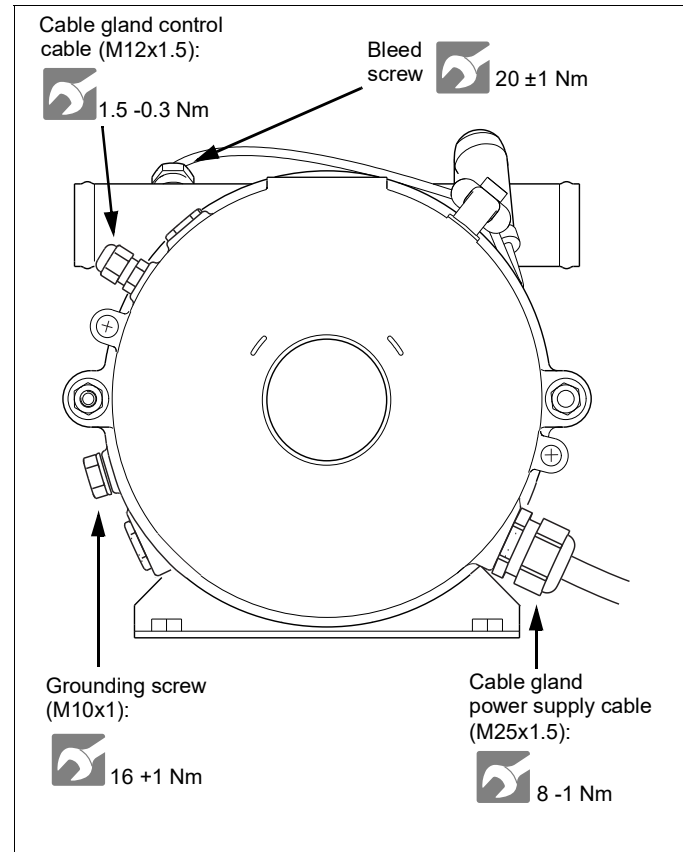

Figure 11: Tightening torques

## 12 Technical data

Unless limit values are given, the technical data below is understood to be subject to the usual tolerances for heating appliances of +/-10% at an ambient temperature of +20°C and at nominal voltage.

**NOTE:**

The allocation of the circulation pumps to the heating appliances must be carried out according to the upstream resistances and the minimum flow rate.

Heater		Thermo DC200	
Ident. no.		11117083_	11122596_, 11139411_, 11125503_, 11122677_
Kind of Design		full electrical heater	
Ambient temperature during operation	°C	-40 ... +85	
Storage temperature	°C	-40 ... +90	
Operating overpressure	bar	max. 2.0	
Capacity of the heat exchanger	l	9.4	
Minimum water flow	l/h	> 1500	
Minimum capacity of the water system	l	25	
Antifreeze ratio in the cooling system	%	30 up to 60	
Maximum operating altitude	m	2000	
Device dimensions (tolerance ± 3 mm)	mm	length: 578 wide: 247 height: approx. 225	
Weight	kg	15	

Continued on next page

Heater (electrical system)		Thermo DC200	
		11117083_	11122596_, 11139411_, 11125503_, 11122677_
Nominal heating flow	kW	20	
Nominal voltage	VDC	690	
Nominal power consumption	kW	20	
Nominal current	A	29.6	
Rated current at 540V DC	A	23.2	
Rated current at 690V DC	A	29.6	
Rated current at 750V DC	A	32.3	
Rated current at 900V DC	A	--	38.6
Type of electrical protection		1000V DC/xxA/10kA fast-blow	1000V DC/xxA/10kA fast-blow
Circuit breaker rating	A	35	50*
Operating voltage range HV	VDC	450 - 750	0 - 900
Cross section HV supply cable	mm <sup>2</sup>	4	6
HV wiring harness at heater side		2ea Ferrules 4mm <sup>2</sup>	2ea ferrules 6mm <sup>2</sup>
Min. cable cross section at vehicle side	mm <sup>2</sup>	4	6
Insulation resistance new device at 1000V	MΩ	>100	

Continued on next page

Heater (electrical system)		Thermo DC200	
Ident. no.	11117083_	11122596_, 11139411_, 11125503_, 11122677_	
Insulation resistance end of life at 1000V	MΩ	>50	
Control signal nominal voltage	VDC	--	24
Operating voltage range LV	VDC	--	16 - 32
Max. control current LV	A	0.42	1.58
LV circuit breaker current rating	A	5	
LV control harness connector	FEP 42064500	AMP HDSC 8 pin 1-1418479-1	
Mating connector	FEP 42121100	AMP HDSC 8 pin 1-1564416-1 or 1-1564512-1	

\* **NOTE:**

The circuit breaker rating is based on the maximum operating voltage of 900V DC. The rating must be adapted to the highest operating current and the temperature derating of the circuit breaker.

## 13 Annex

The installation of the heater must be carried out according to the instructions described in the EBA (Chapter 1-11), except for the deviations described and illustrated on the following pages.

### 13.1. Differing installation instructions for Thermo DC 200 11126153\_

#### Installation

##### Additional potential equalization (PE)

A PE cable, at least 1x10mm<sup>2</sup> Cu, should be attached durable to the position on the housing which is marked and provided for it. This is done with a ring cable lug which is fastened with a M10x1 potential equalization screw incl. washer (Fig. 12, for tightening torque, refer to Fig. 11).

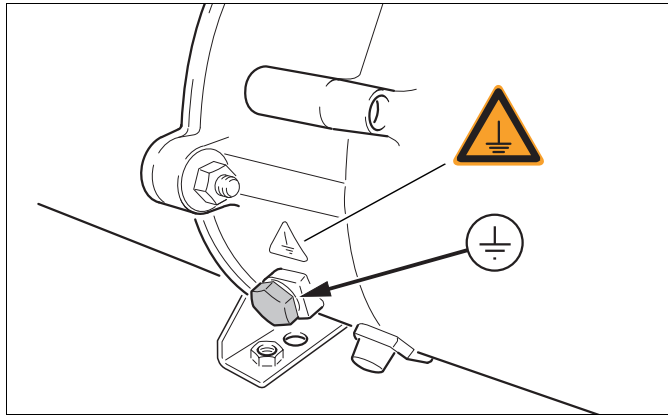

Figure 12: Potential Equalization Screw

The connecting screws on the heating appliance may only be replaced with genuine original parts from Valeo, since these are part of the electrical equipment and they ensure proper grounding.

##### 486V DC supply line

The hook up must be made with at least a cable with 10mm<sup>2</sup> cross section corresponding to the heater connection cable (HV). The cable cross section must be chosen additional according to the power and installed cable length. Use a dedicated power circuit for the heating system.

The device must have a fixed connection to the DC power supply.

The heater must be connected to the potential equalization.

The connection must be carried out in accordance with the enclosed hook-up diagram (see Figure 13).

##### ATTENTION:

**When connecting the HV cable, it is essential to ensure the correct current direction. A polarity reversal can lead to the destruction of the heater.**

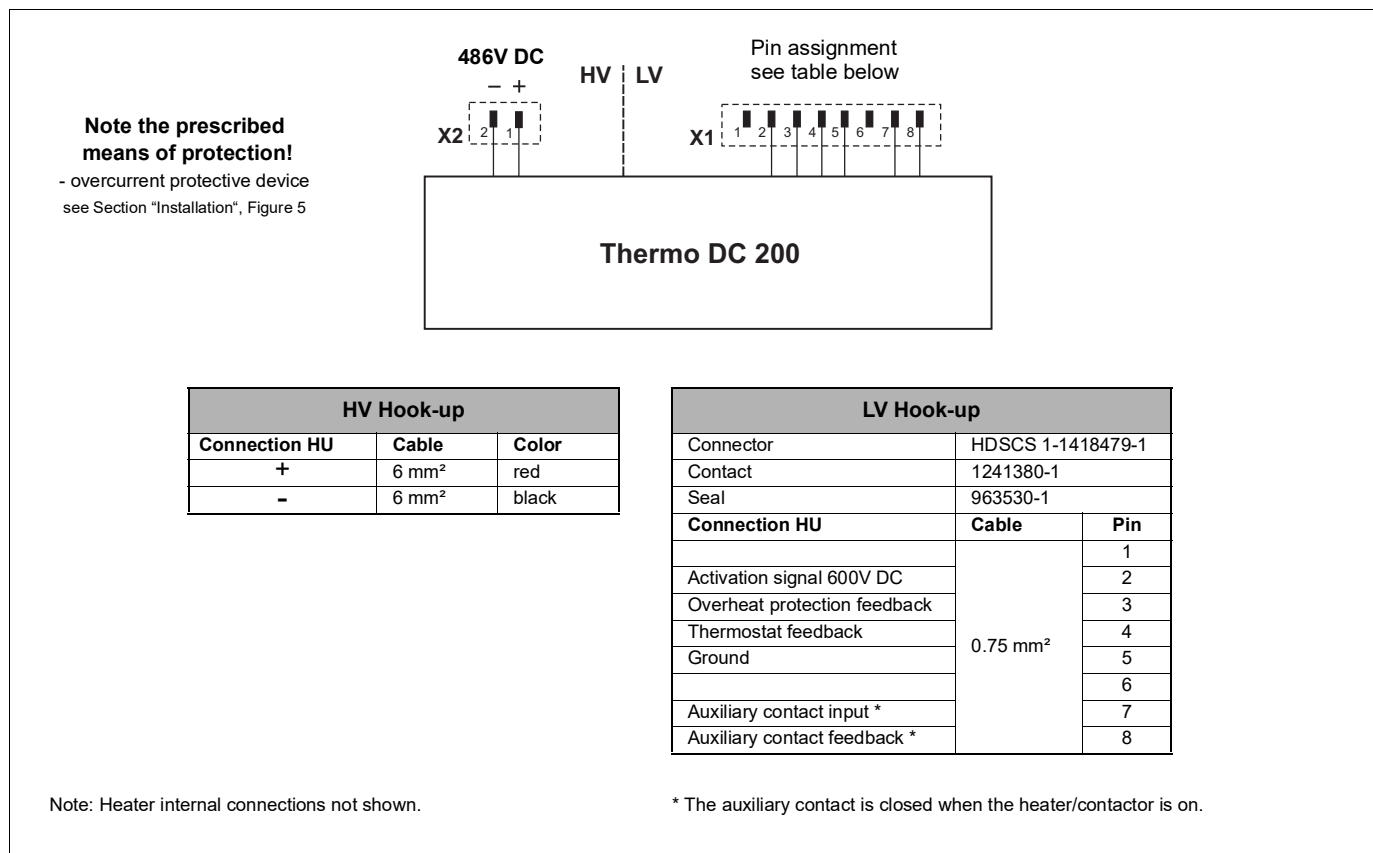

Figure 13: Hook-up diagram Thermo DC 486V DC



Bild 14: Hook-up schematic

## Technical data

Heater (electrical system)		Thermo DC200 (486V)
Ident. no.		11126153_
Nominal heating flow	kW	20
Nominal voltage	VDC	486
Frequency	Hz	--
Nominal current	A	41,7
Rated current at 400V DC	A	34,4
Rated current at 486V DC	A	41,7
Rated current at 540V DC	A	46,4
Rated current at 600V DC	A	51,5
Type of electrical protection		1000V DC/xxA/10kA fast-blow
Circuit breaker rating	A	60*
Operating voltage range HV	VDC	0 - 600
Cross section HV supply cable	mm <sup>2</sup>	10
HV wiring harness at heater side		2ea ferrules 10mm <sup>2</sup>
Min. cable cross section at vehicle side	mm <sup>2</sup>	10
Insulation resistance new device at 1000V	MΩ	>100
Insulation resistance end of life at 1000V	MΩ	>50

Continued on next page

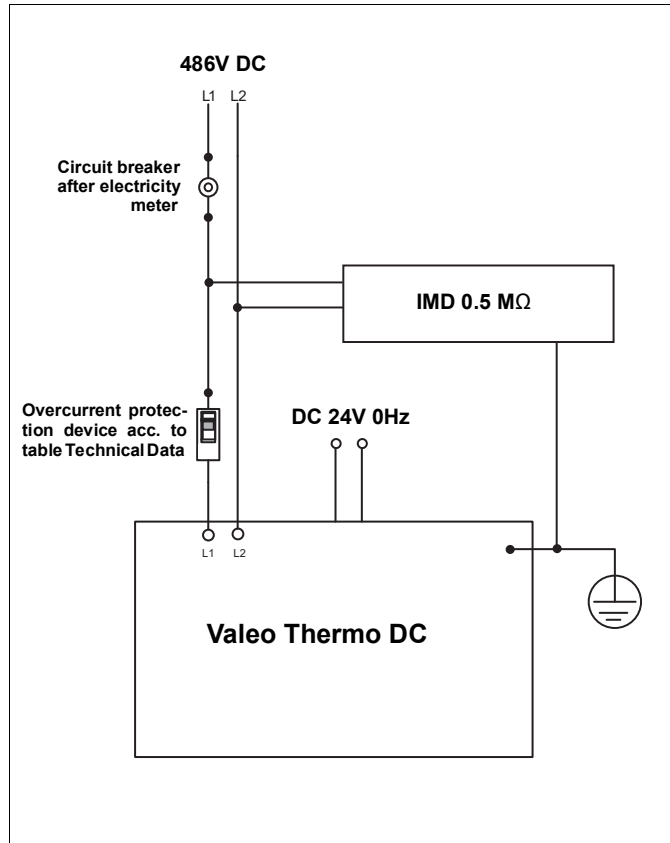

Heater (electrical system)		Thermo DC200 (486V)
Ident. no.		11126153_
Control signal nominal voltage	VDC	24
Operating voltage range LV	VDC	16 - 32
Max. control current LV	A	1,58
LV circuit breaker current rating	A	5
LV control harness connector		AMP HDSC 8 pin 1-1418479-1
Mating connector		AMP HDSC 8 pin 1-1564416-1 o. 1-1564512-1

\* **NOTE:**

The circuit breaker rating is based on the maximum operating voltage of 600V DC. The rating must be adapted to the highest operating current and the temperature derating of the circuit breaker.

### 13.2. Differing installation instructions for Thermo DC 200 11139411\_

The hook-up is to be done according to the hook-up diagram (see Fig. 15).

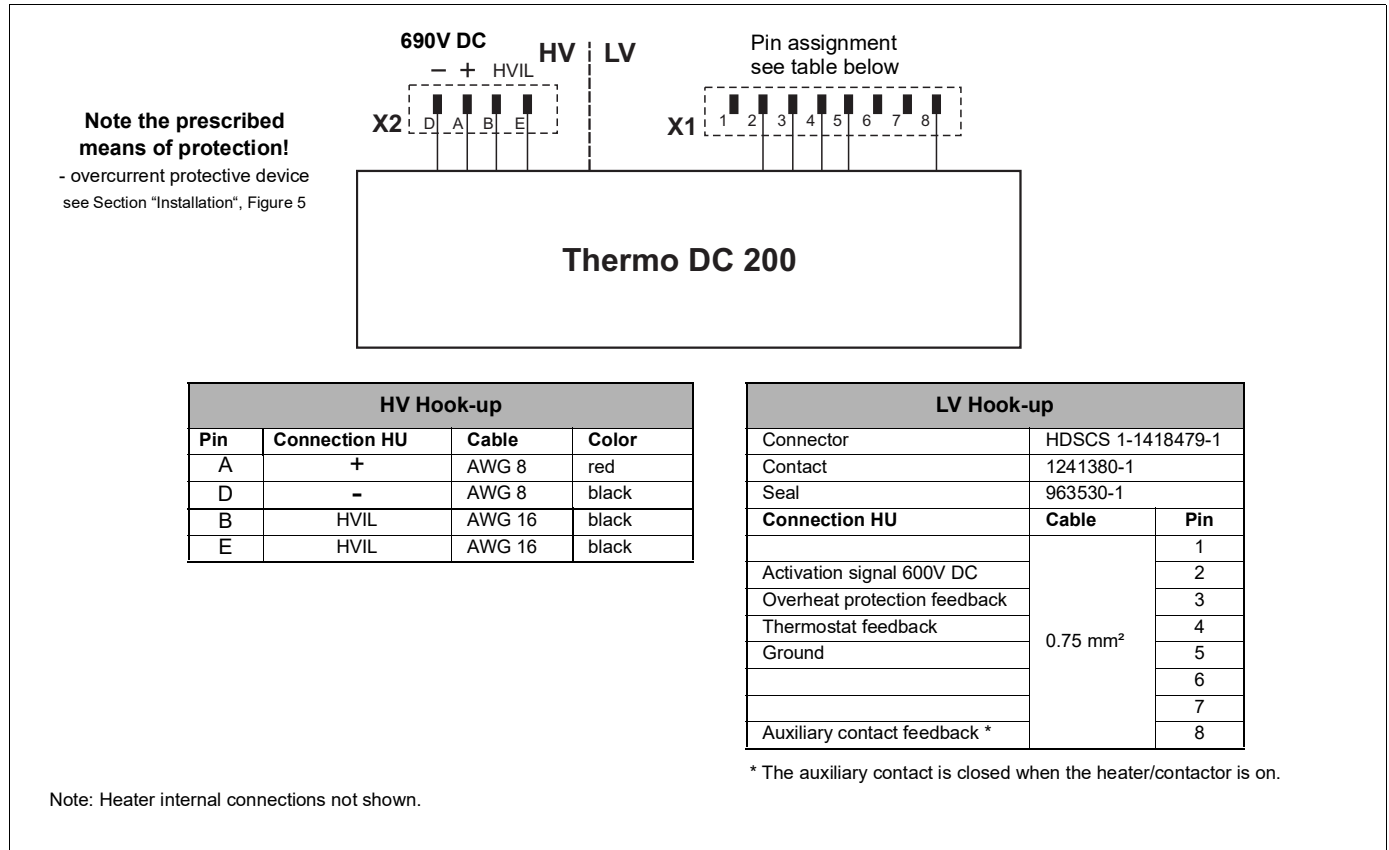

Figure 15: Hook-up diagram Thermo DC 690V DC

### 13.3. Differing installation instructions for Thermo DC 070-140-200 11141607\_

#### 690 VDC supply line

The hook up must be made with at least a cable corresponding to the heater connection cable (HV). The cable cross-section must be chosen according to the power and installed cable length.

Use a dedicated power circuit for the heating system.

The appliance must have a fixed connection to the DC power supply.

The heating appliance must be connected to the potential equalization.

The connection must be carried out in accordance with the enclosed hook-up diagram (see Figure 16).

#### Technical data

Heater (electrical system)		Thermo DC 070-140-200 (690V)
Ident. no.		11141607_
Nominal heating flow	kW	20
Nominal voltage	VDC	690
Frequency	Hz	--
Nominal current	A	9.8/19.5/29.6
Rated current at 540V DC	A	7.8/15.6/23.3
Rated current at 690V DC	A	9.8/19.5/29.6
Rated current at 750V DC	A	10.7/21.5/32.2
Rated current at 900V DC	A	12.9/25.7/38.6

Heater (electrical system)		Thermo DC 070-140-200 (690V)
Ident. no.		11141607_
Type of electrical protection		1000V DC/xxA/10kA fast-blow
Circuit breaker rating	A	50*
Operating voltage range HV	VDC	0 - 900
Cross section HV supply cable	mm <sup>2</sup>	6
HV wiring harness at heater side		2ea ferrules 6 mm <sup>2</sup>
Min. cable cross section at vehicle side		6
Insulation resistance new device at 1000V		MΩ >100
Insulation resistance end of life at 1000V		MΩ >50
Control signal nominal voltage		VDC 24
Operating voltage range LV		VDC 16 - 32
Max. control current LV		A 1.58
LV circuit breaker current rating		A 5
LV control harness connector		AMP HDSC 16 pin 1-1564337-1
Mating connector		AMP HDSC 16 pin 1-1564528-1 o. 1-1564407-1

**\* Note:**

The circuit breaker rating is based on the maximum operating voltage of 900V DC. The rating must be adapted to the highest operating current and the temperature derating of the circuit breaker.

**Note the prescribed means of protection!**

- overcurrent protective device  
see Section "Installation", Figure 5

HV Hook-up		
Connection HU	Cable	Color
+	10 mm <sup>2</sup>	red
-	10 mm <sup>2</sup>	black

LV Hook-up		
Connector	HDSGS 1-1564337-1	
Contact	96427C-1	
Seal	963530-1	
Connection HU	Cable	Pin
--	0.75 mm <sup>2</sup>	1
Activation 690V 1 DC		2
Overheat protection feedback		3
Thermostat feedback		4
HVIL Input		5
HVIL Output		6
Feedback contactor input		7
--		8
Feedback contactor 1 *		9
Activation signal 690V 2 DC		10
Feedback contactor 2 *		11
--		12
--		13
--		14
GND		15
--		16

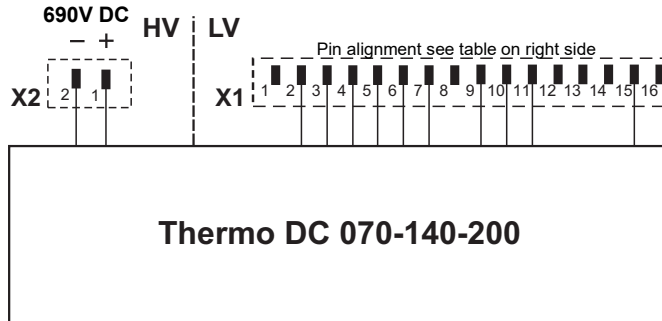

Note: Heater internal connections not shown.

\* The auxiliary contact is closed when the heater/contactor is on.

Figure 16: Hook-up diagram Thermo DC 690V DC

### 13.4. Differing installation instructions for Thermo DC 200 11125620\_

#### 690 VDC supply line

The hook up must be made with at least a cable corresponding to the heater connection cable (HV). The cable cross-section must be chosen according to the power and installed cable length.

Use a dedicated power circuit for the heating system.

The appliance must have a fixed connection to the DC power supply.

The heating appliance must be connected to the potential equalization.

The connection must be carried out in accordance with the enclosed hook-up diagram (see Figure 17).

#### Technical data

Heater (electrical system)		Thermo DC200 (690V)
Ident. no.		11125620_
Nominal heating flow	kW	20
Nominal voltage	VDC	690
Frequency	Hz	--
Nominal current	A	29.6
Rated current at 540V DC	A	23.3
Rated current at 690V DC	A	29.6
Rated current at 750V DC	A	32.2
Rated current at 900V DC	A	38.6

Heater (electrical system)		Thermo DC200 (690V)
Ident. no.		11125620_
Type of electrical protection		1000V DC/xxA/10kA fast-blow
Circuit breaker rating	A	50*
Operating voltage range HV	VDC	0 - 900
Cross section HV supply cable	mm <sup>2</sup>	6
HV wiring harness at heater side		Ring type terminal end 8mm/10mm <sup>2</sup>
Min. cable cross section at vehicle side	mm <sup>2</sup>	6
Insulation resistance new device at 1000V	MΩ	>100
Insulation resistance end of life at 1000V	MΩ	>50
Control signal nominal voltage	VDC	24
Operating voltage range LV	VDC	16 - 32
Max. control current LV	A	1.58
LV circuit breaker current rating	A	5
LV control harness connector		AMP HDSC 8 pin 1-1418479-1
Mating connector		AMP HDSC 8 pin 1-1564416-1 o. 1-1564512-1

**\* Note:**

The circuit breaker rating is based on the maximum operating voltage of 900V DC. The rating must be adapted to the highest operating current and the temperature derating of the circuit breaker.

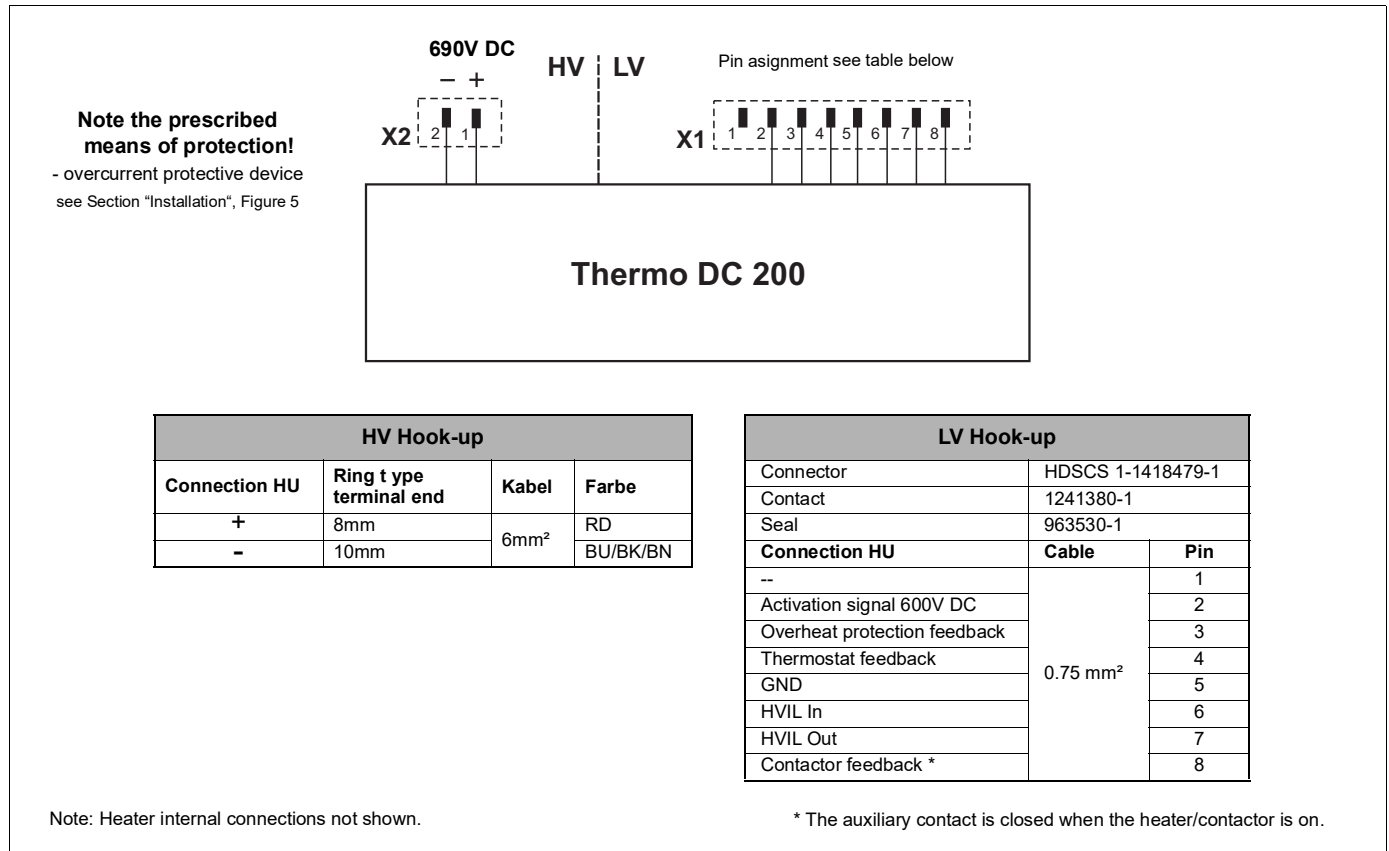

Figure 17: Anschlussplan Thermo DC 690V DC





---

Valeo Thermal Commercial Vehicles Germany GmbH  
Friedrichshafener Str. 7 - 82205 Gilching - Germany - Tel. +49 8105 7721-0 - [www.valeo-thermalbus.com](http://www.valeo-thermalbus.com)