



PARTS & SERVICE

Klimaanlage
Air conditioning system

Ersatzteil-Liste
Spare parts list



REVO®
Global

Inhalt/Content:

Übersicht / Overview	Bild/fig. 1
Komponenten Systemsteuerung / system control components	Bild/fig. 2
Haube / Cover	Bild/fig. 3
Verflüssiger, Axialgebläse / condenser, axial fan	Bild/fig. 4
Kältemittelsammler / refrigerant receiver	Bild/fig. 5
Gebläse, Expansionsventil links / blower, expansion valve LH side	Bild/fig. 6
Verrohrung, Komponenten KM-Anschluss rechts / piping, components for refrigerant connection at RH side	Bild/fig. 7
Komponenten / components	Bild/fig. 8
Verrohrung, Komponenten Wasser-Anschluss rechts / piping, components for water connection at RH side	Bild/fig. 9
Verrohrung, Komponenten Wasser-Anschluss links / piping, components for water connection at LH side	Bild/fig. 10
Klappenantrieb, Luftfilter / flap actuator, air filter	Bild/fig. 11
Kabelbäume / wiring harnesses	Bild/fig. 12
Normteile, Halbzeuge / standard parts, semi-finished parts	Seite/page 20

Notwendige Angaben zur schnellen Ersatzteilermittlung: / Required data for quick spare part identification:

- Klimaanlage Typ: z.B. REVO GLOBAL /
- A/C unit model: e.g. REVO GLOBAL
- Valeo-Identnummer: z.B. 11119691A
- Valeo ID: e.g. 11119691A
- Produktionsdatum: z.B. 20141024/
- Date of production: e.g. 20141024
- Seriennr.: z.B. 14182756/
- Serial no.: e.g. 14182756

 E1 10R-05 7418	
MADE IN TURKEY	
Model	Revo Global 250 R12 SC1000
Valeo ID	11119691A
Customer ID	
P COOLING / P HEATING	25kW / 27kW
VOLTAGE	24V
REFRIGERANT / OIL TYPE	R134a
	Water / Glycol
MAX. PRESSURE / A/C-r...	25 bar / 2 bar
Serial No./Date of Prod.	00000000 00000000
	
Year of Initiating	2022 2023 2024

REVO Global Varianten / REVO Global Variants

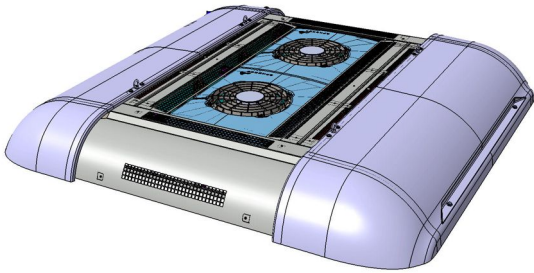

REVO Global 200

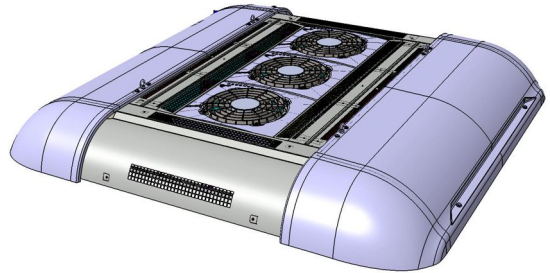

REVO Global 250

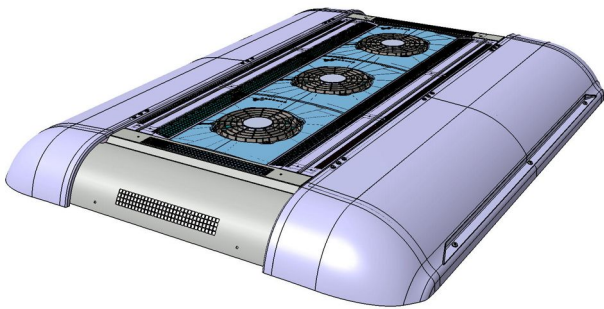

REVO Global 350

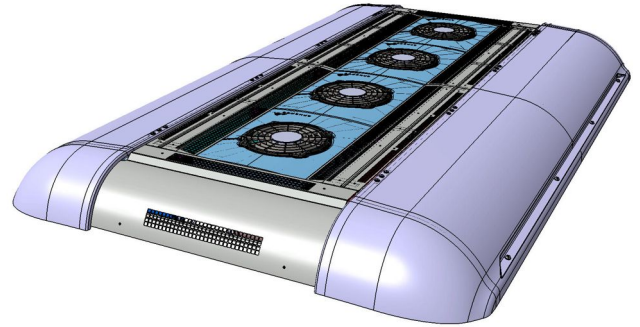

REVO Global 400

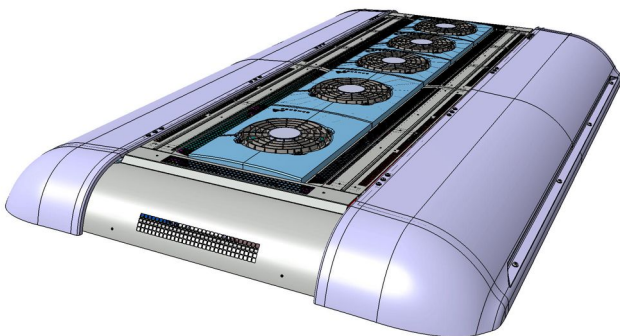

REVO Global 450

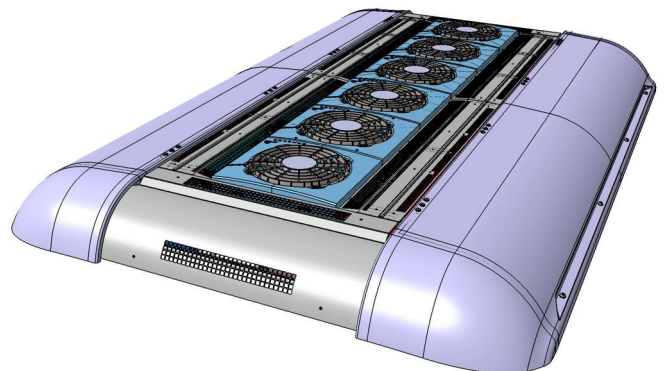

REVO Global 500

Technische Daten / Technical Data

REVO Global	200	250 / 250 R ³⁾	350 ¹⁾	400 / 400S	450	500
Max. Kälteleistung / cooling capacity max (kW)	22	25	33	39 / 41	43	47
Heizleistung / heating capacity (kW)*	30*	30*	35*	40*	40*	40*
Luftvolumenstrom / air flow (m ³ /h)	4600	4600	6900	6900 / 9200	9200	9200
Leistungsaufnahme bei voller Leistung / current consumption (A) at full performance	55	63	77	95 / 112	120	128
Axialgebläse / axial blowers	2	3	3	4	5	5
Radialgebläse / radial blowers	4	4	6	6 / 8	8	8
Max. Betriebstemperatur / max. operating Temperature (°C)	50°C (TM31) 51°C (TM21)	56°C (TM31) 52°C (FKX40/465)	52°C (FKX40/465)	54°C (FKX40/660)	54°C (FKX40/660) 55°C (FKX50/775) ²⁾ 57°C (FKX50/775) ²⁾	58°C (FKX50/775) ²⁾
Abmessungen LxBxH / measurement LxWxH (mm)	2100x1900x215	2100x1900x215	2500x1900x215	3000x1900x215	3000x1900x240	3000x1900x240
Gewicht / Weight (kg)	90	100	125	160	175	180
Kältemittel	R134a	R134a	R134a	R134a	R134a	R134a

* optional

¹⁾ Auf Anforderung / on demand

²⁾ abhängig vom Axialgebläse-Lieferanten / depending on supplier of axial blower

³⁾ Anlage / unit 111123793_

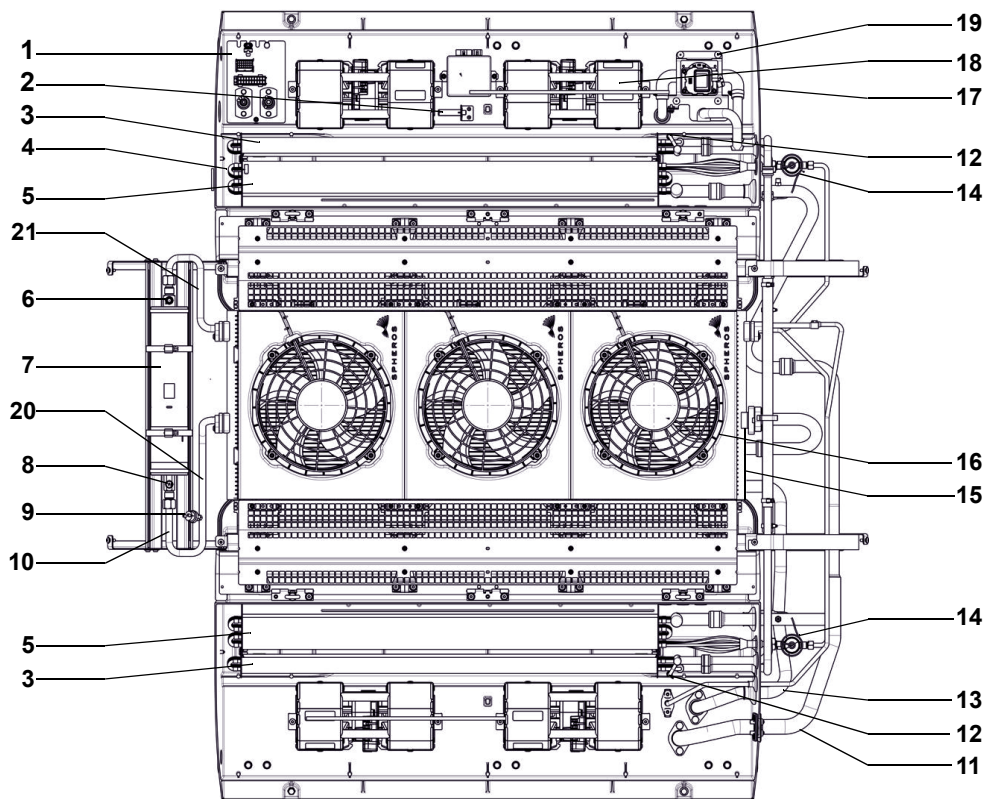

- 1 Elektrik-Schnittstelle
- 2 Temperatursensor
- 3 Heizteil
- 4 Eissensor zw. 1. und 2. Rohrreihe
- 5 Verdampfer
- 6 Schauglas
- 7 Sammler-Trockner
- 8 Kältemittel-Füllventil
- 9 Druckschalter
- 10 Absperrventil
- 11 Saugleitung
- 12 Entlüftung, Heizteil
- 13 Druckleitung
- 14 Expansionsventil
- 15 Verflüssiger
- 16 Axiallüfter, Verflüssiger
- 17 Position Typschild
- 18 Radialgebläse
- 19 Wasserventil
- 20 Sicherheitsventil
- 21 Magnetventil (nur RG200)

- 1 electrical interface
- 2 temperature sensor
- 3 heat exchanger
- 4 ice sensor betw. 1st and 2nd pipe row
- 5 evaporator
- 6 sight glass
- 7 collector-dryer
- 8 refrigerant charging valve
- 9 pressure switch
- 10 shut-off valve
- 11 suction pipe
- 12 air bleed, heater
- 13 pressure pipe
- 14 expansion valve
- 15 condenser
- 16 axial fan, condenser
- 17 position of type plate
- 18 radial fan
- 19 water valve
- 20 safety valve
- 21 solenoid valve (RG200 only)

REVO Global 250 R 11123793_ - Bild/fig. 1a

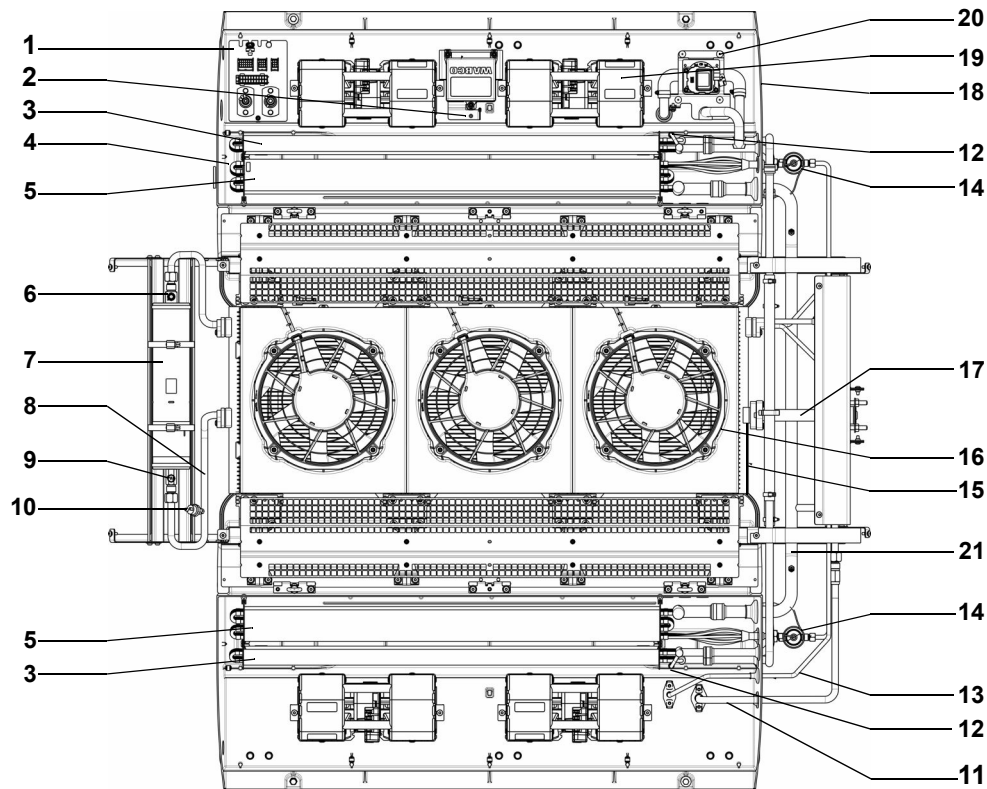

- 1 Elektrik-Schnittstelle
- 2 Temperatursensor
- 3 Heizteil
- 4 Eissensor zw. 1. und 2. Rohrreihe
- 5 Verdampfer
- 6 Schauglas
- 7 Sammler-Trockner
- 8 Sicherheitsventil
- 9 Kältemittel-Füllventil
- 10 Druckschalter
- 11 Sauganschluss, Frontbox
- 12 Entlüftung, Heizteil
- 13 Frontboxleitung
- 14 Expansionsventil
- 15 Verflüssiger
- 16 Axiallüfter, Verflüssiger
- 17 Druckleitung
- 18 Position Typschild
- 19 Radialgebläse
- 20 Wasserventil
- 21 Saugleitung

- 1 electrical interface
- 2 temperature sensor
- 3 heat exchanger
- 4 ice sensor betw. 1st and 2nd pipe row
- 5 evaporator
- 6 sight glass
- 7 collector-dryer
- 8 safety valve
- 9 refrigerant charging valve
- 10 pressure switch
- 11 suction connection, frontbox
- 12 air bleed, heater
- 13 frontbox pipe
- 14 expansion valve
- 15 condenser
- 16 axial fan, condenser
- 17 pressure pipe
- 18 position of type plate
- 19 radial fan
- 20 water valve
- 21 suction pipe

Normteile ab Pos. 100 siehe Seite 20
Standard parts

REVO Global - Bild 2/fig. 2

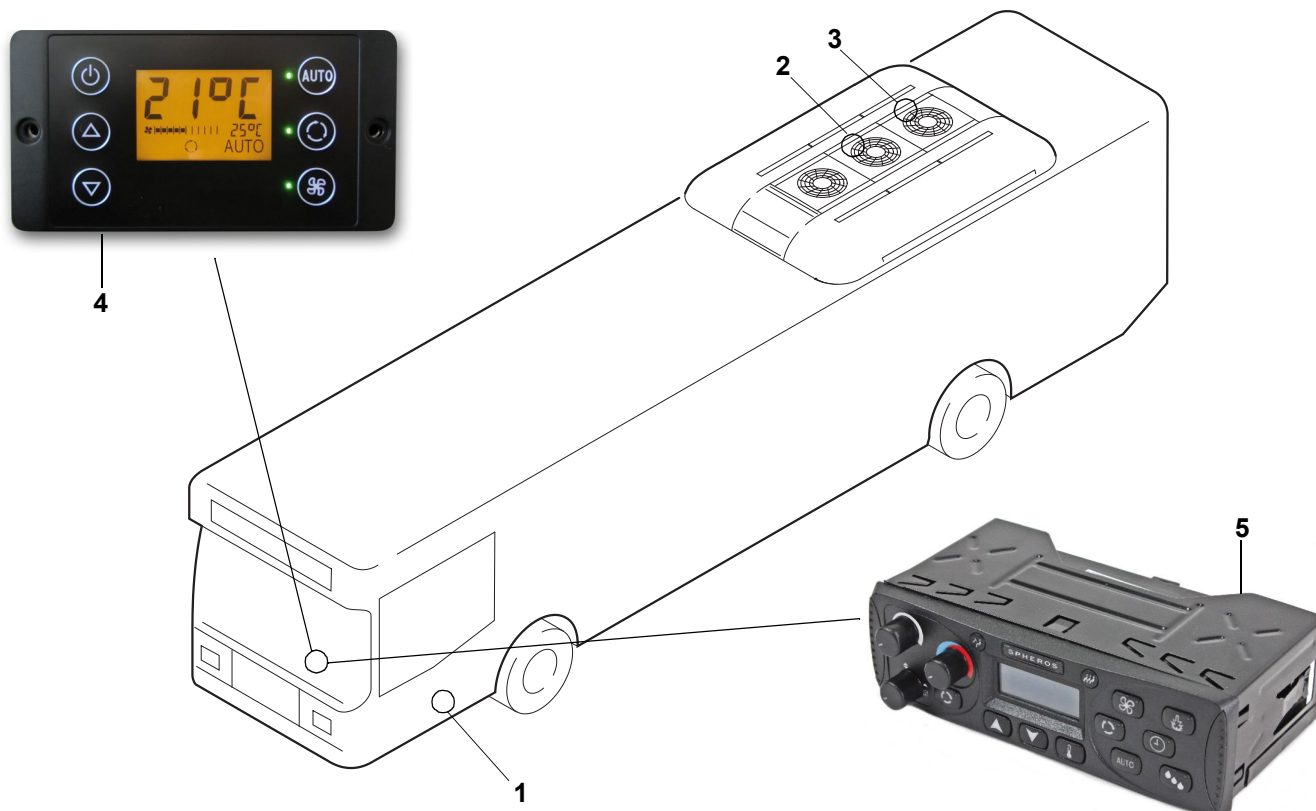

Pos./Item	Stück/Quantity REVO Global							Bestell-Nr./Part. no.	Benennung	Description	Bemerkung/Remarks
	200	250	250R	350	400	450	500				

Komponenten Systemsteuerung / system control components

1	1	1	1	1	1	1	1	11118004A	Temperaturfühler, aussen	temperature sensor, outside	
2	1	1	1	1	1	1	1	11118005A	Temperaturfühler, Raum	temperature sensor, room	
3	1	1	1	1	1	1	1	83186A	Temperaturfühler, Eis	temperature sensor, ice	
4	1	1	1	1	1	1	1	11122056D	Bedienteil SC600	control panel SC600	mit Heizen / with heating
4	1	1	1	1	1	1	1	11121143E	Bedienteil SC600	control panel SC600	nur Kühlen / cooling only
4	1	1	1	1	1	1	1	11121570A	Bedienteil SC600	control panel SC600	Scania India
5	1	1	1	1	1	1	1	11116930F	Bedienteil SC1000	control panel SC1000	Temsa
5 no fig.	1	1	1	1	1	1	1	11116929D	Unterstation SC1000	substation SC1000	

Normteile ab Pos. 100 siehe Seite 20
Standard parts from item no. 100 - see page 20

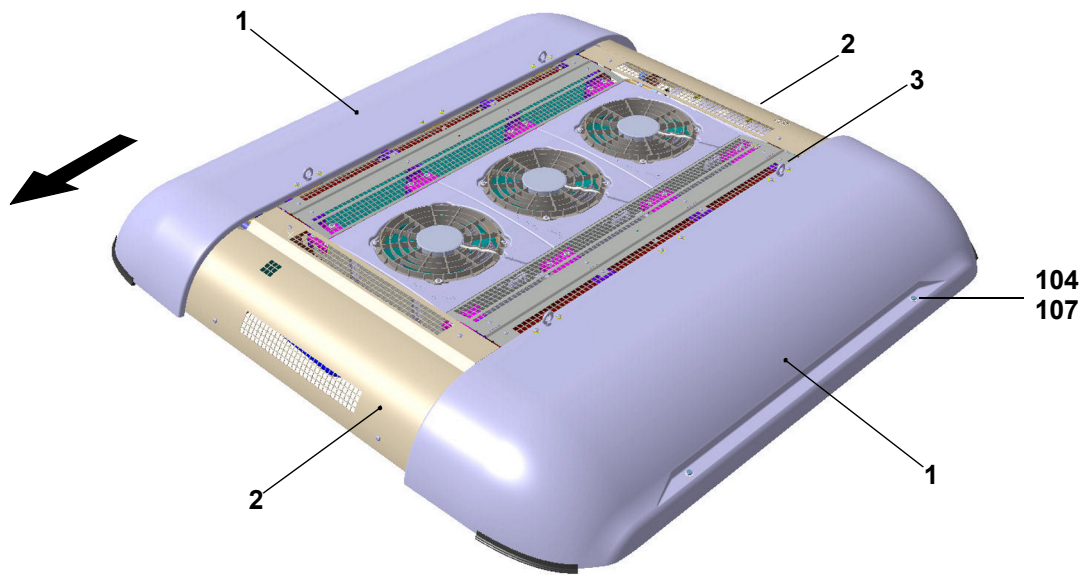

Pos./Item	Stück/Quantity REVO Global							Bestell-Nr./Part. no.	Benennung	Description	Bemerkung/Remarks
	200	250	250R	350	400	450	500				

Haube / cover

1	2	2	2					11119672C	Haube, re/li	cover, RH/LH	
1				2				TBD	Haube, re/li	cover, RH/LH	
1					2	2	2	11120271C	Haube, re/li	cover, RH/LH	
2	2	2	1	2	2	2	2	11119560C	Haube, hi/vo	cover, rear/front	für 250R nur vorn / for 250R front only
2			1					11123780B	Haube, hi	cover	
3	6	6	6	8	10	10	10	11119562B	Haubenscharnier	hinge, cover	
4 no fig.	2	2	2					11119609E	Dämmmatte, Haube 1360x518x13	insulating mat, cover 1360x518x13	RG 200, 250
4 no fig.				2				11120277A	Dämmmatte, Haube 1960x518x10	insulating mat, cover 1960x518x10	RG 350
4 no fig.					2	2	2	11120278C	Dämmmatte, Haube 2560x518x13	insulating mat, cover 2560x518x13	RG 400, 450, 500

Normteile ab Pos. 100 siehe Seite 20
Standard parts from item no. 100 - see page 20

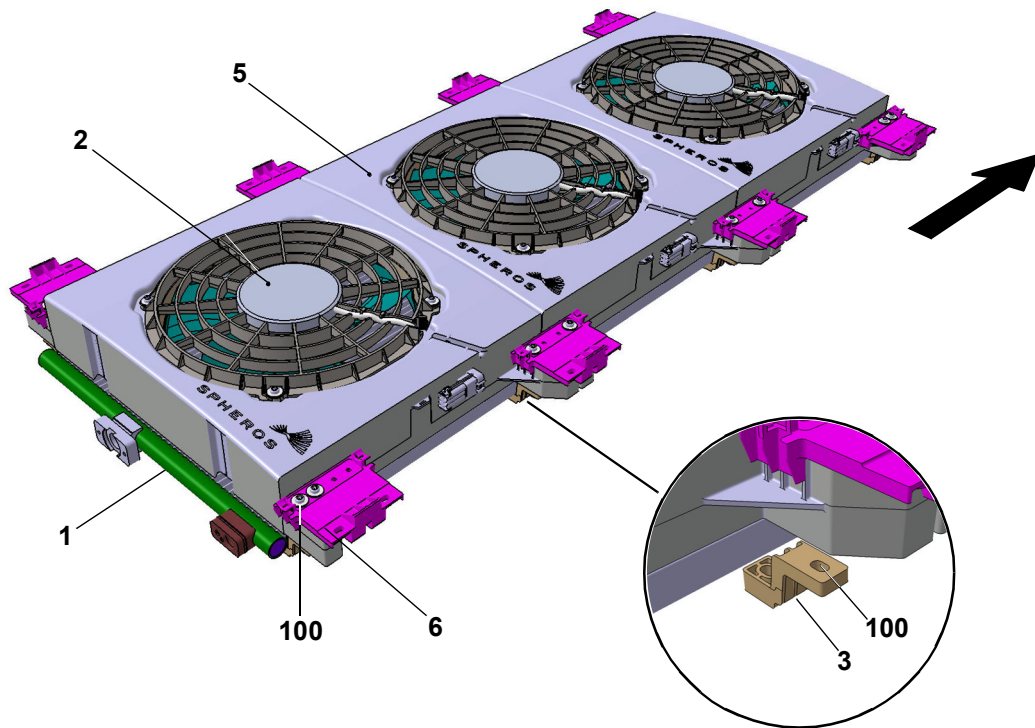

Pos./Item	Stück/Quantity REVO Global							Bestell-Nr./Part. no.	Benennung	Description	Bemerkung/Remarks
	200	250	250R	350	400	450	500				

Verflüssiger, Axialgebläse / condenser, axial fan

1	1	1	1					11122550A	Verflüssiger, 1300	Condenser, 1300	
1				1				11122551A	Verflüssiger, 1900	Condenser, 1900	
1					1			11122552A	Verflüssiger, 2500	Condenser, 2500	
1						1	1	11122554A	Verflüssiger, 2500	Condenser, 2500	
2	2	3	3	3	4	5	6	11122717D	Axialgebläse	axial fan	Gebläsemodul 11118714E bzw. 11118778E mitbestellen/order also axial fan module 11118714E or 11118778E
3	8	12	12	12	16	20	24	11114857B	Klammer, Verflüssiger	clamp, condenser	
5		3	3			3		11118778E	Axialgebläsemodul 400	axial fan module 400	
5	2			3	4	2	6	11118714E	Axialgebläsemodul 600	axial fan module 600	RG 200 - 400
6	6	8	8	8	10			11118716B	Halterung	attachment bracket	RG 200 - 400
6						12	14	11119646A	Halterung	attachment bracket	RG 450

Normteile ab Pos. 100 siehe Seite 20
Standard parts from item no. 100 - see page 20

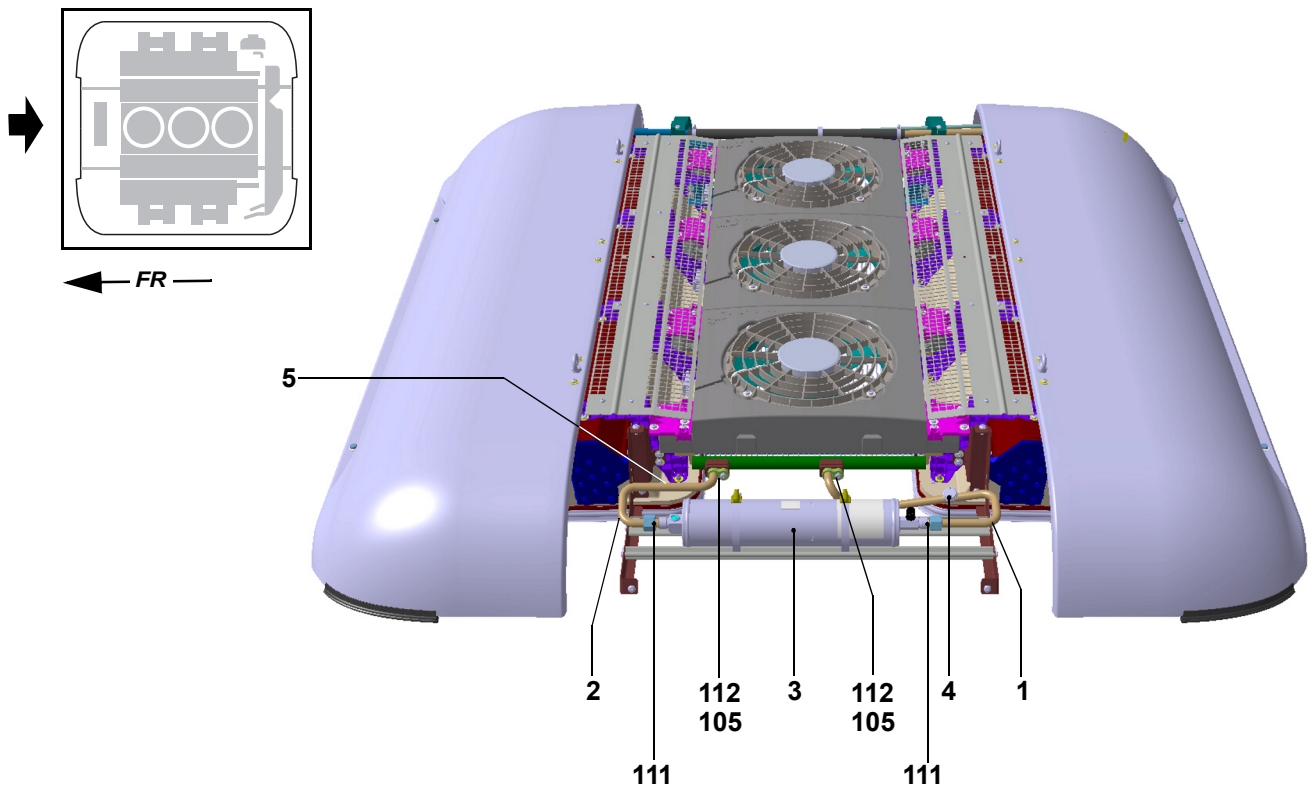

Pos./Item	Stück/Quantity REVO Global							Bestell-Nr./Part. no.	Benennung	Description	Bemerkung/Remarks
	200	250	250R	350	400	450	500				

Kältemittelsammler / refrigerant receiver

1	1	1	1	1	1			1118997C	Leitung, Verflüssiger - Sammler	line, condenser - receiver	
1						1	1	11120293A	Leitung, Verflüssiger - Sammler	line, condenser - receiver	
2	1	1	1	1	1			1118998B	Leitung, Sammler - Unterkühler	line, receiver-super cooler	
2						1	1	11120294A	Leitung, Sammler - Unterkühler	line, receiver-super cooler	
2	1							11138093A	Leitung, Sammler - Unterkühler	line, receiver-super cooler	RG200 mit Magnetventil with solenoid valve
3	1	1	1	1	1	1		11123774A	Sammler-Trockner	receiver-dryer	
4	1	1	1	1	1	1		11114982C	Druckschalter	pressure switch	
5	1							1102620B	Magnetventil	solenoid valve	RG200 enthalten in 11138093A contained in 11138093A

Normteile ab Pos. 100 siehe Seite 20
Standard parts from item no. 100 - see page 20

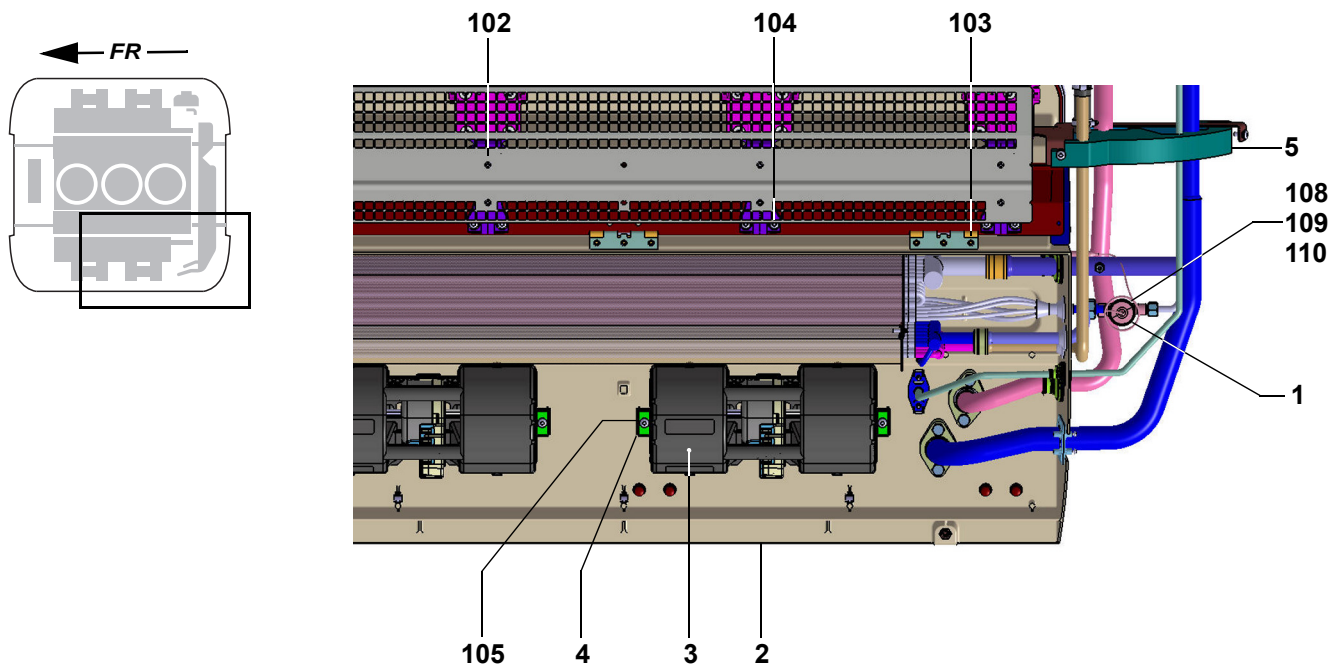

Pos./Item	Stück/Quantity REVO Global							Bestell-Nr./Part. no.	Benennung	Description	Bemerkung/Remarks
	200	250	250R	350	400	450	500				

Gebläse, Expansionsventil / Blower, expansion valve

1	2	2	2	2	2			11119611B	Expansionsventil	expansion valve
1						2	2	11117523B	Expansionsventil	expansion valve
2	2	2	2					11119953A	Dichtprofil, Dach	sealing profile, roof
2				2				11119954A	Dichtprofil, Dach	sealing profile, roof
2					2	2	2	11119955A	Dichtprofil, Dach	sealing profile, roof
3	4	4	4	3	8	8	8	11120703B	Gebläse, Doppelradial	fan, double radial
4	8	8	8	12	16	16	16	1102026C	Klammer, Gebläse	clamp, fan
5	2	2	2	2	2	2	2	11119483A	Halterung, Rohr	support, pipe
9 no fig.	4	4	4	4	4	4	4	11114970A	Stutzen, Kondenswasser	stud, condensation

Normteile ab Pos. 100 siehe Seite 20
Standard parts from item no. 100 - see page 20

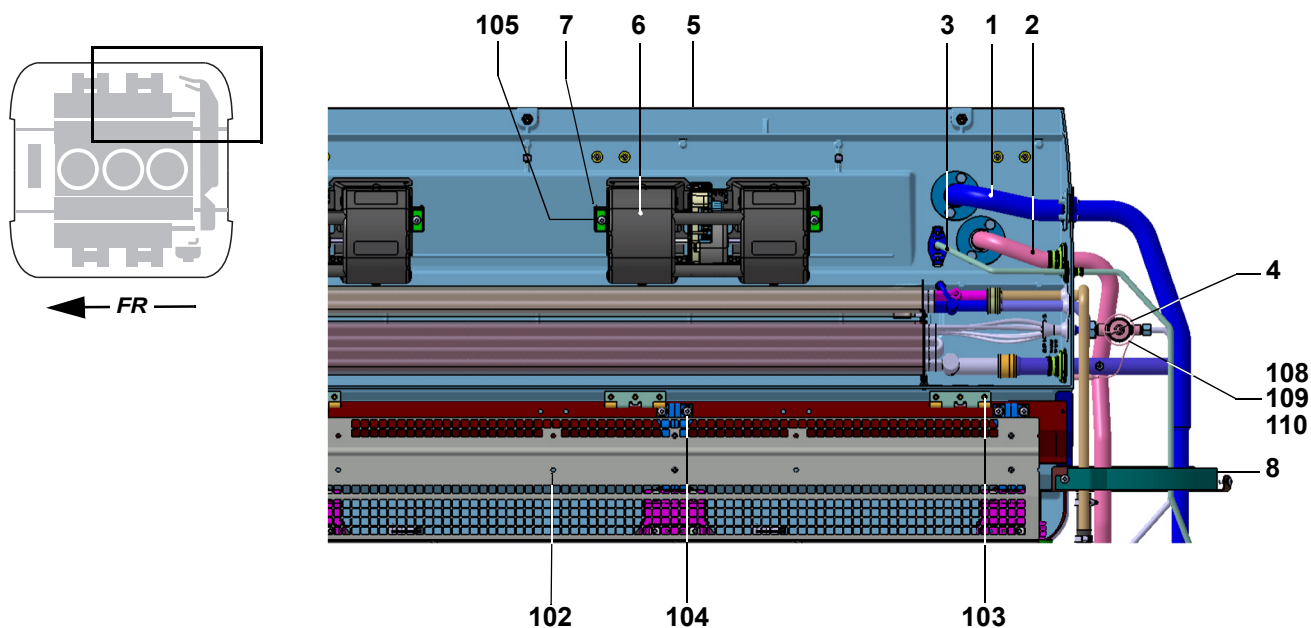

Pos./Item	Stück/Quantity REVO Global							Bestell-Nr./Part. no.	Benennung	Description	Bemerkung/Remarks
	200	250	250R	350	400	450	500				

Verrohrung, Komponenten KM-Anschluss rechts / piping, components for refrigerant connection at RH side

1	1	1	1	1	1	1	1	11119820C	Saugleitung 1, rechts	suction line 1, right	ohne Abdichtung Rohrdurchführung Id.No. 11121305A/ w/o sealing flange system id.no. 11121305A Siehe auch Serviceinformation „Reparaturanweisung REVO“, Valeo Service-Koffer (LOK-RING) (Pos. 119) notwendig / See also service information "REVO Repair instruction", Valeo service case (LOK-RING) (item 119) required
1b					1			11120836C	Saugleitung 1, rechts für REVO Global 400 breite Version	suction line 1, right for REVO Global 400 wide version	
2	1	1	1	1	1	1	1	11119822B	Druckleitung 1, rechts	pressure line 1, right	Siehe auch Serviceinformation „Reparaturanweisung REVO“, Valeo Service-Koffer (LOK-RING) (Pos. 119) notwendig / See also service information "REVO Repair instruction", Valeo service case (LOK-RING) (item 119) required
3	1	1	1	1	1	1	1	11119823B	Fronboxleitung 1, rechts	frontbox line 1, right	
4	2	2	2	2	2			11119611B	Expansionsventil	expansion valve	
4						2	2	11117523B	Expansionsventil	expansion valve	
5	2	2	2					11119953A	Dichtprofil, Dach	sealing profile, roof	
5				2				11119954A	Dichtprofil, Dach	sealing profile, roof	
5					2	2	2	11119955A	Dichtprofil, Dach	sealing profile, roof	
6	4	4	4	3	8	8	8	11120703B	Gebälse, Doppelradial	fan, double radial	
7	8	8	8	12	16	16	16	1102026C	Klammer, Gebläse	clamp, fan	
8	2	2	2	2	2	2	2	11119483A	Halterung, Rohr	support, pipe	
9	4	4	4	4	4	4	4	11114970A	Stutzen, Kondenswasser	stud, condensation	
no fig.											

Normteile ab Pos. 100 siehe Seite 20
Standard parts from item no. 100 - see page 20

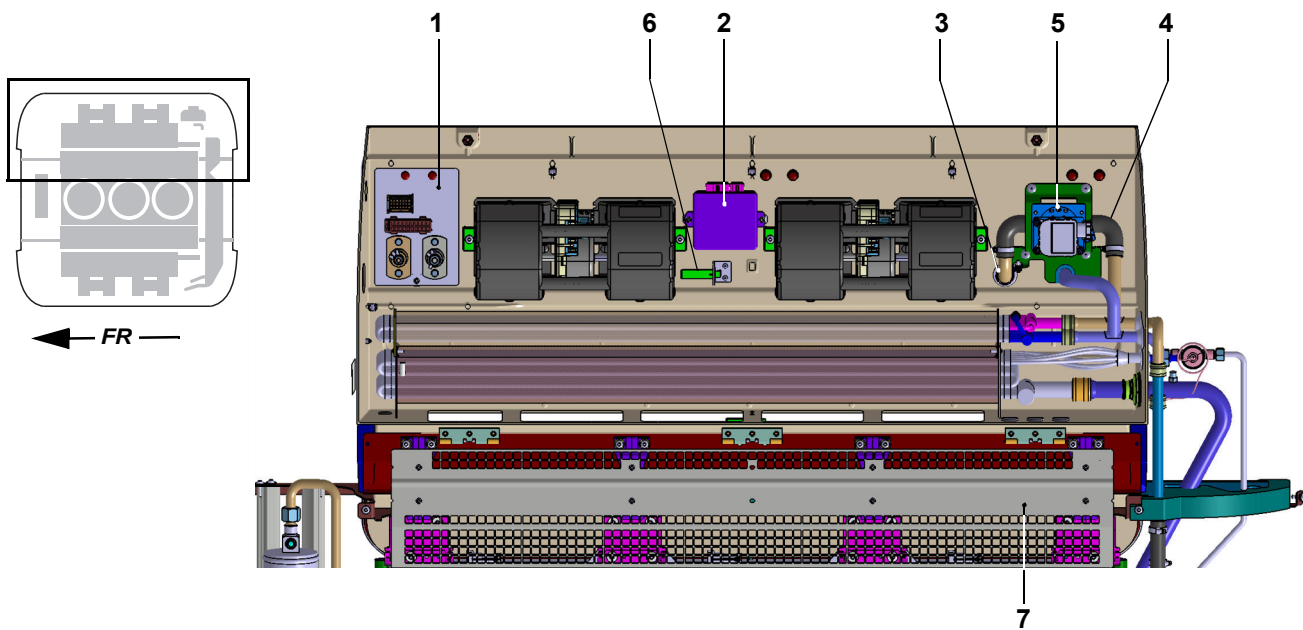

Pos./Item	Stück/Quantity REVO Global							Bestell-Nr./Part. no.	Benennung	Description	Bemerkung/Remarks
	200	250	250R	350	400	450	500				

Komponenten / components

1	1	1		1				11119220E	Kabelbaum	wiring harness	RG 200 - 350
1					1	1	1	11119730C	Kabelbaum	wiring harness	RG 400 - 450, 500
1			1					11123680B	Kabelbaum	wiring harness	
2	1	1		1	1	1	1	11116929D	Unterstation, SC1000	substation, SC1000	für SC 1000 Steuerung/ for SC 1000 control
2			1					68012B	Unterstation	substation	
3	1	1	1	1	1	1	1	11119018B	Wasserrohr, D22, re/li	water pipe, D22, RH/LH	
4	2	2	2	2	2	2	1	11119622A	Formschlauch 90°, D22	water hose, elbow, D22	
5	1	1	1	1	1	1	1	11119561C	Wasserventil	water valve	
6	1	1		1	1	1	1	11118005A	Temperatursensor, innen, Luftauslass	temperature sensor, room, outlet air	
6			1					83164A	Temperatursensor	temperature sensor	
7	2	2	2		4	4	4	11119590D	Laubgitter	leaf guard	RG 200, 250, 400, 450, 500
7				2				11119851A	Laubgitter	leaf guard	Rg 350

Normteile ab Pos. 100 siehe Seite 20
Standard parts from item no. 100 - see page 20

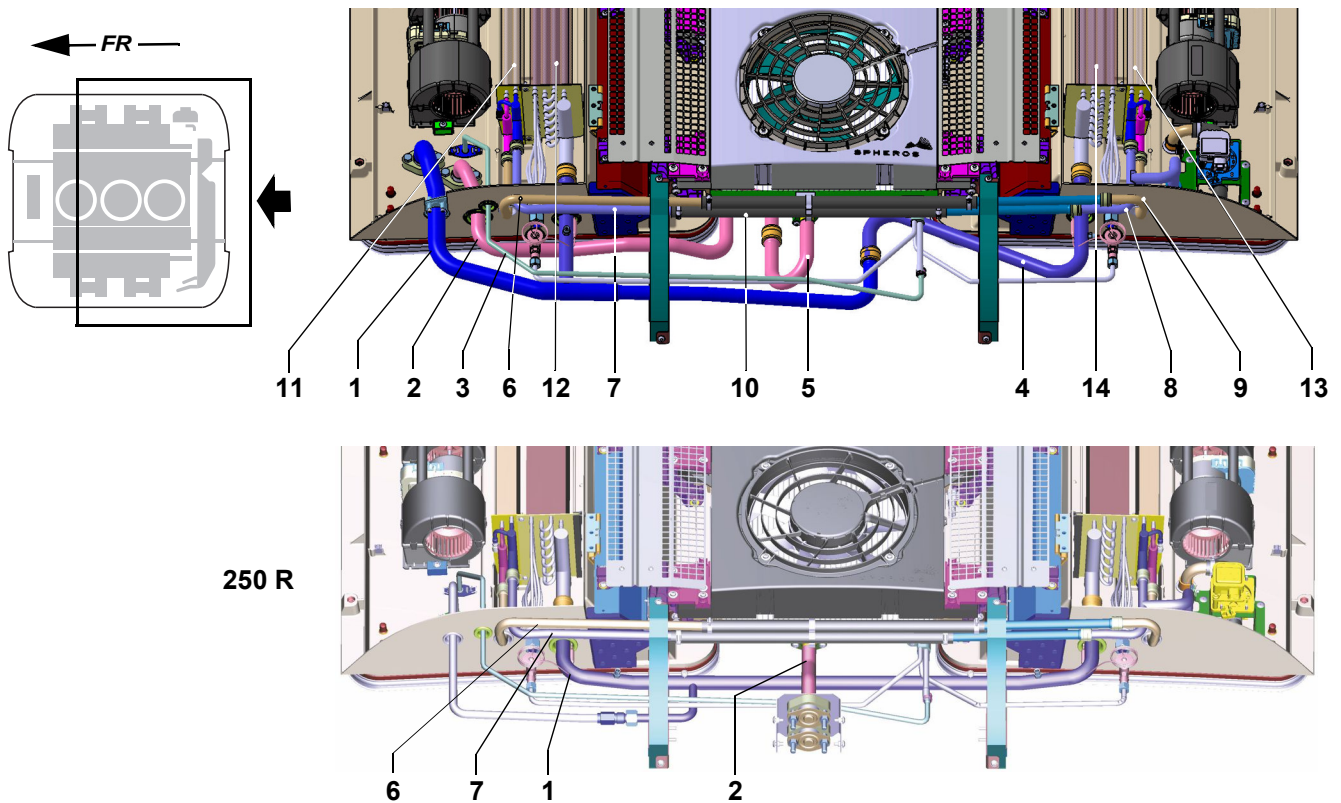

Pos./Item	Stück/Quantity REVO Global							Bestell-Nr./Part. no.	Benennung	Description	Bemerkung/Remarks
	200	250	250R	350	400	450	500				

Verrohrung, Komponenten Wasser-Anschluss rechts / piping, components for water connection at RH side

1	1	1		1	1	1	1	11119014D	Saugleitung 1, links	suction line 1, left	Siehe auch Serviceinformation „Reparaturanweisung REVO“, Spheros Service-Koffer (LOKRING) (Pos. 119) notwendig / See also service information “REVO Repair instruction”, Spheros service case (LOKRING) (item 119) required
1			1					11123779A	Saugleitung Anschluss mitte	suction pipe connection MID	
2	1	1		1	1	1	1	11119012C	Druckleitung 1, links	pressure line 1, left	
2			1					11123778B	Druckleitung Anschluss mitte	pressure line connection MID	
3	1	1	1	1	1	1	1	11119017C	Fronboxleitung 1, links	frontbox line 1, left	
4	1	1		1	1	1	1	11119013B	Saugleitung, zentral	suction line, centrally	
5	1	1		1	1			11118998B	Druckleitung, zentral	pressure line, centrally	
5						1	1	11121666A	Druckleitung, zentral	pressure line, centrally	
6	1	1		1	1	1	1	11119032B	Wasserleitung, Vorlauf, li	water line, flow, LH	
6			1					11119072B	Wasserleitung, Vorlauf, li	water line, flow, LH	
7	1	1		1	1	1	1	11119072B	Wasserleitung, Rücklauf, li	water line, return, LH	
7			1					11119032B	Wasserleitung, Rücklauf, li	water line, return, LH	
8	1	1	1	1	1	1	1	11119019B	Wasserleitung, Rücklauf, re	water line, return, RH	
9	1	1	1	1	1	1	1	11119020B	Wasserleitung, Vorlauf, re	water line, flow, RH	

Normteile ab Pos. 100 siehe Seite 20
Standard parts from item no. 100 - see page 20

REVO Global - Bild 9a/fig. 9a

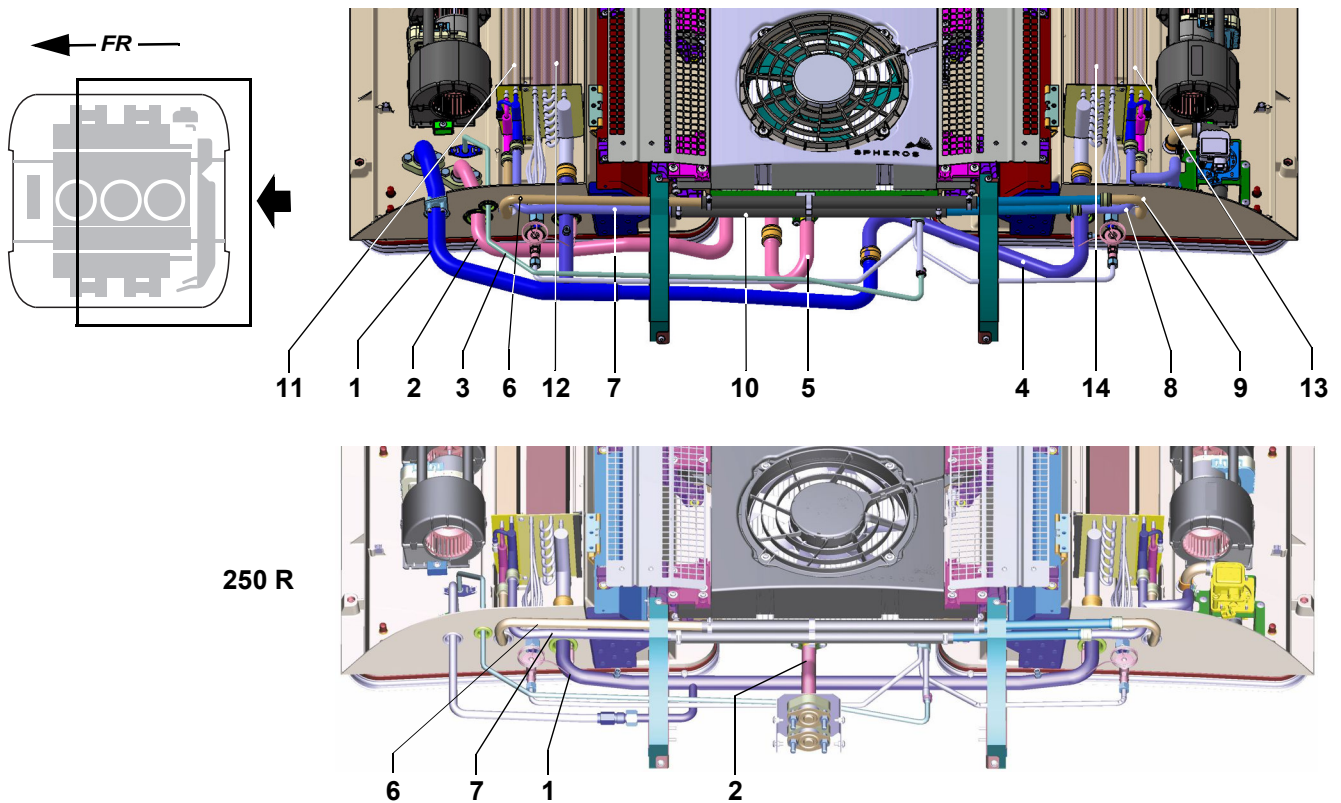

Pos./ Item	Stück/Quantity REVO Global							Bestell-Nr./ Part. no.	Benennung	Description	Bemerkung/Re- marks
	200	250	250R	350	400	450	500				

Verrohrung, Komponenten Wasser-Anschluss rechts / piping, components for water connection at RH side

10	2	2	2	2	2	2	2	11119987A	Wasserschlauch, D18	water hose, D18
11	1	1	1					11118737A	Wärmetauscher, li, 1000	heat exchanger, LH, 1000
11				1				11114352D	Wärmetauscher, li, 1500	heat exchanger, LH, 1500
11					1	1	1	11114384C	Wärmetauscher, li, 2020	heat exchanger, LH, 2020
12	1	1	1					11118733A	Verdampfer, li, 1000	evaporator, LH, 1000
12				1				11114350E	Verdampfer, li, 1500	evaporator, LH, 1500
12					1	1	1	11114351E	Verdampfer, li, 2020	evaporator, LH, 2020
13	1	1	1					11118738A	Wärmetauscher, re, 1000	heat exchanger, RH, 1000
13				1				11114311D	Wärmetauscher, re, 1500	heat exchanger, RH, 1500
13					1	1	1	11114383C	Wärmetauscher, re, 2020	heat exchanger, RH, 2020
14	1	1	1					11118734A	Verdampfer, re, 1000	evaporator, RH, 1000
14				1				11114349E	Verdampfer, re, 1500	evaporator, RH, 1500
14					1	1	1	11114382E	Verdampfer, re, 2020	evaporator, RH, 2020

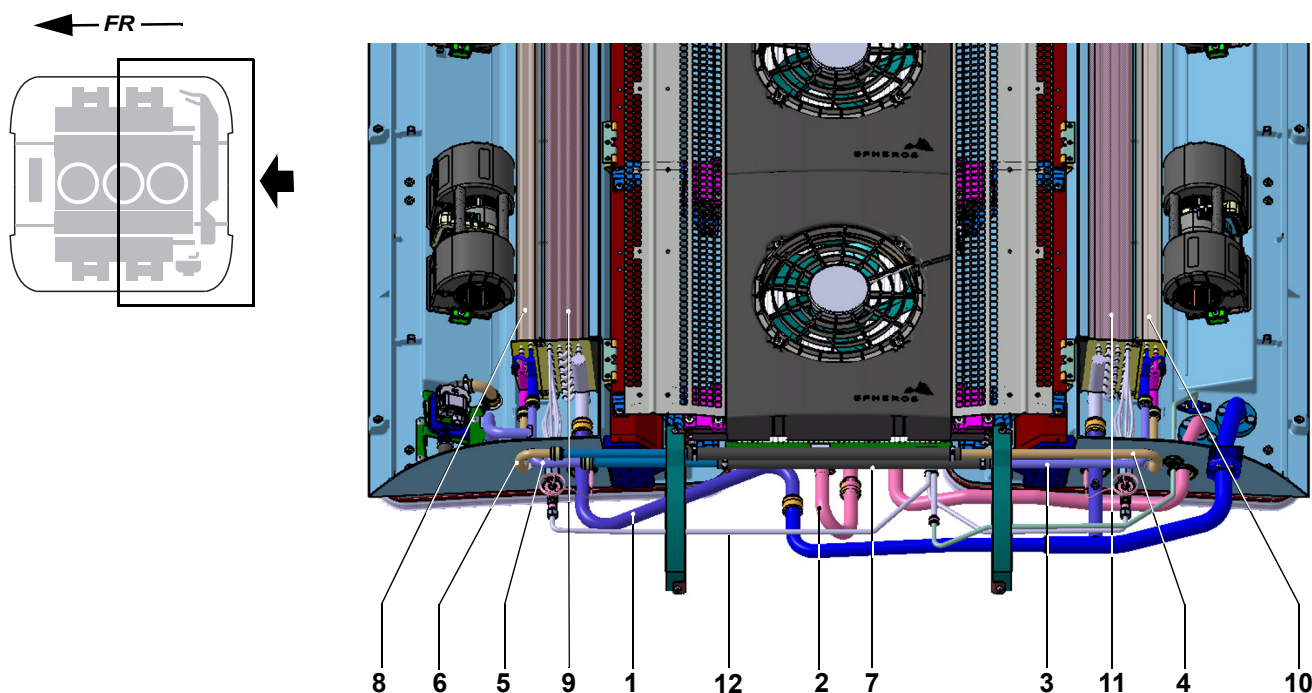

Pos./Item	Stück/Quantity REVO Global							Bestell-Nr./Part. no.	Benennung	Description	Bemerkung/Remarks
	200	250	250R	350	400	450	500				

Verrohrung, Komponenten Wasser-Anschluss links / piping, components for water connection at LH side

1	1	1	1	1	1	1	1	11119013B	Saugleitung, zentral	suction line, centrally	
2	1	1	1	1	1			11118998B	Druckleitung, zentral	pressure line, centrally	
2						1	1	11121666A	Druckleitung, zentral	pressure line, centrally	
3	1	1	1	1	1	1	1	11119072B	Wasserleitung, Rücklauf, re	water line, return, RH	
4					1			11119825A	Wasserleitung, Vorlauf, re	water line, flow, RH	
5					1			11119826A	Wasserleitung, Rücklauf, li	water line, return, LH	
6					1			11119831A	Wasserleitung, Vorlauf, li	water line, flow, LH	
7	2	2	2	2	2	2	2	11119987A	Wasserschlauch, D18	water hose, D18	
8	1	1	1					11118737A	Wärmetauscher, li, 1000	heat exchanger, LH, 1000	
8				1				11114352D	Wärmetauscher, li, 1500	heat exchanger, LH, 1500	
8					1	1	1	11114384C	Wärmetauscher, li, 2020	heat exchanger, LH, 2020	
9	1	1	1					11118733A	Verdampfer, li, 1000	evaporator, LH, 1000	
9				1				11114350E	Verdampfer, li, 1500	evaporator, LH, 1500	
9					1	1	1	11114351E	Verdampfer, li, 2020	evaporator, LH, 2020	
10	1	1	1					11118738A	Wärmetauscher, re, 1000	heat exchanger, RH, 1000	
10				1				11114311D	Wärmetauscher, re, 1500	heat exchanger, RH, 1500	
10					1	1	1	11114383C	Wärmetauscher, re, 2020	heat exchanger, RH, 2020	

Pos./Item	Stück/Quantity REVO Global							Bestell-Nr./ Part. no.	Benennung	Description	Bemerkung/Re- marks
	200	250	250R	350	400	450	500				
11	1	1	1					11118734A	Verdampfer, re, 1000	evaporator, RH, 1000	
11				1				11114349E	Verdampfer, re, 1500	evaporator, RH, 1500	
11					1	1	1	11114351E	Verdampfer, re, 2020	evaporator, RH, 2020	
12	1	1	1	1	1	1	1	11119015B	Flüssigkeitsleitung	fluid pipe	

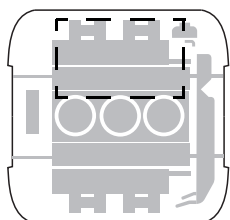

← FR →

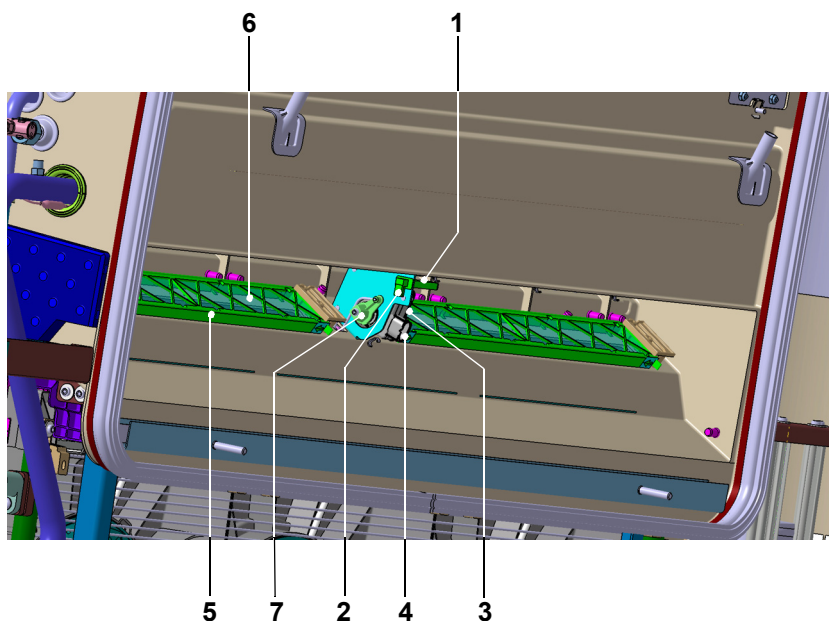

Pos./Item	Stück/Quantity REVO Global							Bestell-Nr./Part. no.	Benennung	Description	Bemerkung/Remarks
	200	250	250R	350	400	450	500				

Klappenantrieb, Luftfilter / flap actuator, air filter

1	1	1		1	1	1		11118005A	Temperatursensor	temperature sensor	
1 no fig.			1					83164A	Temperatursensor	temperature sensor	
2	2	2	2	2	2	2		11119232C	Anschlussadapter, Temperatursensor	wiring adapter, temperature sensor	
3	2	2	2	2	2	2		11120134A	Klappenantrieb, Frischluft	flap actuator, fresh air	
4	2	2	2	2	2	2		11121986B	Anschlussadapter, Klappenantrieb	wiring adapter, flap actuator	
5	4	4	4	6	6	6		11118718B	Gehäuse, Luftfilter	cartridge, air filter	
6	4	4	4	6	6	6		11119607A	Luftfilter	air filter	
7	2	2		2	2	2		11121514A	Exzenter-Klappeneinheit	excenter flap unit	
7			2					11140388A	Exzenter-Klappeneinheit	excenter flap unit	

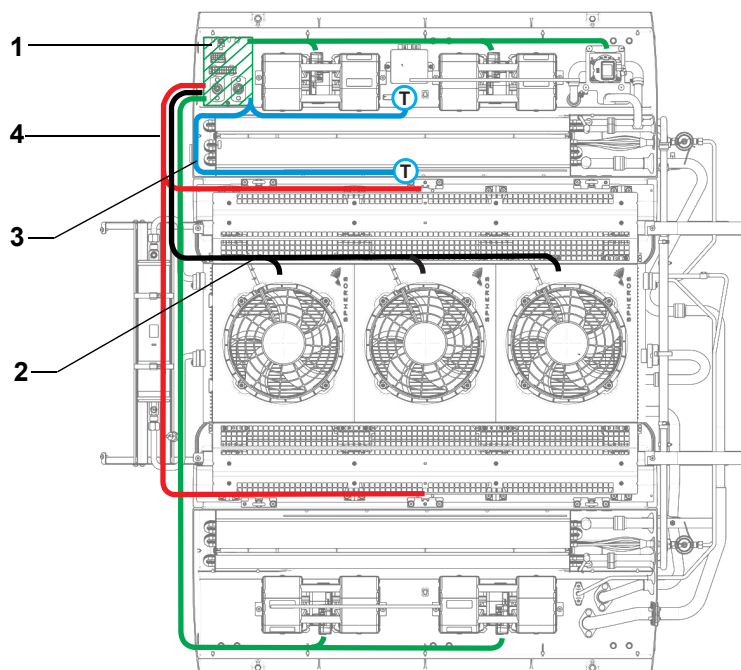

Pos./Item	Stück/Quantity REVO Global							Bestell-Nr./Part. no.	Benennung	Description	Bemerkung/Remarks
	200	250	250R	350	400	450	500				

Kabelbäume / wiring harnesses

1	1	1		1				11119220E	Kabelbaum, Lüfter	wiring harness, fans	mit Anschlussplatte/ with terminal plate RG 200 - 350
1			1					11123680B	Kabelbaum, Lüfter	wiring harness, fans	mit Anschlussplatte RG 200 - 350 und Sensoren / with terminal plate RG 200 - 350 and sensors
1					1	1	1	11119730C	Kabelbaum, Lüfter	wiring harness, fans	mit Anschlussplatte/ with terminal plate RG 400 - 450
2	1	1		1				11119221C	Kabelbaum, Verflüssiger	wiring harness, condenser	RG 200 - 350
2			1					11142458A	Kabelbaum, Verflüssiger	wiring harness, condenser	
2					1	1		11120211A	Kabelbaum, Verflüssiger	wiring harness, condenser	RG 400 - 450
2							1	11120345A	Kabelbaum, Verflüssiger	wiring harness, condenser	RG 500
2		1						11138176A	Kabelbaum mit Magnetventil	wiring harness with solenoid valve	RG 250
2					1	1		11138099A	Kabelbaum	wiring harness	RG 400, 450 SC600
3	2	2		2	2	2	2	11119232C	Kabelbaum, Sensoren	wiring harness, sensors	für 205R enthalten in Pos. 1, 11123680B / for 205R included in item 1, 11123680B
4	2	2		2	2	2	2	11119330C	Kabelbaum, Frischluft	wiring harness, fresh air	
4			1					11121986B	Kabelbaum, Frischluft	wiring harness, fresh air	

Pos./Item	Stück/Quantity REVO Global							Bestell-Nr./ Part. no.	Benennung	Description	Bemerkung/Remarks
	200	250	250R	350	400	450	500				

Normteile, Halbzeuge / Standard parts, semi-finished parts

100								11115529B	Schraube, Typ DS WN5451, 60x22	screw, type DS WN5451, 60x22	
101								11115527A	Schraube, Typ DS WN5451, 40x16	screw, type DS WN5451, 40x16	
102								11119729A	Schraube, Typ DS WN5451, 50x16	screw, type DS WN5451, 50x16	
103								11118281A	Schraube Torx M6x16	screw Torx head, M6x16	in Verbindung mit Pos. 100 / together with item 100
104								11120368A	Schraube Torx M6x20	screw Torx head, M6x20	Verbindung Verdampfer/ Heizteil / connection evaporator/heating ele- ment
105								11115563A	Schraube Torx, M6x25	screw Torx head, M6x25	
106								11124958A	Schraube, Hauben M8x30	screw, cover M8x30	
107								11115684A	Scheibe, VA	washer, VA, 8.4x20x1.5	wird zus. mit Pos. 106 verbaut / installed to- gether with item 106
108								80812A	O-Ring, 7.65 x 1.78, R134A-beständig	O-Ring, 7.65 x 1.78, R134A-resistant	zw. Expansionsventil u. Flüssigkeitsleitg. / btw. expansion valve a. liquid line
109								80640A	O-Ring, 10.6 x 1.78, R134A-beständig	O-Ring, 10.6 x 1.78, R134A-resistant	zw. Expansionsventil u. Rohr vom WT / btw. ex- pansion valve a. pipe from heat exchanger
110								1103522A	O-Ring, 4.48 x 1.78, R134A-beständig	O-Ring, 4.48 x 1.78, R134A-resistant	zw. Expansionsventil u. Ausgleichsleitg. 2x / btw. expansion valve a. com- pensation line, 2 times
111								80641A	O-Ring, 14 x 1.78, R134A-beständig	O-Ring, 14 x 1.78, R134A-resistant	Sammler/receiver
112								11117038A	O-Ring, 11 x 2.5, R134A-beständig	O-Ring, 14 x 1.78, R134A-resistant	zw. Rohrgruppe u. Sammler / btw. pipe groups a. receiver
113								69052A	O-Ring, 26 x 2, R134A-beständig	O-Ring, 14 x 1.78, R134A-resistant	zw. Verflüssigeranschl. u. Leitg. Verfl.-Trockner / btw. condenser a. con- denser - drier line
114 - 118											
119 no fig.								11117080A	Service-Koffer LOKRING	service bag LOKRING	
120 no fig.								11116888A	LOKRING Kupplung, Ø 12	LOKRING coupling, Ø 12	
121 no fig.								11117849A	LOKRING Kupplung, Ø 16	LOKRING coupling, Ø 16	
122 no fig.								11116889A	LOKRING Kupplung, Ø 18	LOKRING coupling, Ø 18	
123 no fig.								11116890A	LOKRING Kupplung, Ø 28	LOKRING coupling, Ø 28	
124 no fig.								11115842B	LOKPREP 65G	LOKPREP 65G	Dichtmittel / sealing material, 15 ml

Stückzahl nach Bedarf / Quantity as required

