

REVO[®]

Maintenance and service schedule

Table of Contents

1	System overview REVO	3
2	Torque Specification	4
3	Maintenance	5
4	Maintenance and service plan	6

Dear customer,

thank you very much for purchasing a Valeo air conditioning system. We would like to congratulate you to this step.

We developed and manufactured this system according to newest technological aspects to offer highest quality and performance. Among others, the refrigeration circuit is manufactured to 99% from aluminum to minimize system weight. Aluminum used as well as the materials of the remaining components support a complete system life cycle. This applies for normal operation under common environmental conditions.

When used under environmental conditions with increased share of aggressive materials in the air, such as salt, phosphate or ammonia, corrosion may occur. Corrosion may occur, as the system components are not designed for such operating conditions. Furthermore, it must be observed that similar corrosion aspects may occur, if the system is not cleaned properly, e.g. using compressed or corrosion supporting substances or additives. Valeo shall not be liable for any damage caused by corrosion due to circumstances described above, as it does not present missing, but committed system features, or an error at time of system delivery. This shall apply for direct corrosion damage as well as for possible secondary damage. Regular system maintenance and care can help to early detect possible problem locations and to correct them prior to occurrence of substantial damage patterns.

Yours sincerely, Valeo Thermal Commercial Vehicles Germany GmbH

1 System overview

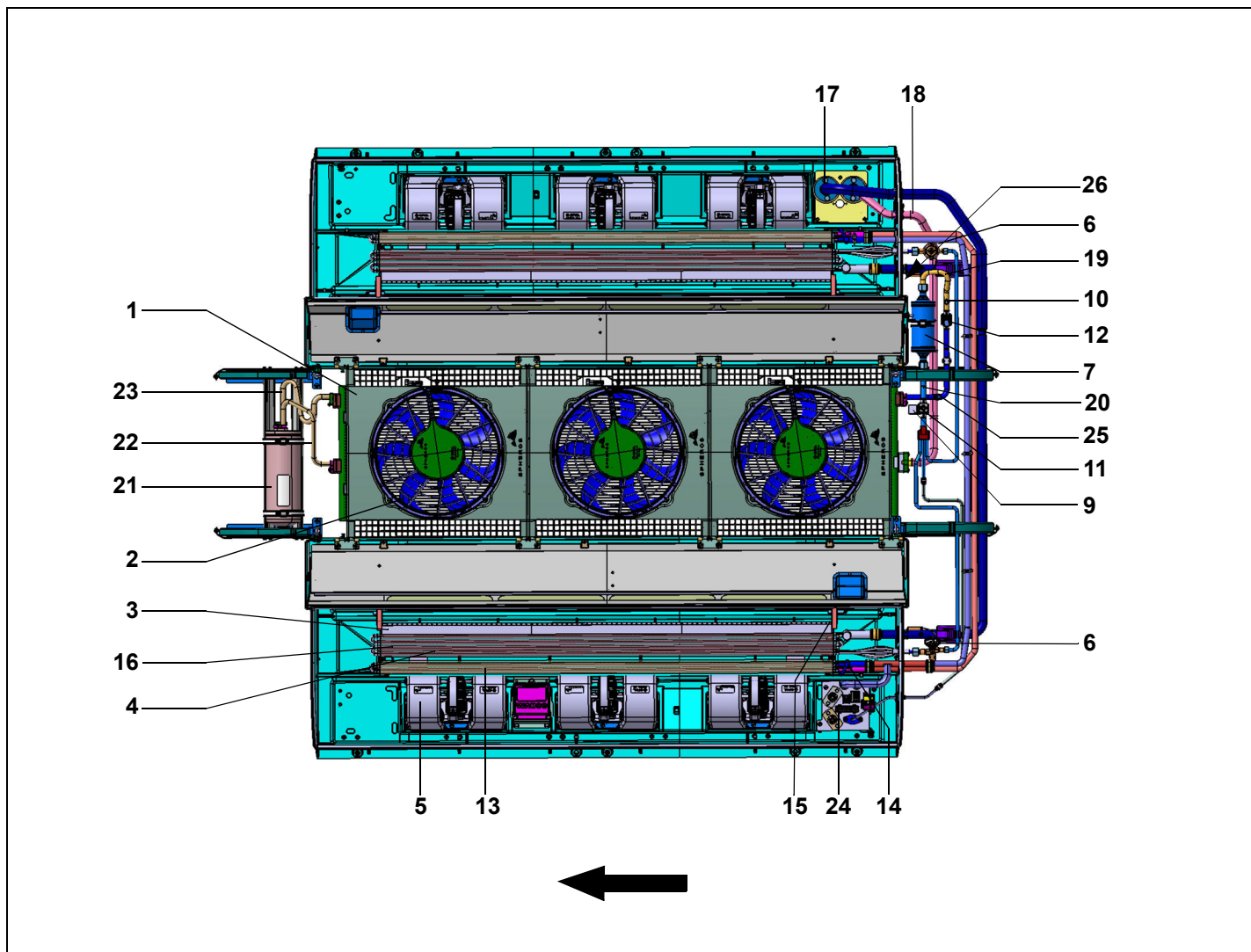

- | | | | |
|----|--|----|--|
| 1 | condenser | 14 | vent valve, heat exchanger |
| 2 | fan, condenser | 15 | actuation motor, flap, fresh air / circulating air |
| 3 | filter, fresh air / circulating air | 16 | thermostat, icing protection |
| 4 | evaporator | 17 | pressure line |
| 5 | fan, evaporator | 18 | suction line |
| 6 | expansion valve | 19 | refrigerant line, filter drier - condenser |
| 7 | filter drier | 20 | refrigerant line, filter drier - evaporator |
| 8 | pressure switch, fan, condenser (50% / max.) | 21 | refrigerant collector |
| 9 | service shut-off valve | 22 | refrigerant line, condenser - refrigerant collector |
| 10 | service interface | 23 | refrigerant line, super cooler - refrigerant collector |
| 11 | sight glass | 24 | electrical interface with fuses |
| 12 | solenoid valve | 25 | over pressure valve |
| 13 | heat exchanger | 26 | model plate |

2 Torque Specification

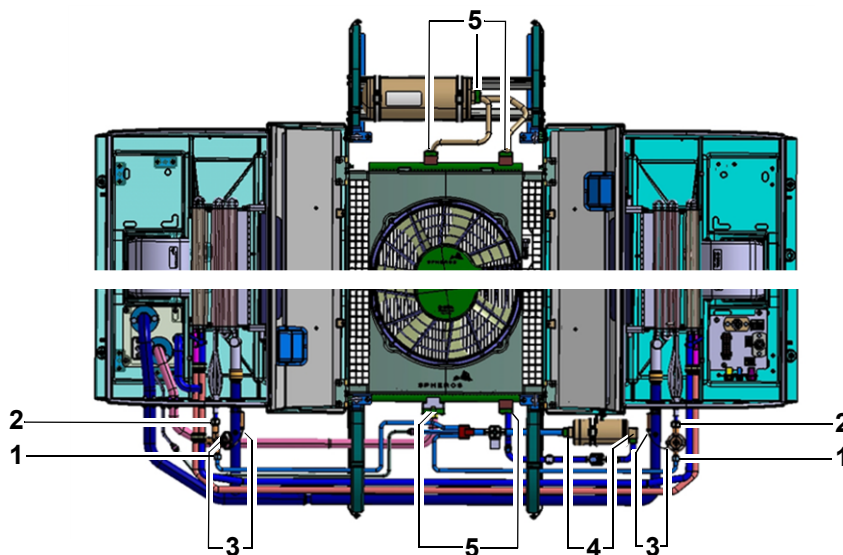

Item	Designation	Torque in NM	O-rings (R134a-resistant)	Valeo Ident. No.
1	D10 with 5/8" union nut UNF	17 ± 10%	7,65 x 1,78	80812A
2	D12 with 3/4" union nut UNF	25 ± 10%	10,82 x 1,78	80640A
3	D6 with 7/16" union nut UNF	10 ± 10%	4,48 x 1,78	1103522A
4	D16 with 7/8" union nut UNF	40 ± 10%	14 x 1,78	80641A
5	Screw M6x25	9 ± 10%	26 x 2,0	69052A

3 Maintenance

Maintenance of the air conditioning system includes the following activities:

- In regular time intervals, according to accumulating dust and vehicle driving performance:
 - Cleaning of evaporator and condenser fins, as well as air filter cleaning or replacement if installed
- Furthermore within the scope of every vehicle maintenance:
 - Functional test of evaporator and condenser fan
 - Functional test of the electro-magnetic coupling
 - Check V-belt tension and condition
 - If refrigerant compressor with inspection glass is installed:
 - Check oil level in the refrigerant compressor
 - Check refrigerant filling in the circuit:
 - After approx. 5 minutes of operation of the air conditioning system, the refrigerant must flow through the inspection glass without bubbles, while the electromagnetic coupling is switched on and the engine speed is increased.
- During the cold season:
 - In order to prevent drying of the refrigerant compressor shaft seal, switch air conditioning on once a month for approx. 15 min at ambient temperature $>5^{\circ}\text{C}$.
- Visually inspect the refrigerant collector as well as all air conditioning system components within the scope of maintenance. In particular look for corrosion and mechanical damage. For safety reasons any materials not in proper conditions must be replaced.

ATTENTION:

Within the scope of the Pressure Vessel Ordinance the carrier is obligated to have the refrigerant collector inspected by an expert on a regular base.

NOTE:

In order to ensure smooth operation of the air conditioning system, the refrigerating machine (chiller) oil and the filter dryer must be replaced 6 months after system start-up. The filter dryer should be replaced on a yearly base prior to cooling period start. These tasks should be performed by authorized certified specialists, who should inspect the air conditioning system for functionality and leak-tightness as well.

1. Soldering of piping and heat exchangers is strictly forbidden.
2. When replacing piping, heat exchangers or components such as filter dryer or expansion valves, the specified screw connection torques must be met. When tightening screw connections, they must be locked. Furthermore, it must be ensured that plenty of refrigerating machine oil is applied to the thread as well as collar of the union nut, when tightening screw connections. When replacing the filter dryer, the thread must be coated with Atmosit to prevent contact corrosion. Valeo identification number: 11113517A
However, it must be ensured that the first two thread turns are NOT coated in order to prevent Atmosit entering the refrigerant circuit (expansion valves may clog).

Warranty claims can only be asserted, when compliance with maintenance and safety information can be demonstrated by the claimant.

4 Maintenance and service plan

General

Similar to all vehicle parts, the air conditioning system is exposed to continuous load. In order to ensure smooth system operation and to prevent parts damage, specified air conditioning maintenance activities must be performed on a regular base by trained experts in air conditioning systems.

Proper system treatment together with the proof, that all specified maintenance activities were performed (completed maintenance and service plan) is prerequisite for acknowledgement of any possible warranty claims regarding damage on parts subjected to maintenance.

Independently from the maintenance intervals in the maintenance and service plan, all system mountings and refrigerant line fittings must be inspected for tight fit within the first four weeks after initial start-up of the air conditioning system and/or vehicle.

Even if the air conditioning system is not operated, individual component wear caused by normal ageing or bus driving operation load can occur. Thus, the inspections in the maintenance and service plan must be performed independently of the system operating time.

Refrigerant loss is possible despite tight line connections. Based on their material structure, the diffusion rate of refrigerant hose lines varies depending on the ambient temperature. However, in case of relatively large refrigerant losses in short intervals, a system leak should be assumed.

In order to prevent drying of the shaft seals of the refrigerant compressor or stopping of moving parts within the refrigerant circuit caused by gumming (oil), the air conditioning system must be switched on at least once a month for approx. 15 min. during times of non-operation. A minimum ambient temperature of $> 5\text{ }^{\circ}\text{C}$ or a heated hall is required.

The pulley of the electro-magnetic coupling is continuously rotating during vehicle engine operation. Thus, bearing wear or possible coupling damage is almost completely independent from the operating time of the air conditioning system. When inspecting the coupling for dry running of the bearings etc. the maintenance instructions must absolutely be followed.

ATTENTION:

- The refrigerant collector is subjected to the Pressure Vessel Ordinance. Inspect the refrigerant collector every 6 months for cracks, corrosion or other damage.
- In case of cracks, mechanical damage or corrosion the refrigerant collector must be replaced.
- The maintenance intervals specified in the maintenance and service plan refer to the operating hours of the vehicle. The only exception is the compressor unit, which refers to the operating hours of the air conditioning system.
- These specified times are empirical values, which may significantly vary depending on system and bus type.
- Maintenance intervals always refer to the event happening first.

NOTE:

The use of contrast medium in the refrigerant circuit is not permitted and leads to loss of warranty.

Maintenance interval			System part	Maintenance activities	Time required in min. (approx.)	Date performed / signature
<input type="checkbox"/>	<input checked="" type="checkbox"/>	<input type="checkbox"/>				
			Drive unit			
		X	– Compressor	Check attachment / add-on parts for cracks, retighten, if necessary, or replace	5
X				Check level in the lower third of the sight glass with compressor „ON“ NOTE: The system must be operated for at least 10 minutes!	5
				Oil charge: Purging, recycling, charging, evacuation NOTE: One-off oil change within the scope of the initial maintenance check of the system, 6 months after initial start-up at the most. Thereafter, we recommend that the oil change be carried out every 3 years (10,000 - 12,000 hours of operation) instead of every year as before.	240
		X		Functional check: Check for working pressures and abnormal noise	10
	X		– Magnetic clutch	Check for proper engagement without slip and abnormal noise	5
	X		– V-belt	Check for proper tension and condition	5
		X	– Tensioning roller	Check for proper functioning (spring tension) and abnormal bearing noise	5
			Refrigeration cycle			
		X	– System	Check fittings and lines for leaks	10
		X	– Refrigerant charge	At 1500 – 1700 rev/min and after 2 minutes operating time, no bubbles must be visible in the sight glass. NOTE: Check system pressure and temperature, prior to the start of the warm weather months at the latest	15
		X	– Thermal expansion valve	Check attachment and isolation of sensor	5
		X	– Filter drier	Replace NOTE: Replace filter drier 6 months after initial start-up	30
	X		– Refrigerant receiver	Check for cracks, corrosion and other damage	5
			Electrical components			
		X	– Electrical wires	Check for oxidation and chafed places	5
		X	– Relays, fuses, dampers, pressure switches, thermostats	Check for proper operation	10
		X	– Control system	Check according to specs	5
		X	– Condenser and evaporator fans	Check for proper operation, bearing noise, direction of rotation and security of attachment	10

Please harmonise with vehicle's maintenance and service chart.

<input type="checkbox"/> monthly or 200 hrs.	<input checked="" type="checkbox"/> every 6 months or 400 hrs.	<input type="checkbox"/> yearly or 800 hrs. (year-round operation: every 6 month or 400 hrs.)
--	--	---

Maintenance interval			System part	Maintenance activities	Time required in min. (approx.)	Date performed / signature
<input type="checkbox"/>	<input type="checkbox"/>	<input type="checkbox"/>				
			Air filters			
X			– Fresh air filter	Check, clean, if necessary, or replace	10
X			– Recirculation air filter	Check, clean, if necessary, or replace	10
			Evaporator/condenser			
		X	– Fins	Check, clean if necessary	19
		X	– Condensation drains	Check for obstructions, clean if necessary	10
			Cover			
		X	– Hoods	Check for tightness. If necessary tighten hood screws with 6 Nm.	2

Please harmonise with vehicle's maintenance and service chart.

monthly or 200 hrs.
 every 6 months or 400 hrs.
 yearly or 800 hrs. (year-round operation: every 6 month or 400 hrs.)

