

PARTS & SERVICE

Spare parts list

REVO Global 400

Overview	fig. 1
System control components	fig. 2
Cover	fig. 3
Condenser, axial fan	fig. 4
Refrigerant receiver	fig. 5
Piping components for refrigerant connections at LH side	fig. 6
Piping components for refrigerant connections at RH side	fig. 7
Components	fig. 8
Piping, components for water connection at RH side	fig. 9
Links/piping, components for water connection at LH side	fig. 10
Flap actuator, air filter	fig. 11
Wiring harnesses	fig. 12
Standard parts, semi-finished parts	page 18

Required data for quick spare part identification:

- A/C unit model: e.g. REVO GLOBAL
- Spheros ID: e.g. 11116166A
- Date of production: e.g. 20141024
- Serial no.: e.g. 14182756

SPHEROS		E1 10R-03 6176
Made in Germany		
Model	REVO GLOBAL	
Spheros ID	11116166A	
Customer ID		
P COOLING / P HEATING	32KW / 38KW	
VOLTAGE	24V	
REFRIGERANT / OIL TYPE	R134a / Ester	
COOLANT	Water / Glycol	
MAX. PRESSURE / A/C-Fr.	25 bar / 2 bar	
Serial No./Date of Prod.	14182756	20141024
		
Year of Initiating	2014	2015 2016

TECHNICAL DATA

REVO Global

400

Cooling capacity

39 kW max

Heating capacity

40 kW *

Air flow (m³ /h)

6,900

Current consumption at full performance

95 amps

Axial blowers

4

Radial blowers

6

Max operating temp. (°C)

54° C

Measurement
L x W x H (mm)

3,000 x 1,900 x 215

Weight (kg)

160

Refrigerant

R134a

* Optional

Revo Global Vicinity Spare Parts List

REVO Global

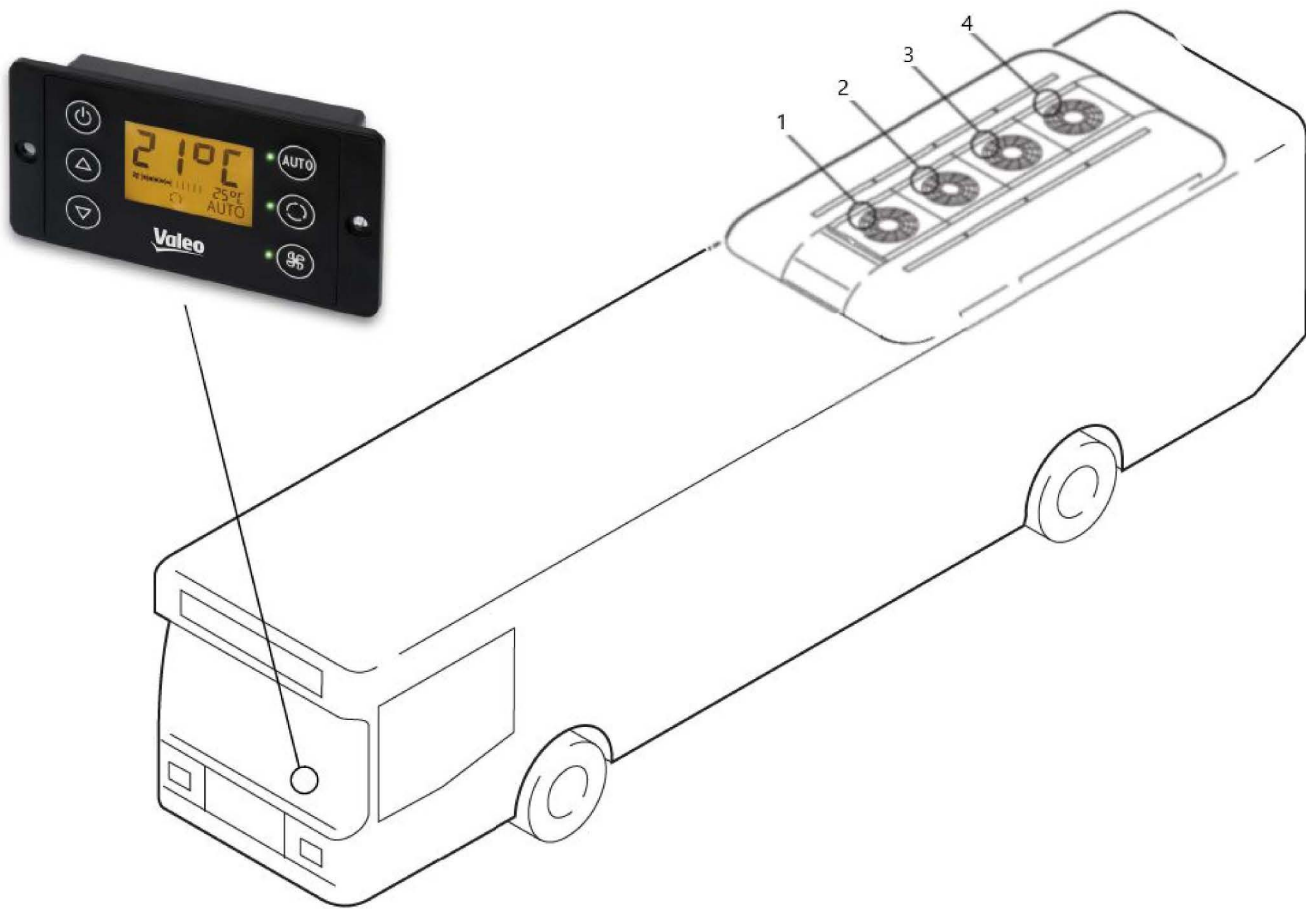

Revo Global Vicinity Spare Parts List



Revo Global Vicinity Spare Parts List.



Revo Global Vicinity Spare Parts List

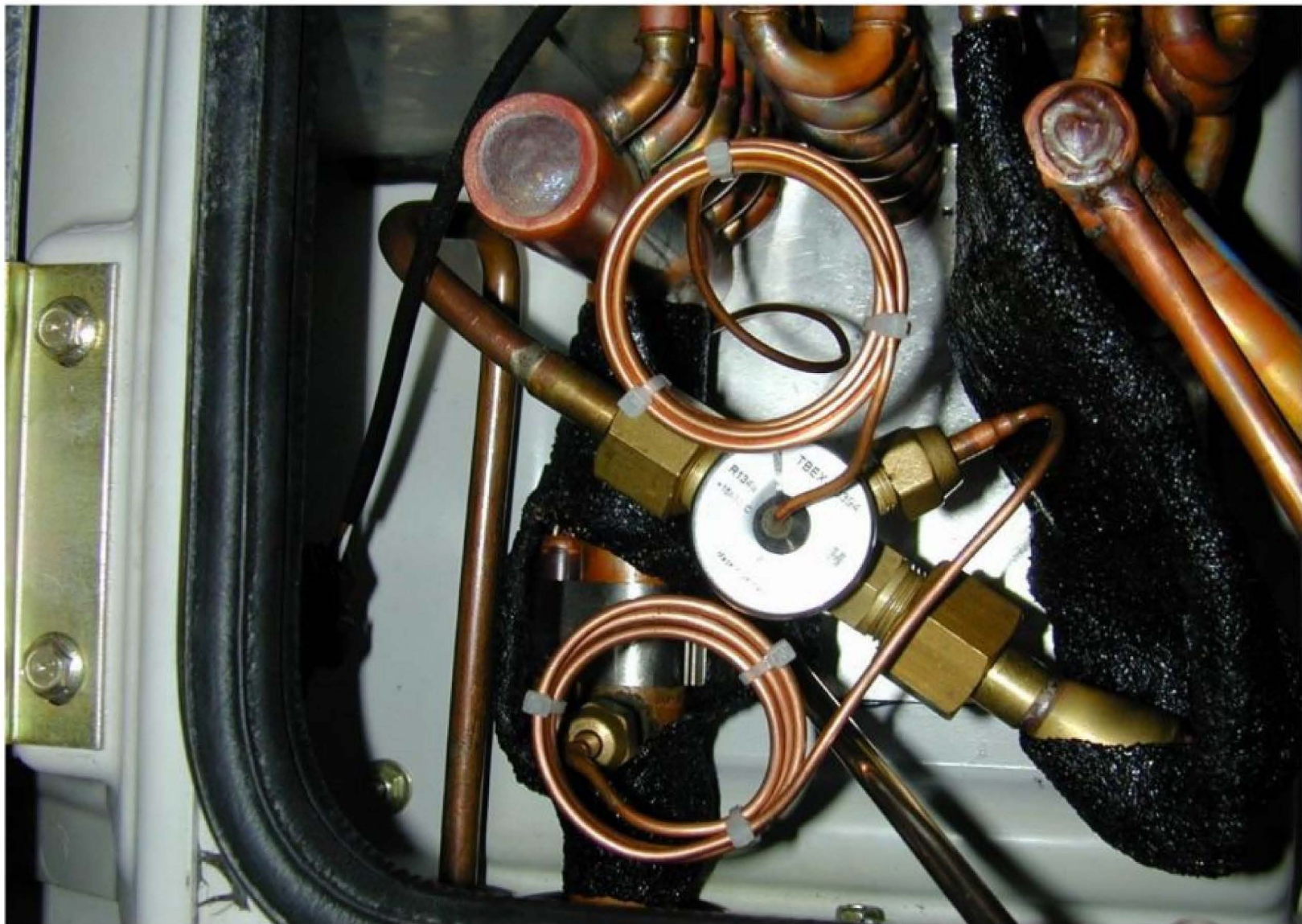

Revo Global Vicinity Spare Parts List



Revo Global Vicinity Spare Parts List



Revo Global Vicinity Spare Parts List

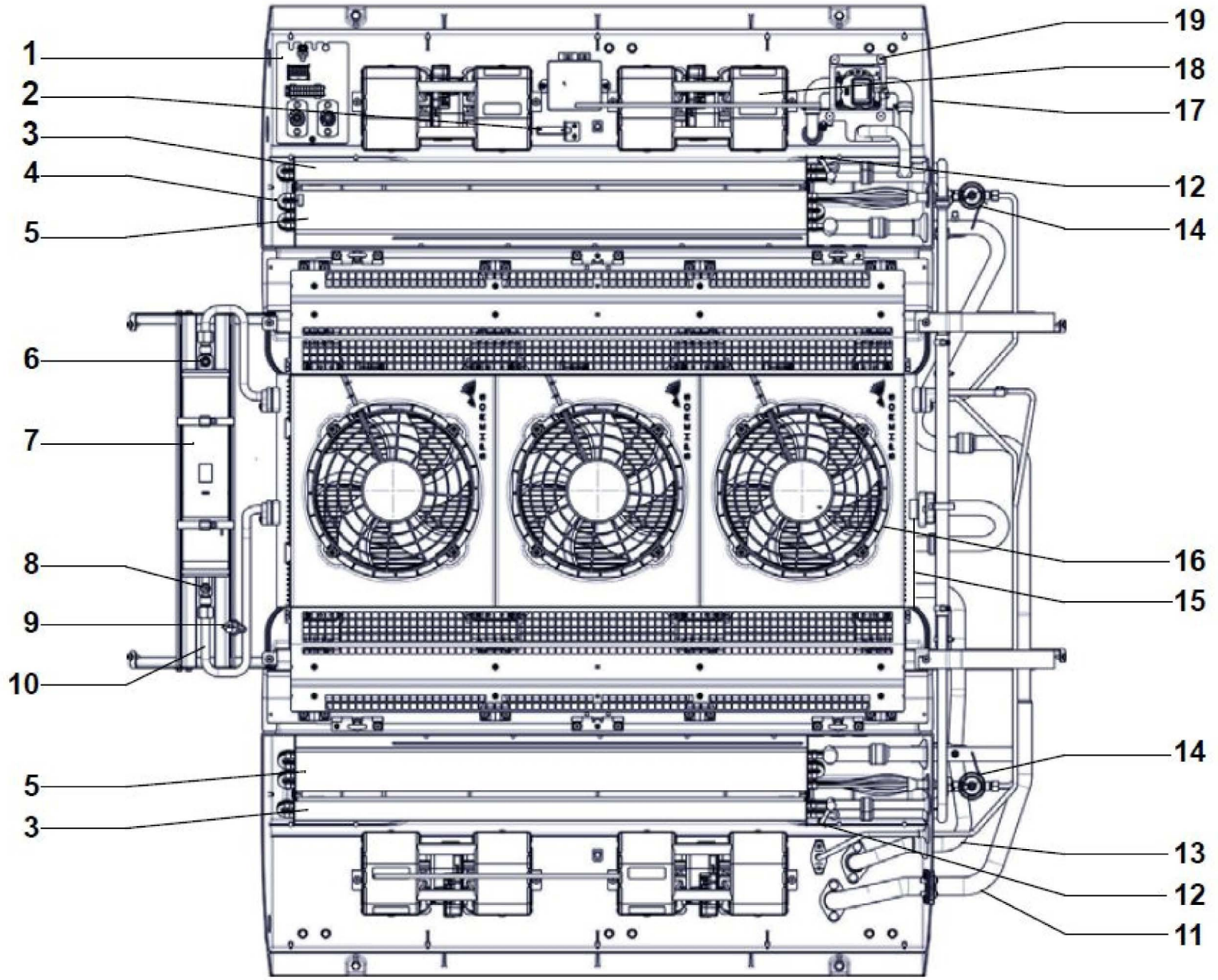

Revo Global Vicinity Spare Parts List

Content:	fig. 0
Overview	fig. 1
System control components	fig. 2
Cover	fig. 3
Condenser, axial fan	fig. 4
refrigerant receiver	fig. 5
Piping, components for refrigerant connection at L	fig. 6
Piping, components for refrigerant connection at F	fig. 7
Componjents	fig. 8
Piping, components for water connection at RH si	fig. 9
Piping, components for water connection at LH si	fig. 10
Flap actuator, air filter	fig. 11
Wiring harnesses	fig. 12
Standard parts, semi-finished parts	page 18

Revo Global Vicinity Spare Parts List

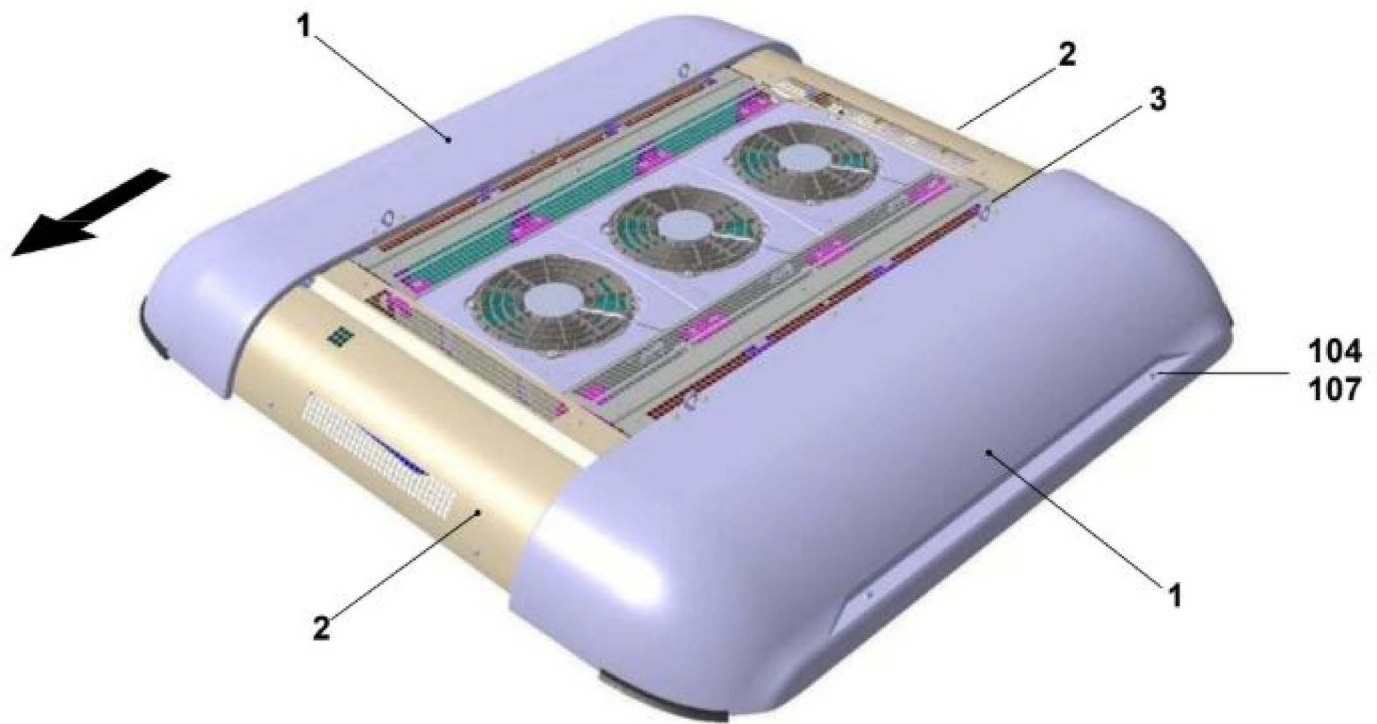

Revo Global 400

Item	Quantity		
1	2	11120271C	COVER LH/RH RG 400, 450, 500
2	2	11119560C	COVER FRONT/REAR RG
3	10	11119562B	HINGE COVER RG
4. no fig	2	11120278A	INSULATION MAT 2560x518x10

Revo Global Vicinity Spare Parts List

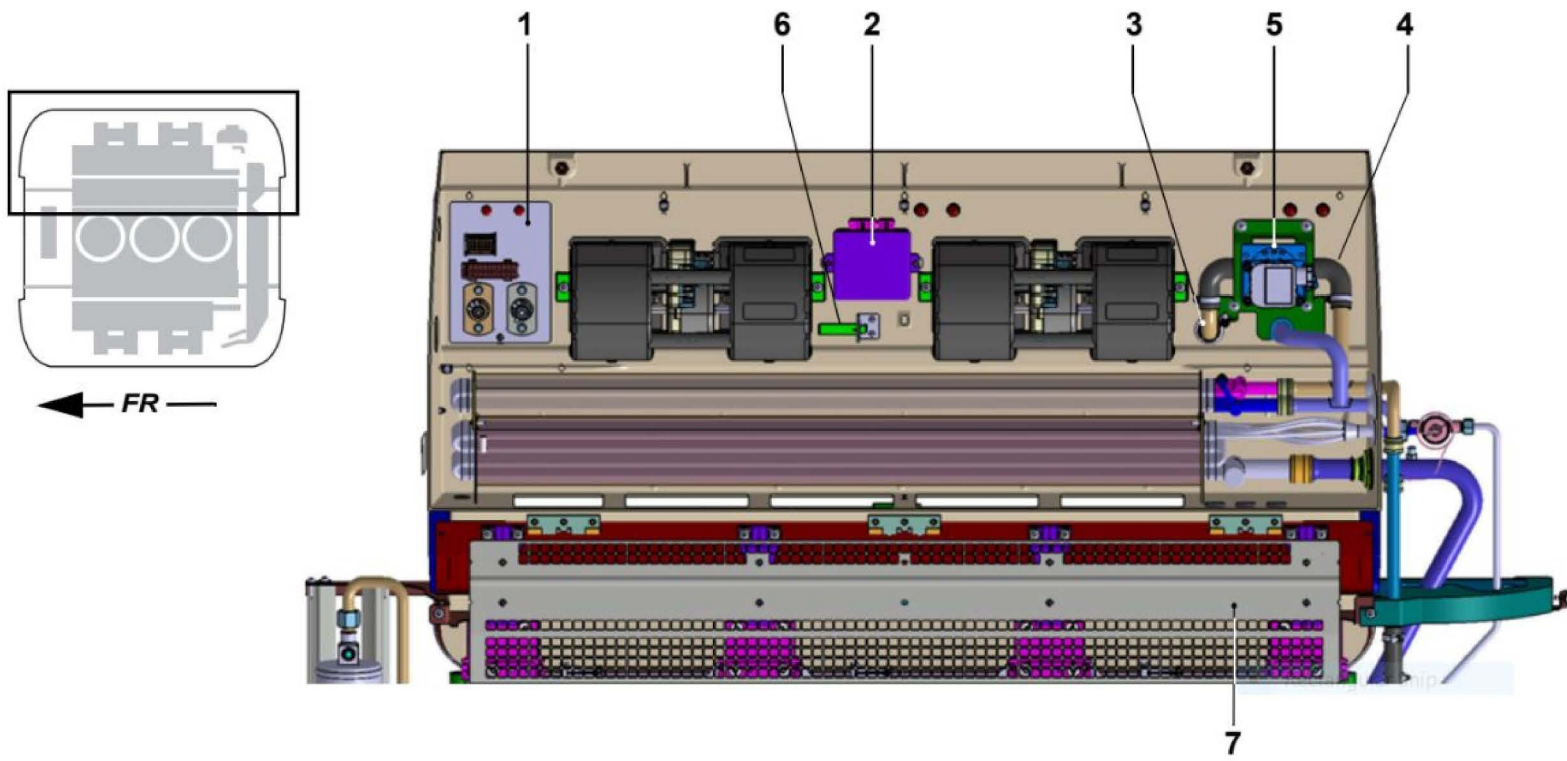

Revo Global 400

Item	Quantity		
1	1	11119730C	POWER DISTRIBUTION CONNECT
3	1	11119018B	PIPE CONNECTION D22 RG
4	2	11119622A	MOLDED HOSE D22x3,5 - 90
5	1	11119561B	WATER VALVE 22/22 AURORA 24V
6	1	11118005A	TEMPERATURE SENSOR EXTERNAL
7	4	11119590C	COVER AIR INTAKE RG

Revo Global Vicinity Spare Parts List

Standard parts from item no. 100 - see page 16

REVO Global - fig. 4

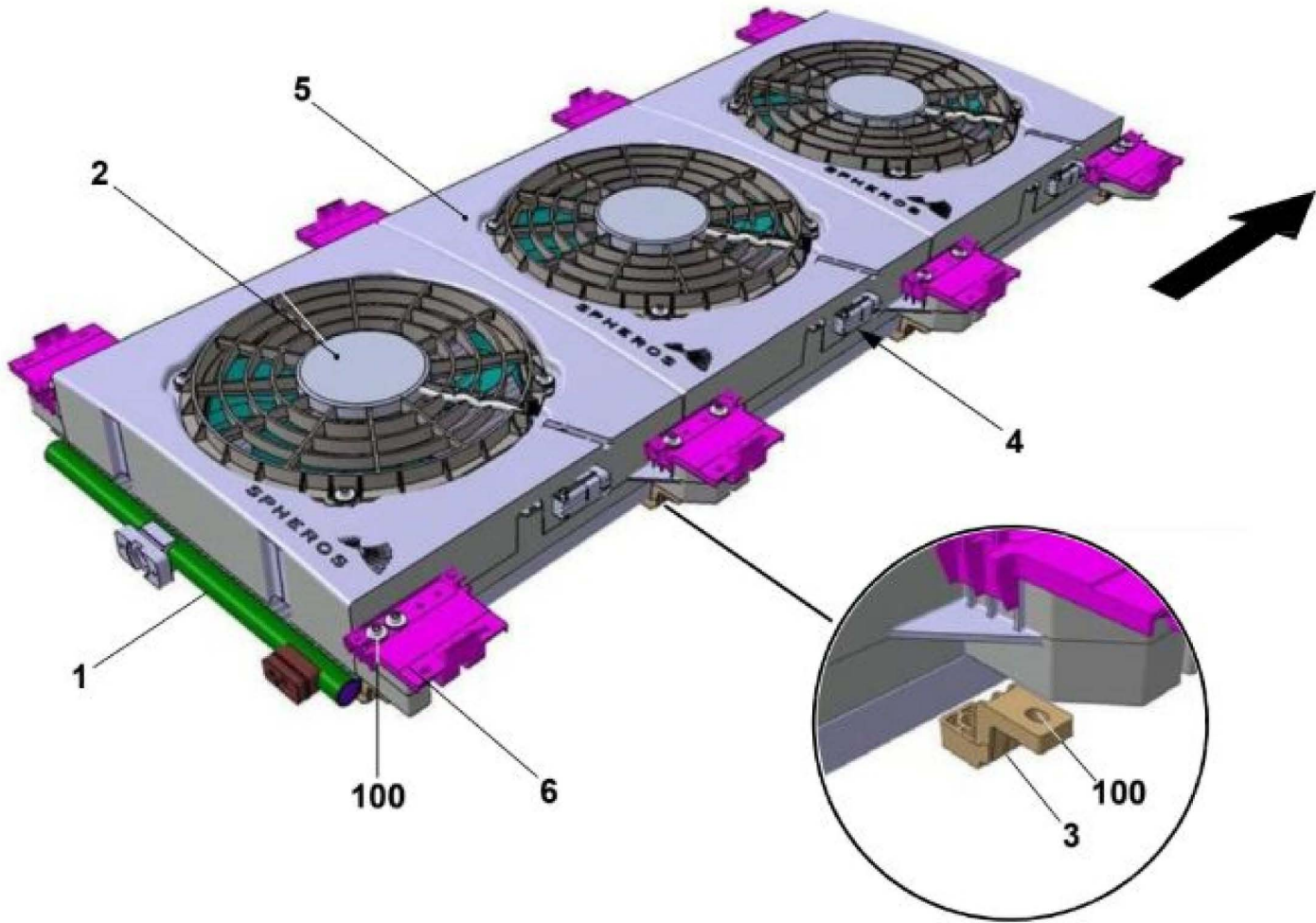

Revo Global 400

Item	Quantity		
1	1	11116916A	CONDENSER MPE 446x2500x20 ZONE 36-7
2	4	11113528C	AXIAL FAN VA82-BBL310-94A
3	16	11114857C	CONDENSER BRACKET
4	1	11120211A	WIRING HARNESS CONDENSER RG 400 450
5	4	11118714D	AXIAL FAN MODULE GLOBAL 600
6	10	11118716B	FIXATION BRACKET I

Revo Global Vicinity Spare Parts List

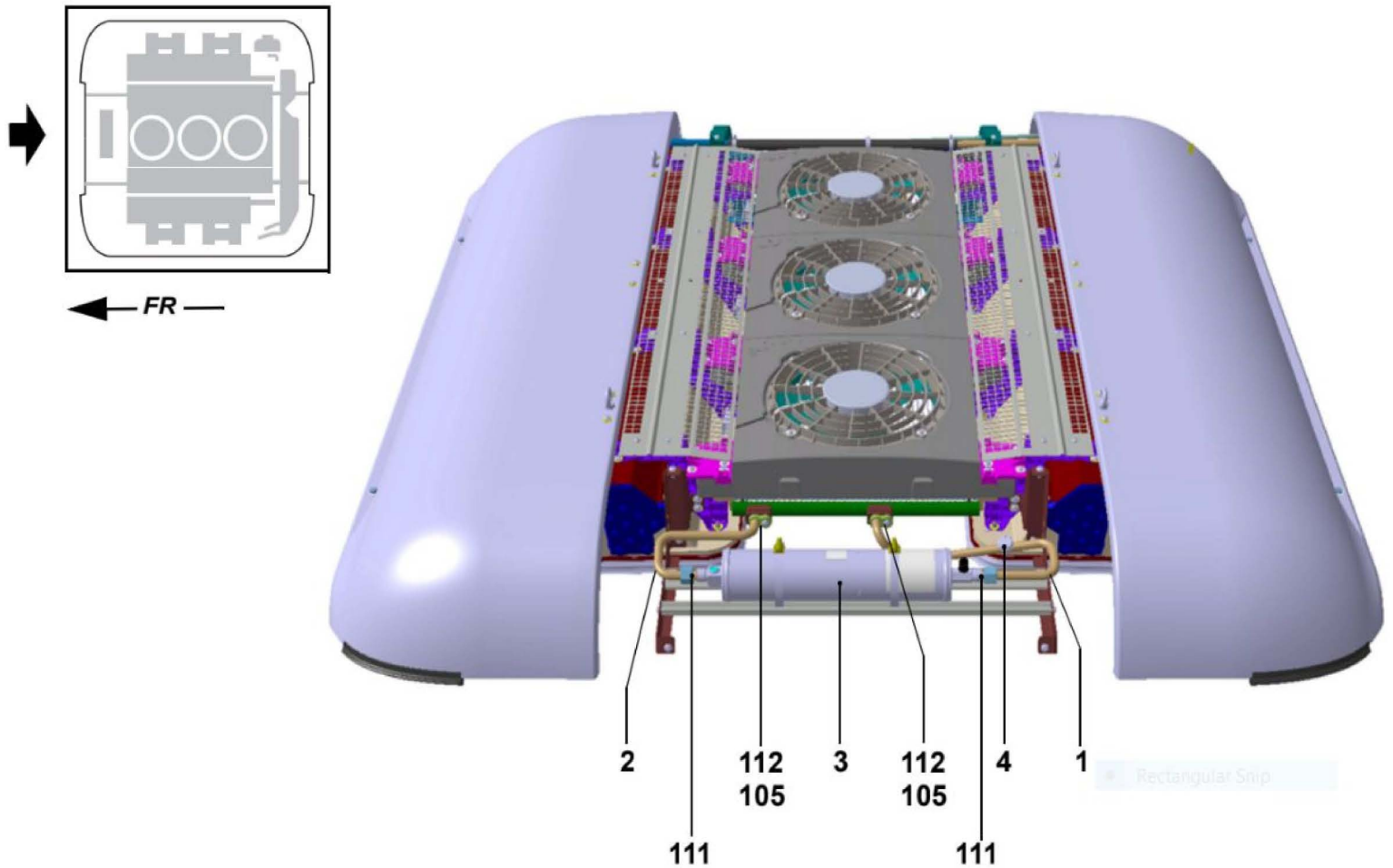

Revo Global 400

Item	Quantity		
1	1	11118997B	CONDENSER-DRYER_ACCUMULATOR PIPE RG
2	1	11118998B	DRYER-ACCUMULATOR-SUBCOOLER PIPE RG
3	1	11119556B	RECEVIER-DRYER 2I AI - RG250
4	1	11114982C	PRESSURE SWITCH

Revo Global Vicinity Spare Parts List

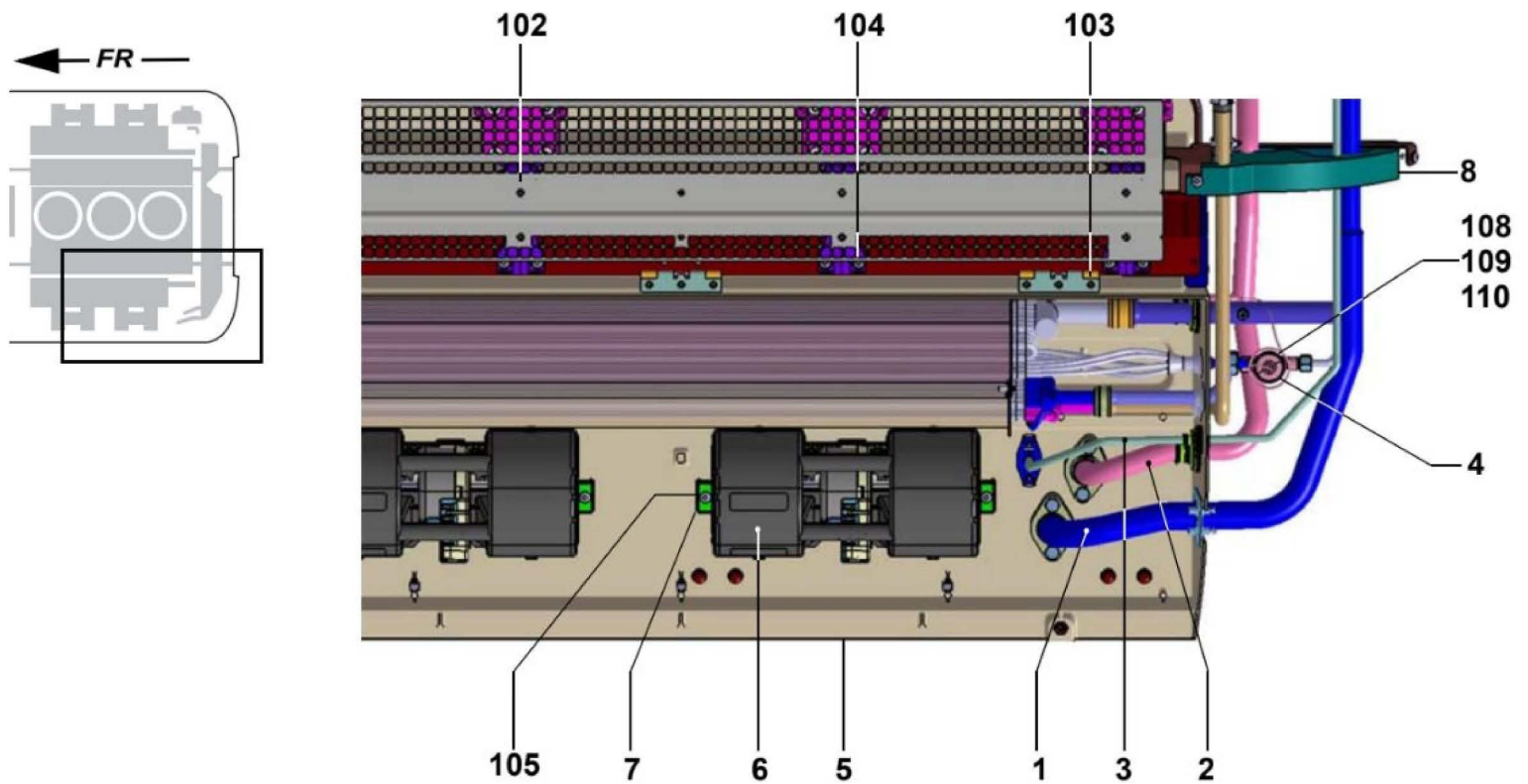

Revo Global 400

Item	Quantity		
1	1	11119014B	SUCTION PIPE CONNECTION LH RG
2	1	11119012C	PRESSURE PIPE CONNECTION LH RG
3	1	11119017B	FRONTBOX PIPE CONNECTION LH RG
4	2	11119611B	EXPANSION VALVE EWB-35M001 CLIP D28
5	2	11119955A	SEALING PROFILE REVO GLOBAL 400_450
6	8	11112674A	XM BASIC RADIAL BLOWER
7	16	1102026C	FAN CLAMP
8	2	11117483A	PIPE CLAMP
9 no fig.	4	11114970A	CONDENSATION WATER LUG

Revo Global Vicinity Spare Parts List

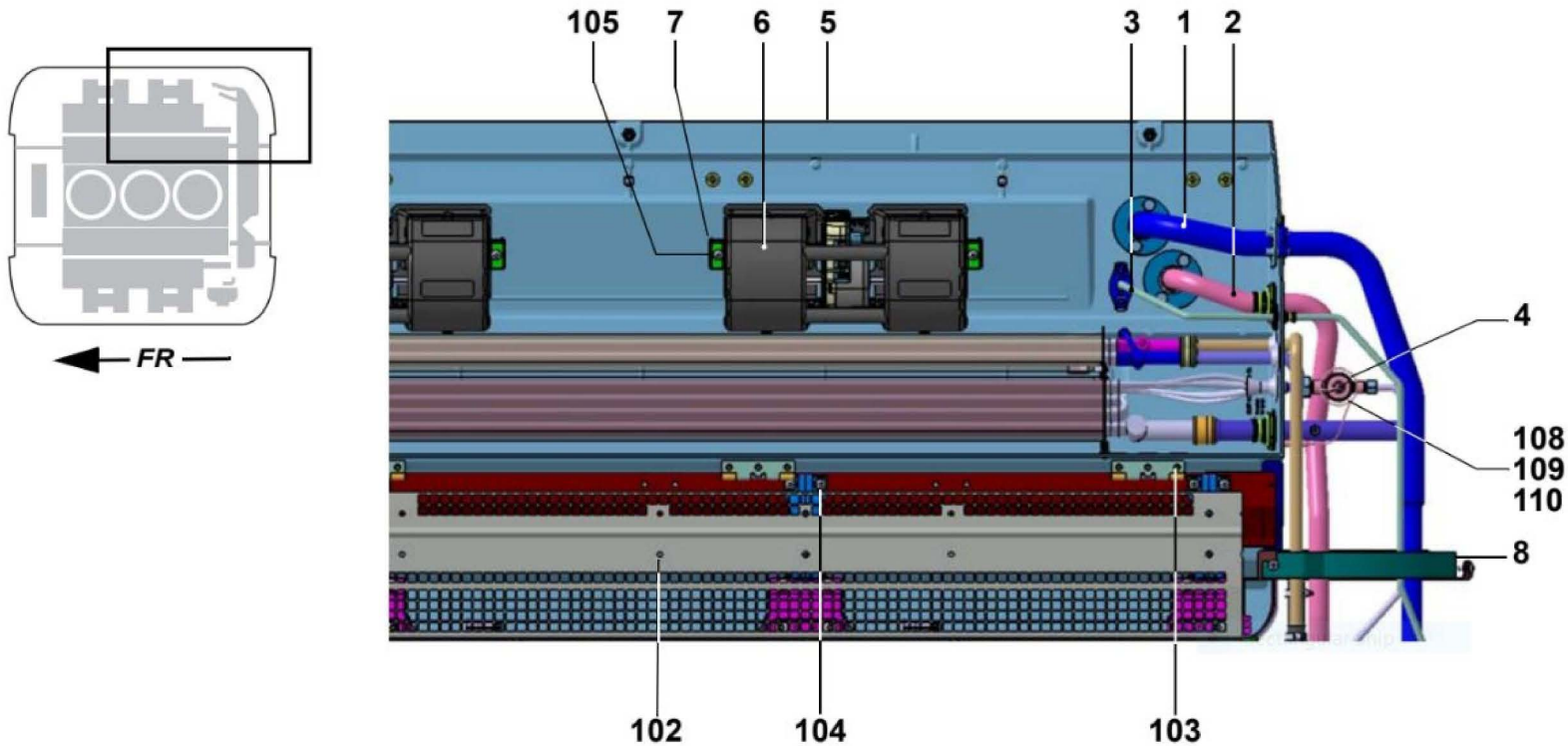

Revo Global 400

Item	Quantity		
1	1	11119820B	SUCTION PIPE CONNECTION RH RG
2	1	11119822B	PRESSURE PIPE CONNECTION RH RG
3	1	11119823B	FRONTBOX PIPE CONNECTION RH RG
4	2	11119611B	EXPANSION VALVE EWB-35M001 CLIP D28
5	2	11119955A	SEALING PROFILE REVO GLOBAL 400_450
6	8	11120703A	XM BASIC RADIAL BLOWER
7	16	1102026C	FAN CLAMP
8	2	11117483A	PIPE CLAMP
9 no fig.	4	11114970A	CONDENSATION WATER LUG

Revo Global Vicinity Spare Parts List

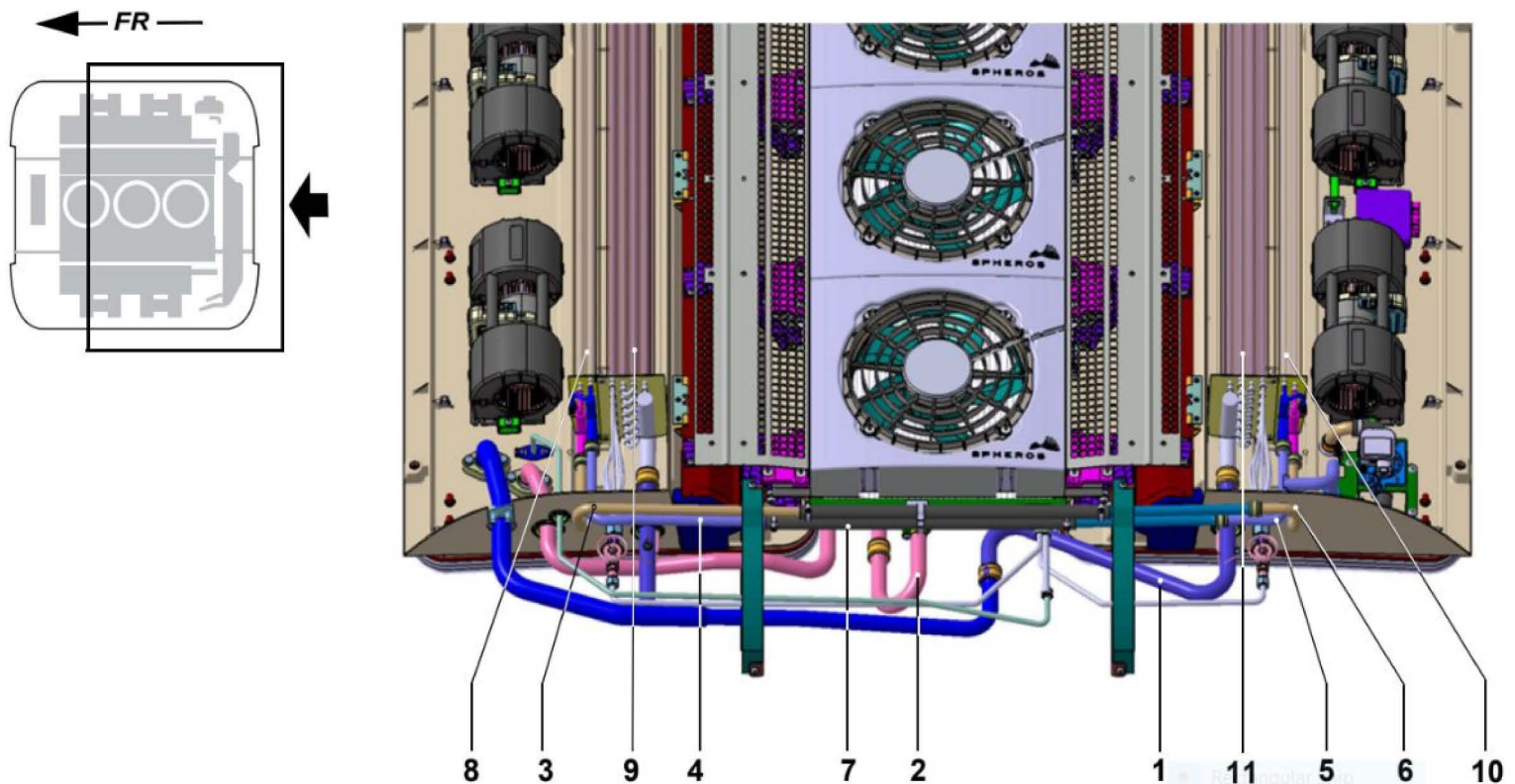

Revo Global 400

Item	Quantity		
1	1	11119013B	SUCTION PIPE CENTRAL RG
2	1	11118998B	DRYER-ACCUMULATOR-SUBCOOLER PIPE RG
3	1	11119032B	WATER PIPE RETURN LH FOR CONN. RH RG
4	1	11119072B	WATERPIPE FLOW LH FOR CONN. RH RG
5	1	11119019B	WATER CONN. RETURN RH RG
6	1	11119020B	WATERCONN. FLOW RH RG
7	2	11119987A	RUBBER HOSE D18x3,5 - 543mm
8	1	11114384C	HEAT EXCHANGER LH
9	1	1114351E	EVAPORATOR LH AL 25x19x2020mm
10	1	11114383C	HEAT EXCHANGER RH
11	1	11114351E	EVAPORATOR LH AL 25x19x2020mm

Revo Global Vicinity Spare Parts List

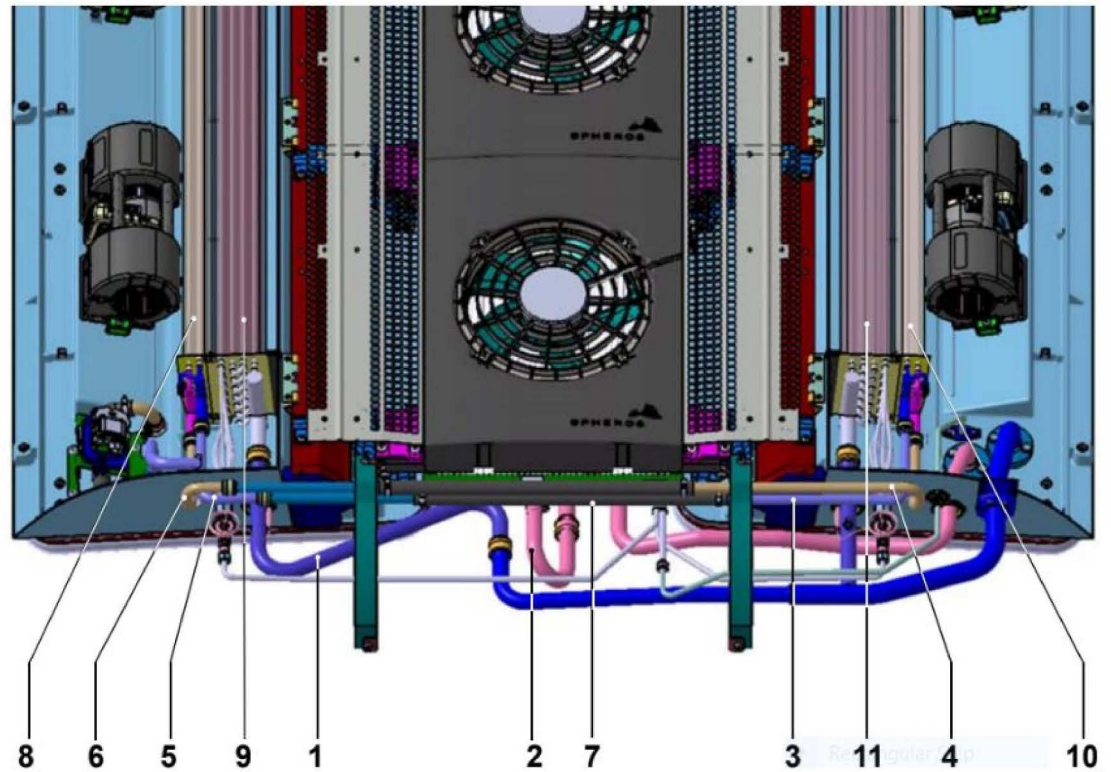
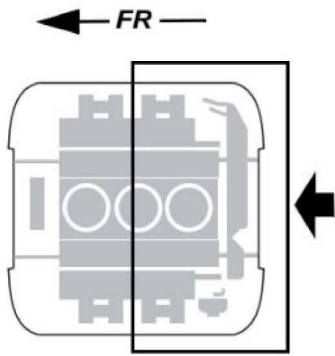

Revo Global 400

Item	Quantity		
1	1	11119013B	SUCTION PIPE CENTRAL RG
2	1	11118998B	DRYER-ACCUMULATOR-SUBCOOLER PIPE RG
3	1	11119072B	WATERPIPE FLOW LH FOR CONN. RH RG
4	1	11119825A	WATERCONN. FLOW LH RG
5	1	11119826A	WATER CONN. RETURN LH RG
6	1	11119831A	WATERPIPE FLOW RH FOR CONN. LH RG
7	2	11119987A	RUBBER HOSE D18x3,5 - 543mm
8	1	11114384C	HEAT EXCHANGER LH
9	1	1114351E	EVAPORATOR LH AL 25x19x2020mm
10	1	11114383C	HEAT EXCHANGER RH
11	1	11114351E	EVAPORATOR LH AL 25x19x2020mm

Revo Global Vicinity Spare Parts List

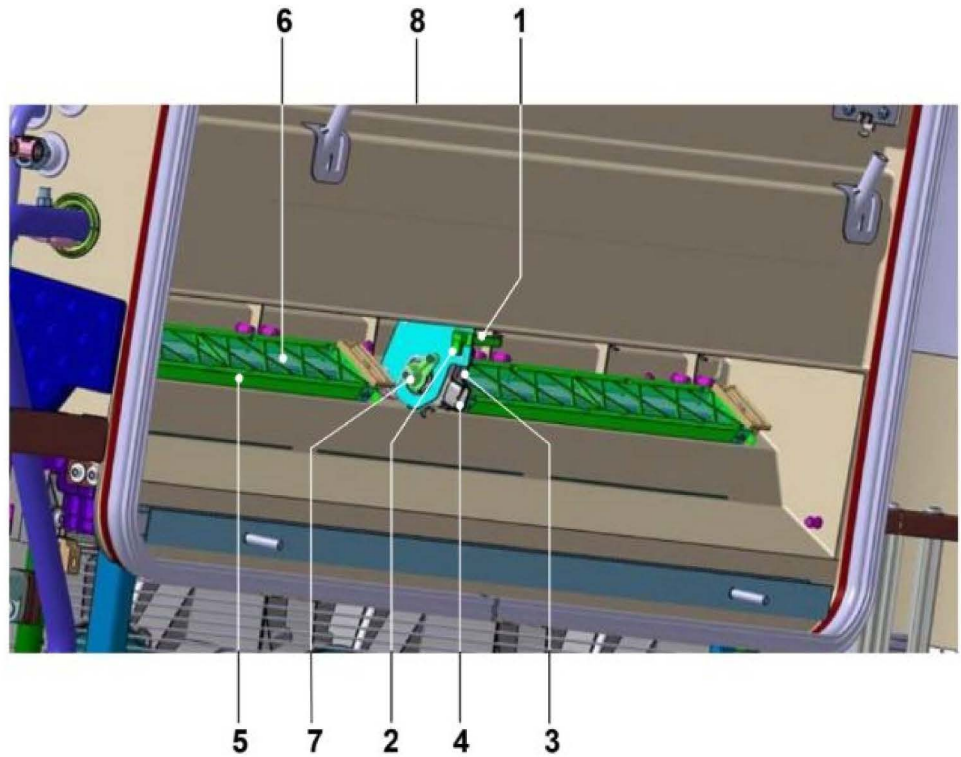
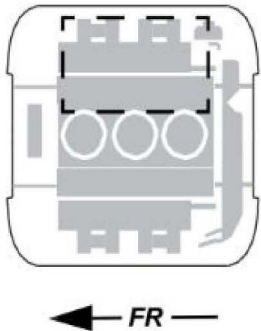

Revo Global 400

Item	Quantity		
1	1	11119232B	TEMP SENSOR EPCOS B58101A812A
2	2	11119232C	WIRING HARNESS INTERNAL TEMP SENSOR RG
3	2	11120134A	FRESH AIR FLAP ACTUATOR
4	2	11121986A	FLAP ACTUATOR WIRING ADAPTER
5	6	11118718B	AIR FILTER CARTRIDGE
6	6	11119607A	FILTER MAT 500x55x20
7	2	11120269A	EXZENTER FLAP UNIT

Revo Global Vicinity Spare Parts List

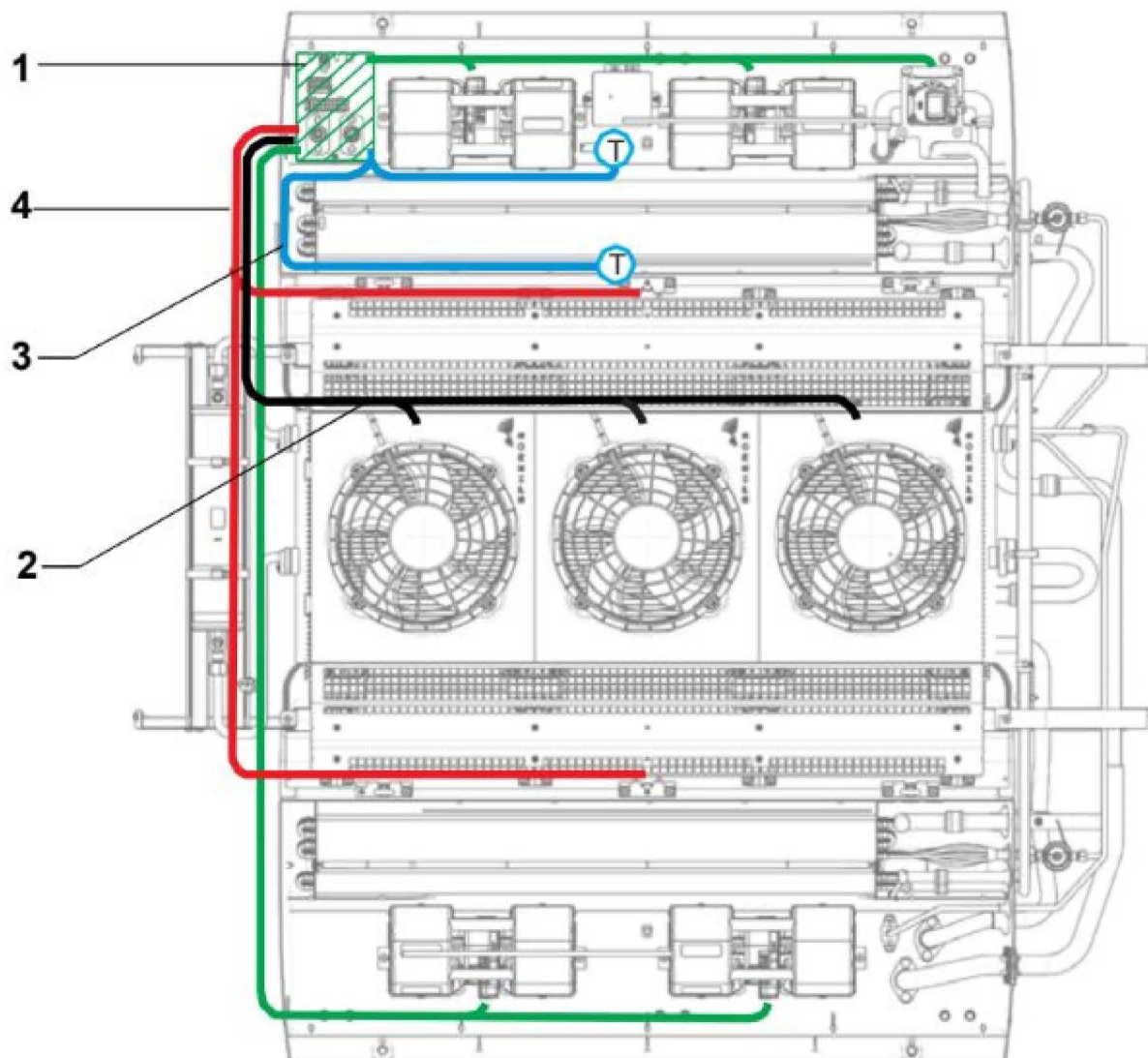

Revo Global 400

Item	Quantity		
1	1	11119730C	POWER DISTRIBUTION CONNECT
2	1	11120211A	WIRING HARNESS CONDENSER RG 400 450
3	2	11119232C	WIRING HARNESS INTERNAL TEMP SENSOR RG
4	2	11119330B	WIRING HARNESS FRESH AIR FLAP

Revo Global Vicinity Spare Parts List

Item	Quantity			
100	1	11115529B	screw, type DS WN5451, 60x22	
101	1	11115527A	screw, type DS WN5451, 40x16	
102	1	11119729A	screw, type DS WN5451, 50x16	
103	1	11118281A	screw Torx head, M6x16	together with item 100
104	1	11120368A	screw Torx head, M6x20	connection evaporator/ heating element
105	1	11115563A	screw Torx head, M6x25	
106	1	11119731A	screw, cover, M8x25	
107	1	11115684A	washer, VA, 8.4x20x1.5	installed together with item 106
108	1	808 2A	O-Ring, 7.65 x 1.78, R134A-resistant	btw expansion valve a. liquid line
109	1	80640A	O-Ring, 10.6 x 1.78, R134A-resistant	expansion valve a. pipe from heat exchanger
110	1	1103522A	O-Ring, 4.48 x 1.78, R134A-resistant	expansion valve a. com- pensation line, 2 times
111	1	80641A	O-Ring, 14 x 1.78, R134A-resistant	receiver
112	1	11117038A	O-Ring, 11 x 2.5,	pipe groups a. receiver
113	1	69052A	O-Ring, 26 x 2,	condenser a. condenser - drier line



Valeo Thermal Commercial Vehicles North America, Inc. - 22150 Challenger Drive Elkhart, IN 46514
Phone 574-264-2190 - Toll free 800-462-6322 - Fax 574-326-3015
www.valeo-thermalbus.com/us - tcv.elkhart-orders.mailbox@valeo.com

Valeo Thermal Commercial Vehicles (TCV), formerly known as ACC Climate Control/Spheros North America.