



PARTS & SERVICE

Klimaanlage
Air conditioning system

Ersatzteil-Liste
Spare parts list

REVO[®]-E

REVO-E-Varianten - Technische Daten im Überblick / REVO-E Variants - Technical data at a glance

REVO-E		Solo single unit 11115678_ (25kW)	Gelenkbus mit zwei Einheiten articulated / two units (master unit 11115678 + slave unit 11117355_2) 1)	REVO-E Hybrid 11124183_ (30kW)	REVO-E compact 11121064_
Kälteleistung/refrigerating capacity (T _{CL1} =35°C, T _{OL1} =40°C) [kW]		25	31	30	24
Luftvolumenstrom/air flow volume [m ³ /h]		6.960	13.920	6960	6960
Heizleistung/heating capacity [kW]		40	80	40	40
Stromaufnahme/ power consumption (24V DC)	maximal (alle 100%)/maximum (all 100%)[A]	78	140	83	78
	nominal (Verflüssiger 80%, Verdampfer 70%) nominal (condenser 80%, evaporator 70%) [A]	49	90	55	49
	geregelt/regulated (die Temperatur im Fahrgastraum ist am Einstellpunkt/passenger compartment temperature at set-point) [A]	10	17	11	10
Stromaufnahme/ power consumption (600V DC)	maximal (Verdichterdrehzahl 50Hz) maximum (compressor speed 50Hz) [A]	22	22	22	22
	geregelt/regulated (die Temperatur im Fahrgastraum ist am Einstellpunkt 25°C - Aussentemperatur 35°C/passenger compartment tempera- ture at set-point 25°C - ambient tempera- ture 35°C) [A]	9	11	9	9
Gewicht/weight [kg]		258	258 + 118	258	248
Abmessungen LxBxH/dimensions LxWxH [mm]		2.800 x 2.091 x 406	master unit: 2.800 x 2.091 x 406 slave unit: 2.600 x 2.077 x 210	2.800 x 2.091 x 406	2.800 x 2.091 x 406

1) „Articulated“ für Gelenkbusse (mit je einer Einheit auf Vorderwagen + einer Einheit auf Hinterwagen) / for articulated buses (with a unit on the forward vehicle + a unit on the rear trailer)

2) Für Gelenkzugausführung: **Die Slave-Anlage ist in der ETL REVO Volvo enthalten.** /
For articulated buses: **The slave unit is included in the REVO Volvo parts list.**

Inhalt/Content:



REVO-E 25 / 30 kW Überblick Aufbau / Overview design	Bild/fig. 1
REVO-E compact Überblick Aufbau / Overview design	Bild/fig. 2
Haube / Cover	Bild/fig. 3
Verflüssiger, Axialgebläse / Condenser, axial fan	Bild/fig. 4
Kältemittelsammler / Refrigerant receiver	Bild/fig. 5
Verrohrung / Piping	Bild/fig. 6
Verrohrung, Verdichter, Elektrik / Piping, compressor, electrics	Bild/fig. 7
Heizteil, Verdampfer / Heating element, evaporator	Bild/fig. 8
Elektrik / Electrics	Bild/fig. 9
Zubehör Kit / Accessory kit	Bild/fig. 10
Normteile, Halbzeuge / Standard parts, semi-finished parts	Seite/page 17

Notwendige Angaben zur schnellen Ersatzteilermittlung: / Required data for quick spare part identification:

- Klimaanlage Typ: z.B. REVO-E Hybrid /
- A/C unit model: e.g. REVO-E Hybrid
- Valeo-Identnummer: z.B. 11115678A
- Valeo ID: e.g. 11115678A
- Produktionsdatum: z.B. 20210514/
- Date of production: e.g. 20210514
- Seriennr.: z.B. 13092766/
- Serial no.: e.g. 13092766

Hinweis: Die Position des Typschildes ist aus Bild 1 auf Seite 3 ersichtlich.

Note: For model plate position, refer to fig. 1 on page 3

Valeo		E1 10R - 05 6913	
MADE IN Germany			
Modell	RevoE Hybrid 250003		
Materialnr. Kundenartikelnr.	11115678A		
HEIZUNG / P HEATING / HEATPUMP	25 / 38 / - KW	600 V	
VOLTAGE	R134a / Ester		
REFRIGERANT / OIL TYPE	Wasser - Glykol		
OPER. PRESSURE / A/C-HT	25 bar / 2bar		
Serialnr./Herstelltdat	13092766	20210514	
 			
Inbetriebnahmejahr	2021	2022	2023

REVO-E 25 / 30kW * Überblick Aufbau/Overview design - Bild/fig. 1

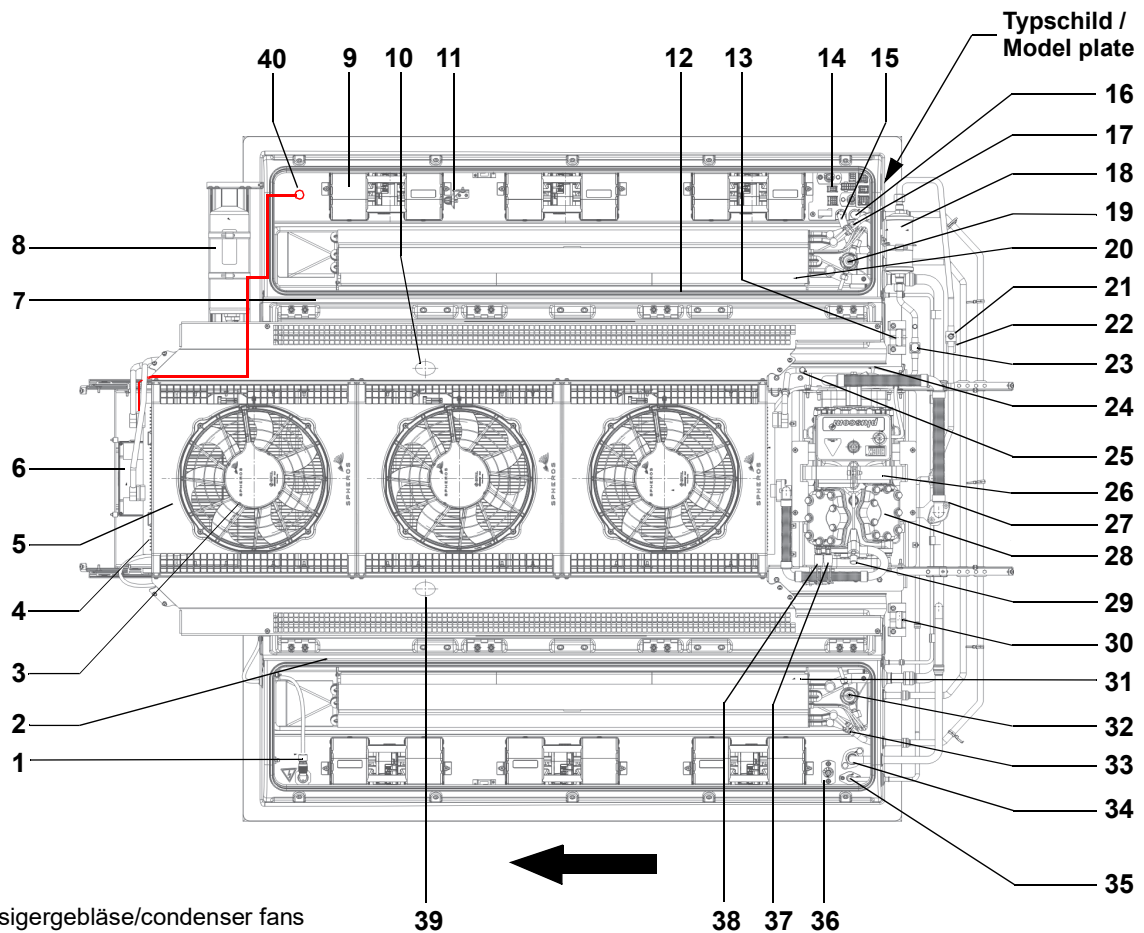

* 4 Verflüssigergebläse/condenser fans

Legende / legend:

- | | | |
|---|---|--|
| 1 Schnittstelle Elektrik 600V | 31 Luftfilter | 14 Elektrical interface 24V |
| 2 Klappenstellmotor (verdeckt) | 32 Expansionsventil | 15 Water feed flow NW20 |
| 3 EC Verflüssigergebläse (3 bzw. 4 Stück) | 33 Entlüftung Heizteil NW6 | 16 Water return NW20 |
| 4 Verflüssiger | 34 Kältemittel-Anschluss, Saugseite, Slave-Anlage | 17 Bleeding port, heating element NW6 |
| 5 Gebläsemodul | 35 Kältemittel-Anschluss, Druckseite, Slave-Anlage | 18 Dryer |
| 6 Frequenzumformer | 36 Erdung (GND), Hochvoltkomponenten | 19 Expansion valve |
| 7 Klappenstellmotor (verdeckt) | 37 Niederdruckschalter | 20 Air filter |
| 8 Kältemittelsammler | 38 Hochdruckschalter | 21 Sight glass |
| 9 Doppelradialgebläse | 39 Sicherungshebepunkt Anlage vorn links | 22 Solenoid valve |
| 10 Sicherungshebepunkt Anlage vorn rechts | 40 Anschluss Diagnose (von unten über Dachkanal) | 23 Shut-off valve |
| 11 Temperaturfühler (Ausblastemperatur) | | 24 Refrigerant charging valve, suction side |
| 12 Temperatursensor Fahrgastraum (verdeckt) | | 25 Safety valve, 30bar |
| 13 Sicherungshebepunkt Anlage hinten rechts | | 26 Bracket, refrigerant compressor |
| 14 Schnittstelle Elektrik 24V | 1 Electrical interface 600V | 27 Suction pressure sensor (hidden) |
| 15 Wasservorlauf NW20 | 2 Flap actuator (hidden) | 28 Refrigerant compressor |
| 16 Wasserrücklauf NW20 | 3 Condenser | 29 Refrigerant charging valve, pressure side |
| 17 Entlüftung Heizteil NW6 | 4 Condenser | 30 Left-hand rear safety lift point of the unit |
| 18 Trockner | 5 Fan module | 31 Air filter |
| 19 Expansionsventil | 6 Frequency converter | 32 Expansion valve |
| 20 Luftfilter | 7 Flap actuator (hidden) | 33 Bleeding port, heating element NW6 |
| 21 Schauglas | 8 Refrigerant collector | 34 Refrigerant connection, suction side, slave unit |
| 22 Magnetventil | 9 Double radial fan | 35 Refrigerant connection, pressure side, slave unit |
| 23 Absperrventil | 10 Right-hand forward safety lift point of the unit | 36 Grounding (GND), high voltage components |
| 24 Kältemittel-Füllventil, Saugseite | 11 Blow-out temperature sensor | 37 Low pressure switch |
| 25 Sicherheitsventil 30bar | 12 Temperature sensor, passenger compartment (hidden) | 38 High pressure switch |
| 26 Halterung, Kältemittel-Verdichter | 13 Right-hand rear safety lift point of the unit | 39 Left-hand forward safety lift point of the unit |
| 27 Saugdrucksensor (verdeckt) | | 40 Terminal for Diagnosis (from below via roof duct) |
| 28 Kältemittel-Verdichter | | |
| 29 Kältemittel-Füllventil, Druckseite | | |
| 30 Sicherungshebepunkt Anlage hinten links | | |

REVO-E compact Überblick Aufbau/Overview design - Bild/fig. 2

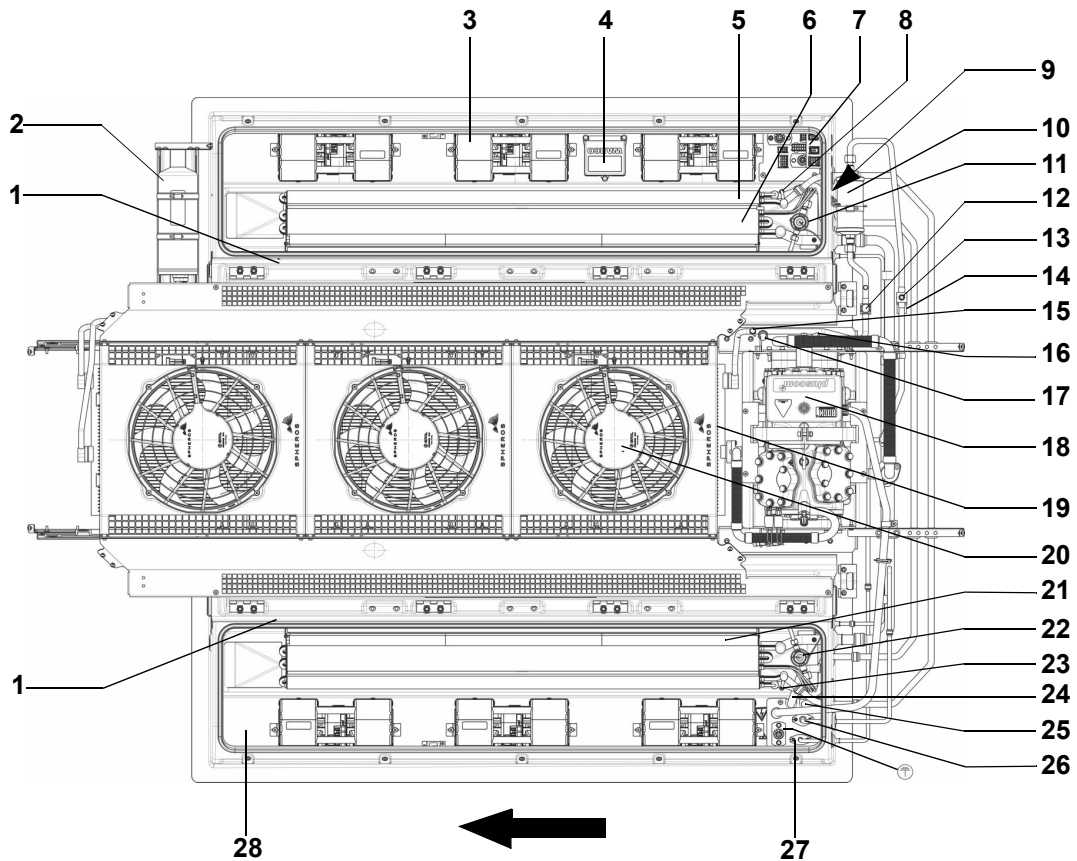

Legende / legend:

- | | | |
|---|--------------------------------------|--|
| 1 Klappenstellmotor (verdeckt) | 20 EC Verflüssigergebläse | 10 Filter drier |
| 2 Kältemittelsammler | 21 Luftfilter | 11 Expansion valve |
| 3 Doppelradialgebläse | 22 Expansionsventil | 12 Shut-off valve |
| 4 Steuereinheit | 23 Entlüftung Heizteil NW6 | 13 Sight glass |
| 5 Luftfilter | 24 Wasservorlauf NW20 | 14 Solenoid valve |
| 6 Eissensor (verdeckt) | 25 Wasserrücklauf NW20 | 15 Safety valve, 30bar |
| 7 Schnittstelle Elektrik 24V | 26 Frontbox Rücklaufanschluss | 16 Refrigerant charging valve |
| 8 Entlüftung Heizteil NW6 | 27 Frontbox Vorlaufanschluss | 17 Pressure Switch (axial fan control) |
| 9 Position Typschild | 28 Schnittstelle Elektrik 600V | 18 Refrigerant compressor |
| 10 Filter-Trockner | | 19 Condenser |
| 11 Expansionsventil | 1 Flap actuator (hidden) | 20 EC condenser fan |
| 12 Absperrventil | 2 Refrigerant collector | 21 Air filter |
| 13 Schauglas | 3 Double radial blower | 22 Expansion valve |
| 14 Magnetventil | 4 Control unit | 23 Bleeding port, heating element NW6 |
| 15 Sicherheitsventil 30bar | 5 Air filter | 24 Water feed flow NW20 |
| 16 Kältemittel-Füllventil | 6 Ice sensor (hidden) | 25 Water return NW20 |
| 17 Druckschalter (Steuerung Axialgebläse) | 7 Electrical interface 24V | 26 Frontbox return connection |
| 18 Kältemittel-Verdichter | 8 Bleeding port, heating element NW6 | 27 Frontbox flow connection |
| 19 Verflüssiger | 9 Position type label | 28 Electrical interface 600V |

Normteile ab Pos. 100 siehe Seite 17
Standard parts from item no. 100 - see page 17

Bild/fig. 3

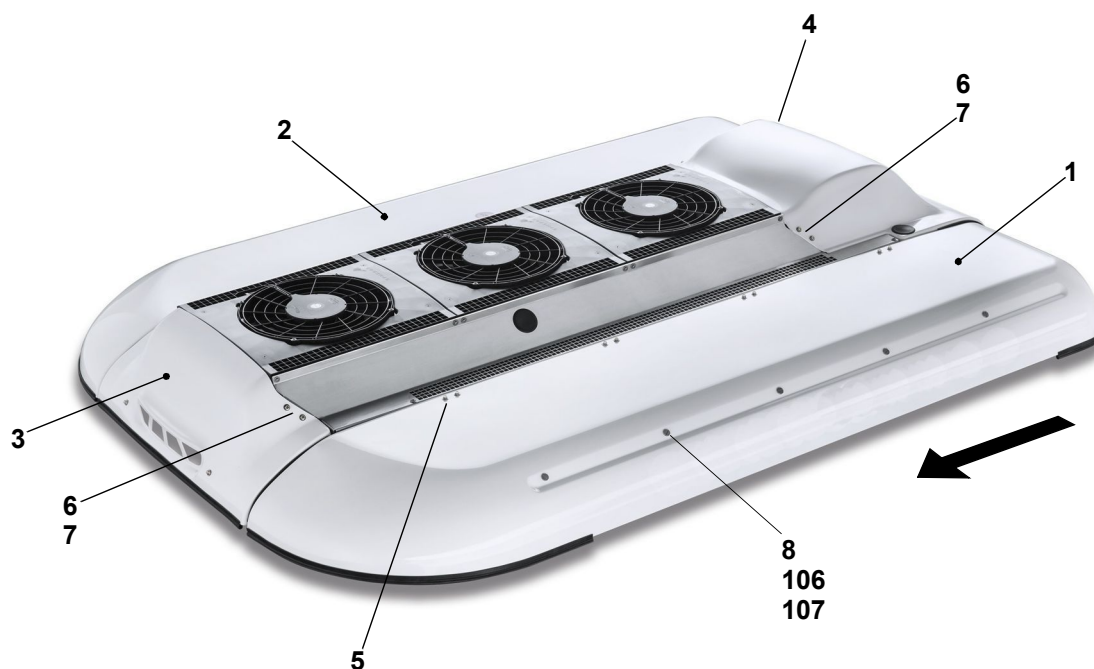

Pos./Item	Stück/Quantity			Bestell-Nr./Part. no.	Benennung	Description	Bemerkung/Remarks
	25kW	30kW	comp.				

Haube / Cover

1	1	1	1	11117407A	Haube, links, ZSB	cover assy, LH	
2	1	1	1	11117408A	Haube, rechts, ZSB	cover assy, RH	
3	1	1	1	11116776A	Haube, vorn	cover, front	
4	1	1	1	11116811B	Haube, Verdichter	cover compressor	
5	8	-	-	1103668A	Haubenscharnier	hinge, cover	
5	-	8	8	1103580B	Haubenscharnier	hinge, cover	
6	6	6	6	11118281A	Sicherungsschrauben M6x16	locking screw	T30
7	6	6	6	15355B	Unterlegscheibe M6x18	washer	
8	1	1	1	11111228A	Haubenschraubenkit	cover screws kit	inkl. Pos. 106 (10x), 107 (10x), Gewindeinsatz (10x), Kleber (1x), Anleitung zum Kleben/ incl. item 106 (10ea), 107 (10ea), thread insert (10ea), glue (1ea), gluing instructions
9 no fig.	2	2	2	1102433A	Haubenstange	cover support rod	
10 no fig.	4	4	-	11114970A	Kondenswasserstutzen	condensed water drain	
10 no fig.	-	-	4	92610A	Kondenswasserstutzen	condensed water drain	

Normteile ab Pos. 100 siehe Seite 17
Standard parts from item no. 100 - see page 17

Bild/fig. 4

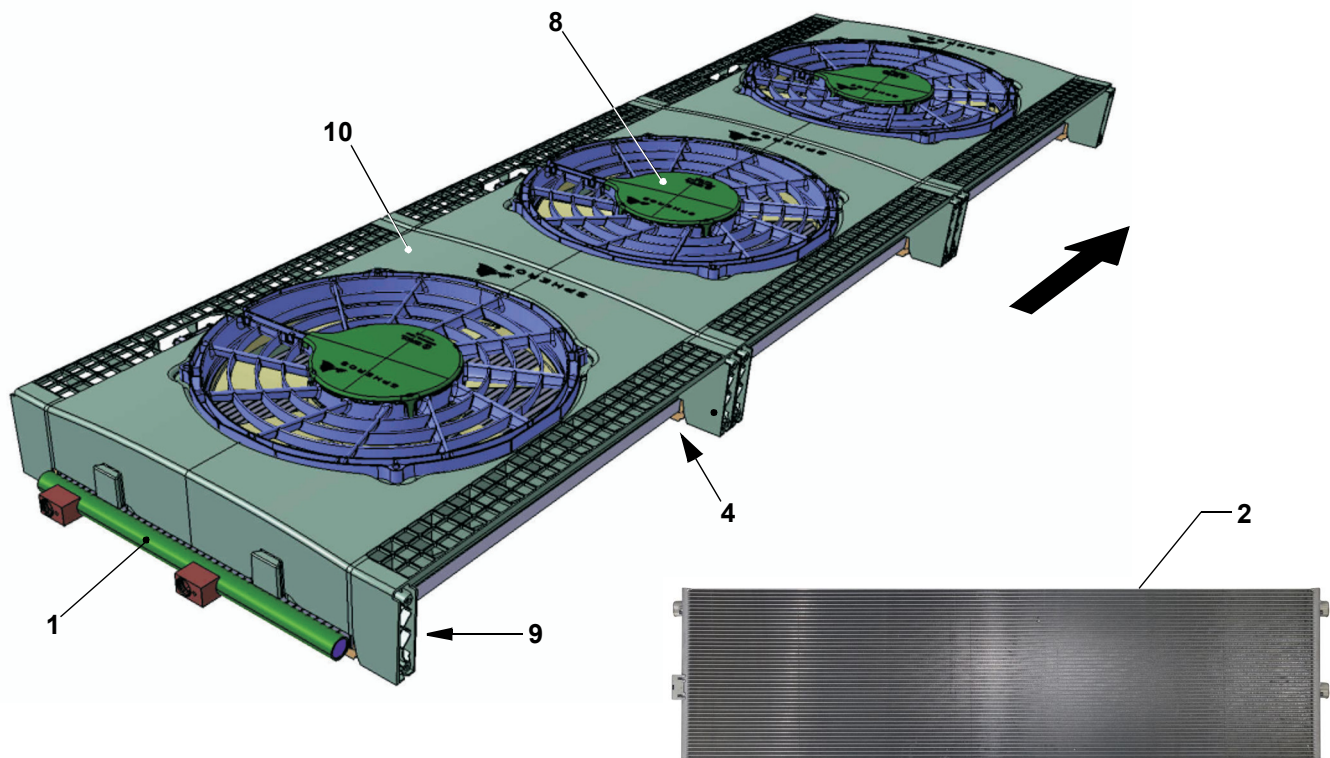

Pos./Item	Stück/Quantity			Bestell-Nr./Part. no.	Benennung	Description	Bemerkung/Remarks
	25kW	30kW	comp.				

Verflüssiger, Axialgebläse / condenser, axial fan

1	1	-	-	11123465A	Verflüssiger-Modul	condenser module	
2	-	1	1	11122551A	Verflüssiger	condenser	
3 no fig.	-	8	6	11123184A	Halter Verflüssiger LH	bracket condenser LH	zu 2 / for 2
4	-	8	6	11123206A	Halter Verflüssiger RH	bracket condenser RH	zu 2 / for 2
5 no fig.	-	16	12	11115529B	DELTA PT Schraube	screw DELTA PT	zu 2 / for 2
6 no fig.	-	8	6	11115626A	Kabelbinder	cable tie	zu 2 / for 2, 4.8x150 PA66
7 no fig.	-	4	3	30976A	Kabelbinder	cable tie	zu 2 / for 2, 4.8x150 PA66
8	3	-	-	11114716C	Axialgebläse, 405mm	axial fan	
8		4	3	11122719C	Axialgebläse, 405mm	axial fan	
9 no fig.	1	1	-	11117348F	Kabelbaum, Verflüssiger	wiring harness, condenser	
9 no fig.	-	-	1	11121431B	Kabelbaum, Verflüssiger	wiring harness, condenser	
10	-	4	-	11115679A	Axiallüftermodul	axial fan module	
10	-	-	3	11114821A	Axiallüftermodul	axial fan module	

Normteile ab Pos. 100 siehe Seite 17
Standard parts from item no. 100 - see page 17

Bild/fig. 5

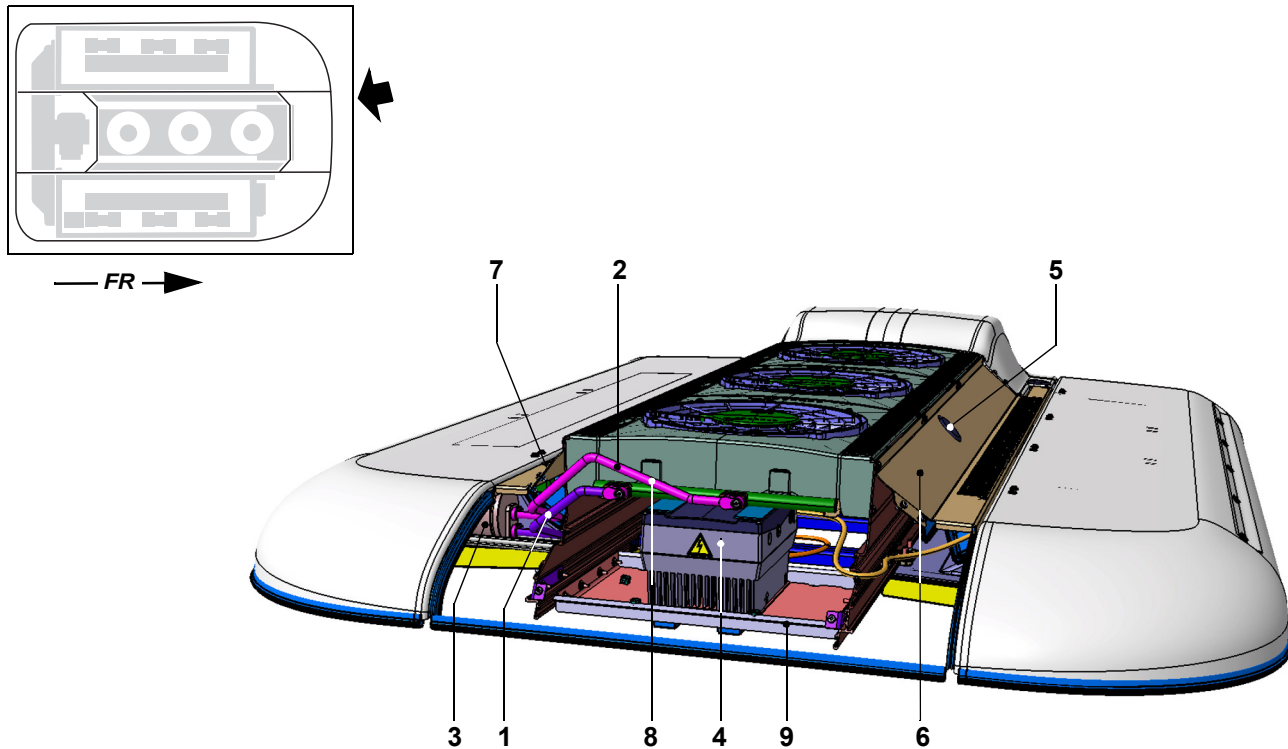

Pos./Item	Stück/Quantity			Bestell-Nr./Part. no.	Benennung	Description	Bemerkung/Remarks
	25kW	30kW	comp.				

Kältemittelsammler / Refrigerant receiver

1	1	1	1	11116616B	Leitung, Sammler-Unterkühler	line, receiver-super cooler	
2	1	1	1	11116617B	Leitung, Verflüssiger-Sammler	line, condenser-receiver	
3	1	1	1	11116914B	Kältemittelsammler 3l	refrigerant receiver	
4	1	1	-	11121755B	Frequenzumrichter 9.2kW/3AC 400V Kit	frequency inverter kit	inkl. Parametersatz incl. parameter set
5	5	5	5	68178A	Verschlusskappe	cap plug	
6	1	1	1	11116673D	Laubgitter, links	protective grille, LH	
7	1	1	1	11116674D	Laubgitter, rechts	protective grille, RH	
8	1	1	-	11118837B	Sensor mit Kabelbaum	temperature sensor with wiring harness	
9	1	1	-	11119063B	Halter, Frequenzumformer	support, frequency converter	

Normteile ab Pos. 100 siehe Seite 17
Standard parts from item no. 100 - see page 17

Bild/fig. 6

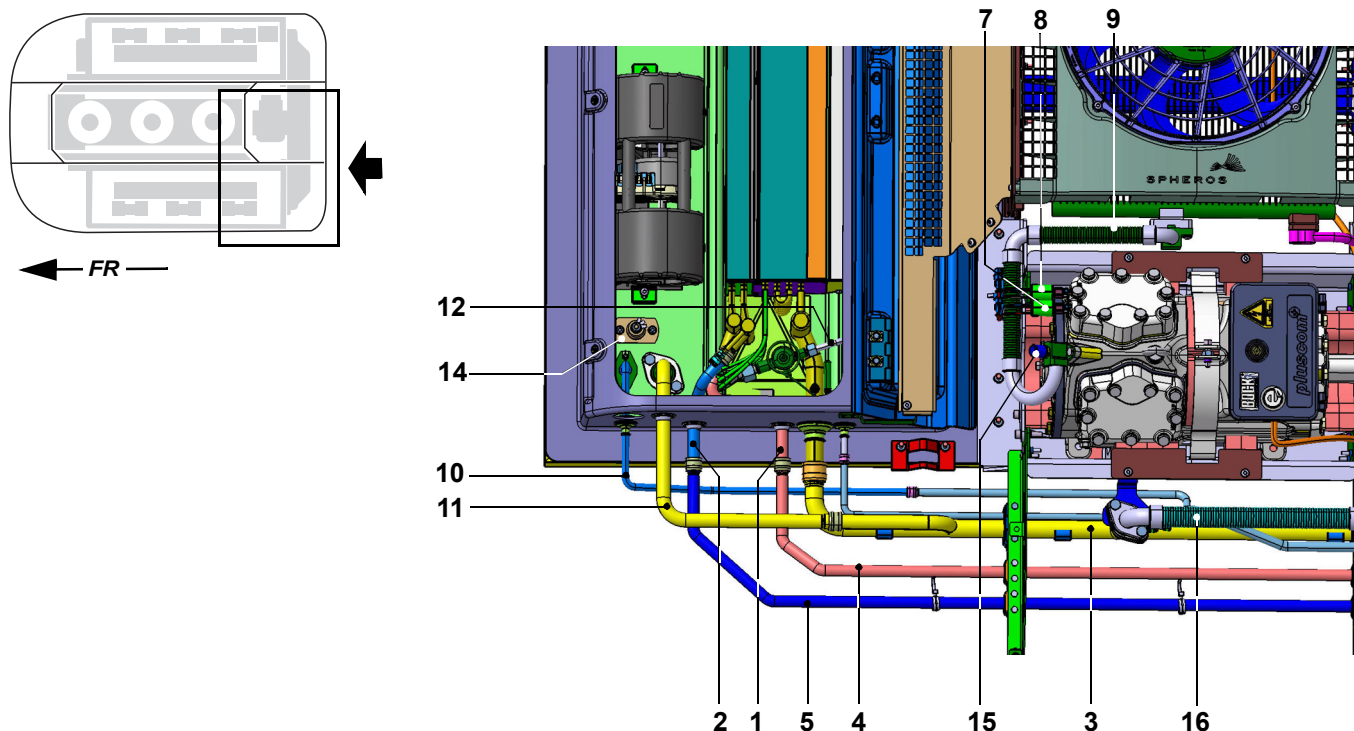

Pos./Item	Stück/Quantity			Bestell-Nr./Part. no.	Benennung	Description	Bemerkung/Remarks
	25kW	30kW	comp.				
Verrohrung / Piping							
1	1			---	Wasserleitung, Vorlauf, links	water line, feed flow, LH	enthalten in 11119064 bzw. 11119065; siehe Pos. 6 Seite 13/ contained in 11119064 resp. 11119065; see item 6 page 13 siehe auch Serviceinformation „Reparaturanweisung REVO“, Service-Koffer (LOKRING) notwendig /see also service information “REVO repair instruction”, service case (LOKRING) required
2	1			---	Wasserleitung, Rücklauf, links	water line, return, LH	
3	1	1	-	11116612A	Saugleitung 2	suction line 2	siehe auch Serviceinformation „Reparaturanweisung REVO“, Service-Koffer (LOKRING) notwendig /see also service information “REVO repair instruction”, service case (LOKRING) required
3	-	-	1	11121366A	Saugleitung 2	suction line 2	
4	1	1	-	11118860A	Wasserleitung 1	water line 1	siehe auch Serviceinformation „Reparaturanweisung REVO“, Service-Koffer (LOKRING) notwendig /see also service information “REVO repair instruction”, service case (LOKRING) required
4	-	-	1	11117922B	Wasserleitung 1	water line 1	
5	1	1	-	11118859A	Wasserleitung 2	water line 2	
5	-	-	1	11117911A	Wasserleitung 2	water line 2	
6 no fig.	1	1	-	11117347D	Kabelbaum, links	wiring harness, LH	
6 no fig.	-	-	1	11121430C	Kabelbaum, links	wiring harness, LH	
7	1	1	1	11114278B	Niederdruckwächter	low pressure switch	
8	1	1	1	11114279B	Hochdruckwächter	high pressure switch	
9	1	1	1	11116601B	Druckleitung, flexibel	pressure line, flexible	

Pos./Item	Stück/Quantity			Bestell-Nr./Part. no.	Benennung	Description	Bemerkung/Remarks
	25kW	30kW	comp.				
10	1	1	-	11116655A	Flüssigkeitsleitung, Slave	liquid line, slave	
10	-	-	1	11121465A	Flüssigkeitsleitung, Slave	liquid line, slave	
11	1	1	-	11116700A	Leitung, Rücklauf, Slave	line, return, slave	
11	-	-	1	11121367A	Leitung, Rücklauf, Slave	line, return, slave	
12	1	1	1	11116656B	Leitung, Verdampfer, links	line, evaporator, LH	
14	1	1	1	1103318A	Erdung (GND), Hochvoltkomponenten	grounding (GND), high voltage components	
15	1	1	1	80890A	Kältemittel-Füllventil, Druckseite	refrigerant charging valve, press. side	
16	1	1	1	11116600B	Saugleitung, flexibel	suction line, flexible	

Normteile ab Pos. 100 siehe Seite 17
Standard parts from item no. 100 - see page 17

Bild/fig. 7

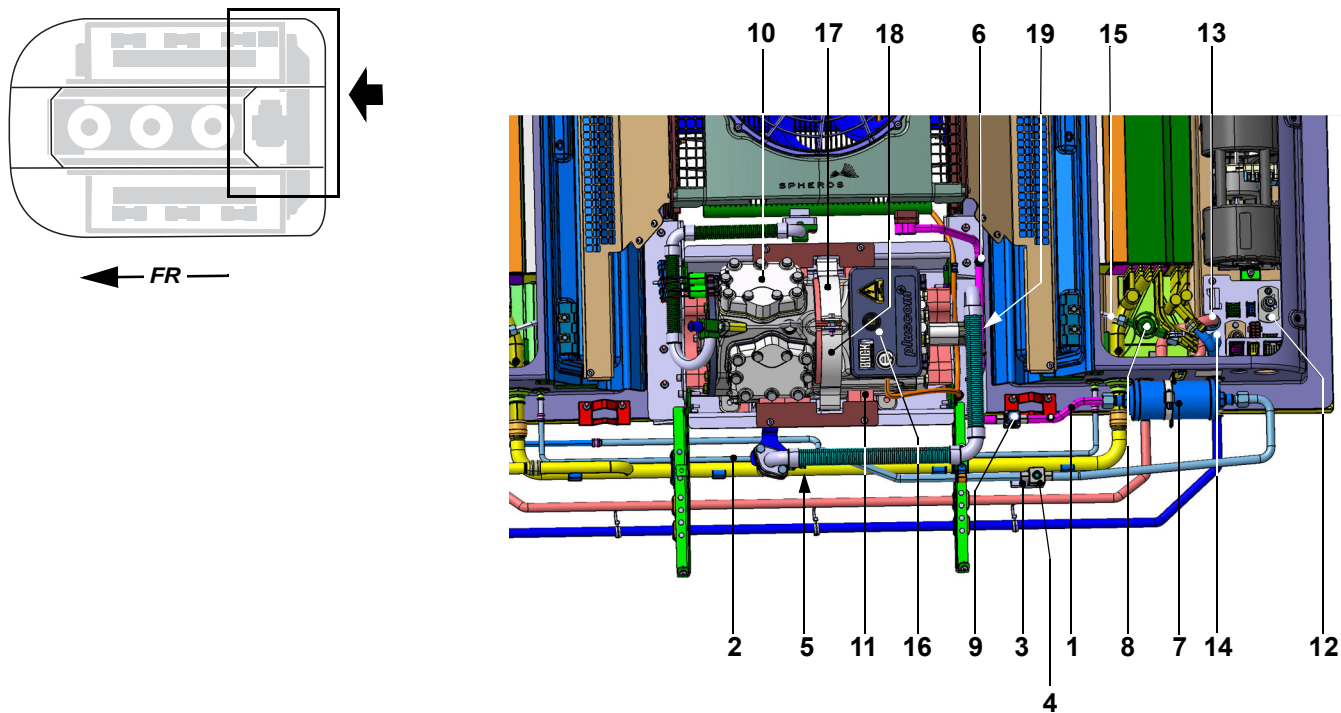

Pos./Item	Stück/Quantity			Bestell-Nr./Part. no.	Benennung	Description	Bemerkung/Remarks
	25kW	30kW	comp.				

Verrohrung, Verdichter, Elektrik / Piping, compressor, electrics

1	1	1	-	11116615B	Leitung, Unterkühler-Trockner	line, supercooler-dryer	O-Ring, Seite 17, Pos. 111 mitbestellen/ order also O-rings, page 17, item 111
	-	-	1	11121365A	Leitung, Unterkühler-Trockner	line, supercooler-dryer	
2	1	1	1	11116614B	Flüssigkeitsleitung	liquid line	siehe auch Serviceinformation „Reparaturanweisung REVO“, Service-Koffer (LOKRING) notwendig /see also service information “REVO repair instruction”, service case (LOKRING) required
3	1	1	1	1103673B	Einschraubventil, M25x1, stromlos	screw-in valve, M25x1 electroless	
4	1	1	1	1102620B	Spule, Magnetventil	coil, solenoid valve	
5	1	1	1	11118832A	Sensor Niederdruck	sensor low pressure	Saugdrucksensor in Saugleitung 2 / suction pressure sensor in suction pipe 2
6	1	1	1	11125858A	Überdruckventil	over pressure valve	
7	1	1	1	11117544A	Filtertrockner-Kit	filter drier kit	inkl. 2 O-Ringe / incl. 2 O-rings
8	2	-	2	11120166A	Expansionsventil	expansion valve	O-Ringe, Seite 17, Pos. 108, 109 (2ea) und 110 mitbestellen order also O-rings, page 17, items 108, 109 (2ea) and 110
8	-	2	-	11124195A	Expansionsventil	expansion valve	
9	1	1	1	1103672D	Absperrventil	shut-off valve	
10	1	1	1	11116620B	Verdichter	compressor	
11	1	1	1	11116676E	Lagerung, Verdichter	support, compressor	
12	1	1	-	11117326F	Kabelbaum, rechts	wiring harness, RH	
12	-	-	1	11121429B	Kabelbaum, rechts	wiring harness, RH	
13	1	-	-	---	Wasseranschluss, Vorlauf	water connection, feed flow	enthalten in 11119064 bzw. 11119065; siehe Pos. 6 Seite 13/ contained in 11119064 resp. 11119065; see item 6 page 13
13	-	1	-	11117909B	Wasseranschluss, Vorlauf	water connection, feed flow	--
13	-	-	1	11121117A	Wasseranschluss, Vorlauf	water connection, feed flow	--

Pos./Item	Stück/Quantity			Bestell-Nr./Part. no.	Benennung	Description	Bemerkung/Remarks
	25kW	30kW	comp.				
14	1	-	-	---	Wasseranschluss, Rücklauf	water connection, return	enthalten in 11119064 bzw. 11119065; siehe Pos. 6 Seite 13/ contained in 11119064 resp. 11119065; see item 6 page 13
14	-	1	-	11117908B	Wasseranschluss, Rücklauf	water connection, return	
14	-	-	1	11121118A	Wasseranschluss, Rücklauf	water connection, return	
15	1	1	1	11116657B	Leitung, Verdampfer, rechts	line, evaporator, RH	
16	1	1	1	11118576A	Vorreiberschlüssel, Klemmkasten	quarter lock key, terminal box	
17	1	1	1	11116836A	Halterung, Verdichter	support, compressor	ohne Einpressmutter/ w/o self-clinching nut
18	1	1	1	11117998A	Halterung, Verdichter	support, compressor	mit Einpressmutter/ with self-clinching nut
19	1	1	1	80891A	Kältemittel-Füllventil, Saugseite	refrigerant charging valve, suction side	

Normteile ab Pos. 100 siehe Seite 17
Standard parts from item no. 100 - see page 17

Bild/fig. 8

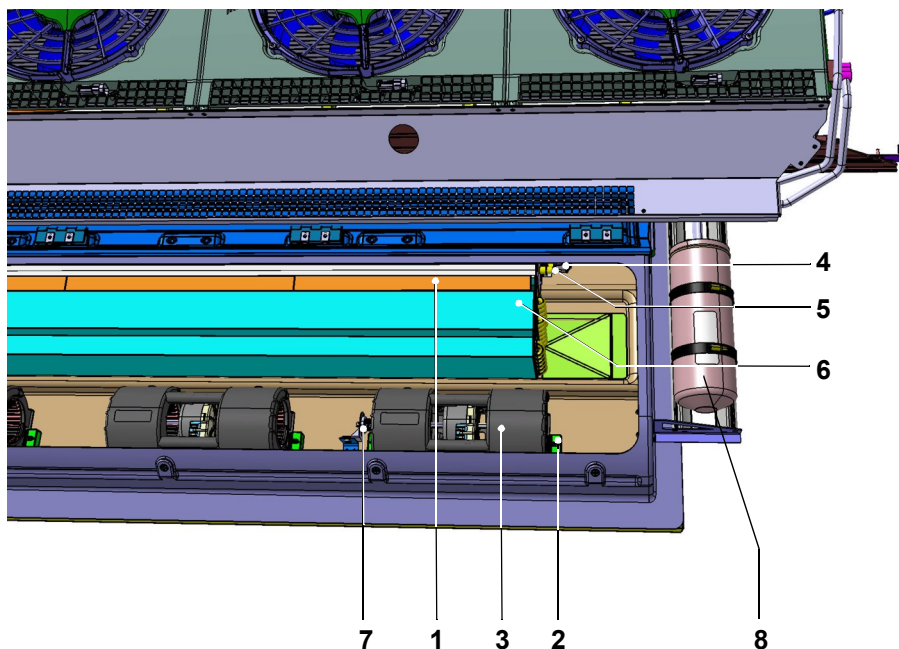
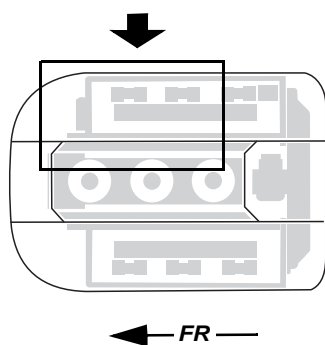

Pos./ Item	Stück/Quantity			Bestell-Nr./ Part. no.	Benennung	Description	Bemerkung/Remarks
	25kW	30kW	comp.				

Heizteil, Verdampfer / Heating element, evaporator

1	6	6	6	11139653A	Luftfilter	air filter	
1 no fig.	1	1	1	1102618B	Lifffilter-Kit	air filter kit	6 Stk. 11139653A im Karton / 6 ea 11139653A per box
2	12	12	12	1102026C	Klammer, Gebläse	clamp, fan	
3	6	6	6	11120703B	Gebläse, doppelradial	fan, double radial	
4	2	-	-	1104166C	Stellmotor	actuator	
4	-	2	2	11122733A	Stellmotor	actuator	
5	2			1102050B	Klappendämpfer	flap damper	
6	1	-	-	11119064A	Verdampfer / Heizteil links	evaporator / heating element LH	
6	-	1	1	11116618D	Verdampfer / Heizteil links	evaporator / heating element LH	siehe auch Serviceinformation „Repara- turanleitung REVO“, Service-Koffer (LOKRING) notwendig /see also ser- vice information "REVO repair instructi- on", service case (LOKRING) required
6	1	-	-	11119065A	Verdampfer / Heizteil rechts	evaporator / heating element RH	
6	-	1	1	11116619D	Verdampfer / Heizteil rechts	evaporator / heating element RH	
7	2	2	-	11117017A	Temperaturfühler	temperature sensor	Ausblasttemperatur/blow-out tempera- ture
8	1	1	1	11116914B	Kältemittelsammler	refrigerant collector	SMA-Anschluss / SMA connection Hinweis: ohne 11117038A O-Ring 11,0x2,5 / 1102134B Sicherungs- schraube M6x20 8.8 SW10 / Drehmo- ment Nm 9 ± 10% / Note: w/o 11117038A o-ring 11,0x2,5 / 1102134B safety screw M6x20 8.8 SW10 / torque Nm 9 ± 10%

Normteile ab Pos. 100 siehe Seite 17
Standard parts from item no. 100 - see page 17

REVO-E - Bild/fig. 9

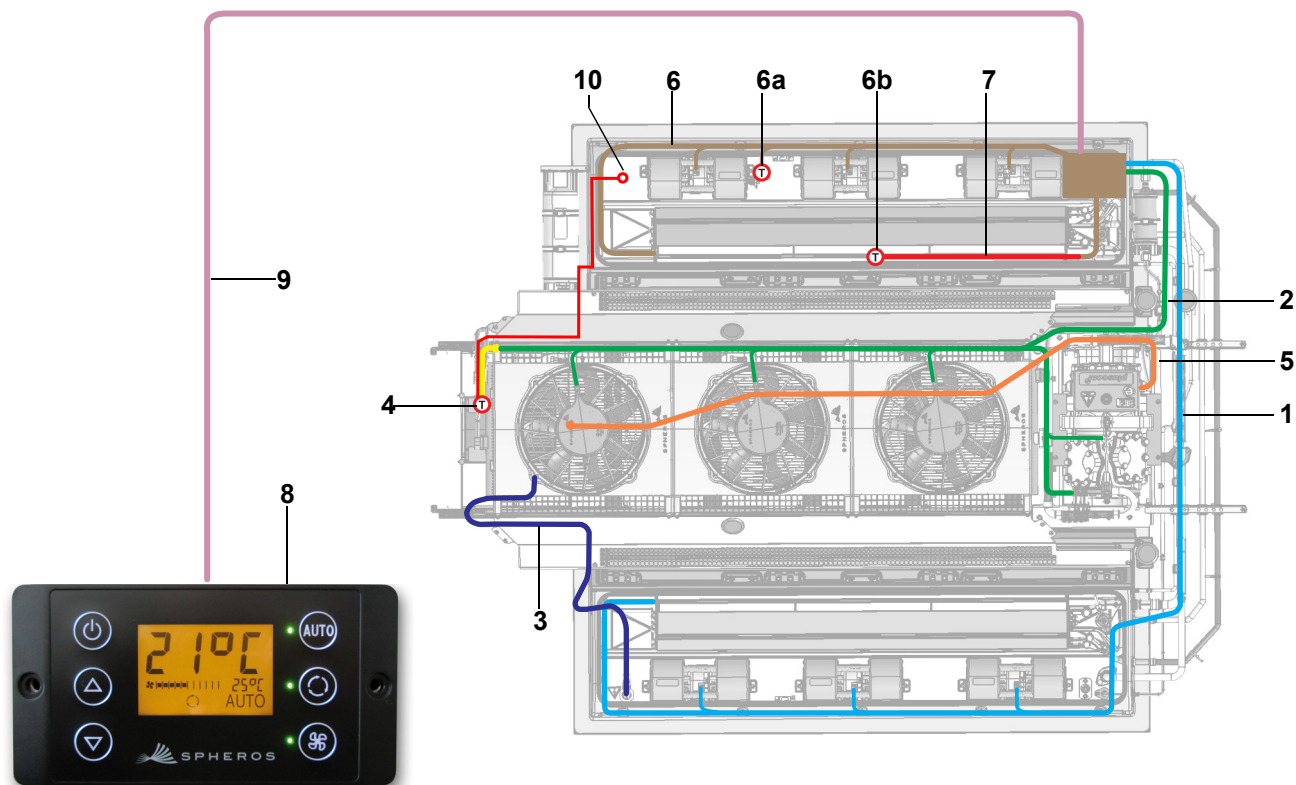

Pos./Item	Stück/Quantity			Bestell-Nr./Part. no.	Benennung	Description	Bemerkung/Remarks
	25kW	30kW	comp				

Elektrik / electrics

1	1	1	-	11117347D	Kabelbaum	wiring harness	Gebläse, Verdampfer, links/fan, evaporator, LH
1	-	-	1	11121430C	Kabelbaum	wiring harness	Gebläse, Verdampfer, links/fan, evaporator, LH
2	1	1	-	11117348F	Kabelbaum	wiring harness	Gebläse, Verflüssiger/fan, condenser
2	-	-	1	11121431B	Kabelbaum	wiring harness	Gebläse, Verflüssiger/fan, condenser
3	1	1	-	11117387E	Kabelbaum, 600V	wiring harness, 600V	HV-Schnittstelle, Fahrzeug - Inverter/high voltage interface, vehicle - inverter
4	1	1	-	11118837B	Sensor mit Kabelbaum	temperature sensor with wiring harness	für Kältemittel, Verflüssiger/for coolant, condenser
5	1	1	-	11122893A	Kabelbaum-Kit, 400V AC	wiring harness kit, 400V AC	Inverter - Verdichter/inverter - compressor inkl. Grundplatte / incl. base plate
6	1	1	-	11117326F	Kabelbaum inkl. Grundplatte	wiring harness incl. base plate	
6	-	-	1	11121429B	Kabelbaum inkl. Grundplatte	wiring harness incl. base plate	
6a	1	1	-	11117017A	Temperatursensor	temperature sensor	Ausblasttemperatur / blow-out temperature
6b	1	1	-	11117017A	Temperatursensor	temperature sensor	Innenraum / pass. compartment
7	1	1	-	11118302A	Kabelbaum, Innenraumsensor	wiring harness, temperature sensor passenger compartment	
8	1	1	-	11117650D	SC600 Steuergerät Volvo EU6	SC600 control device, Volvo EU6	EU6 (Euro 6)
8	1	1	-	11117549H	SC600 Steuergerät GH	SC600 control device GH	GH (Global Hybrid)

Pos./Item	Stück/Quantity			Bestell-Nr./Part. no.	Benennung	Description	Bemerkung/Remarks
	25kW	30kW	comp				
9	1	1	-	11117846E	Kabelbaum SC600 zu REVO E, 11m	wiring harness SC600 to REVO E, 11m	
10	1	1	-	11124115B	Diagnosekabel mit Stecker M12x1 gerade (w)	diagnose cable with plug M12x1 straight (F)	
11 no fig.	1	-	-	11117364B	Kabelbaum zwischen Master und Slave	wiring harness between master and slave	nur Gelenkzugausführung/ articulated buses only

Normteile ab Pos. 100 siehe Seite 17
Standard parts from item no. 100 - see page 17

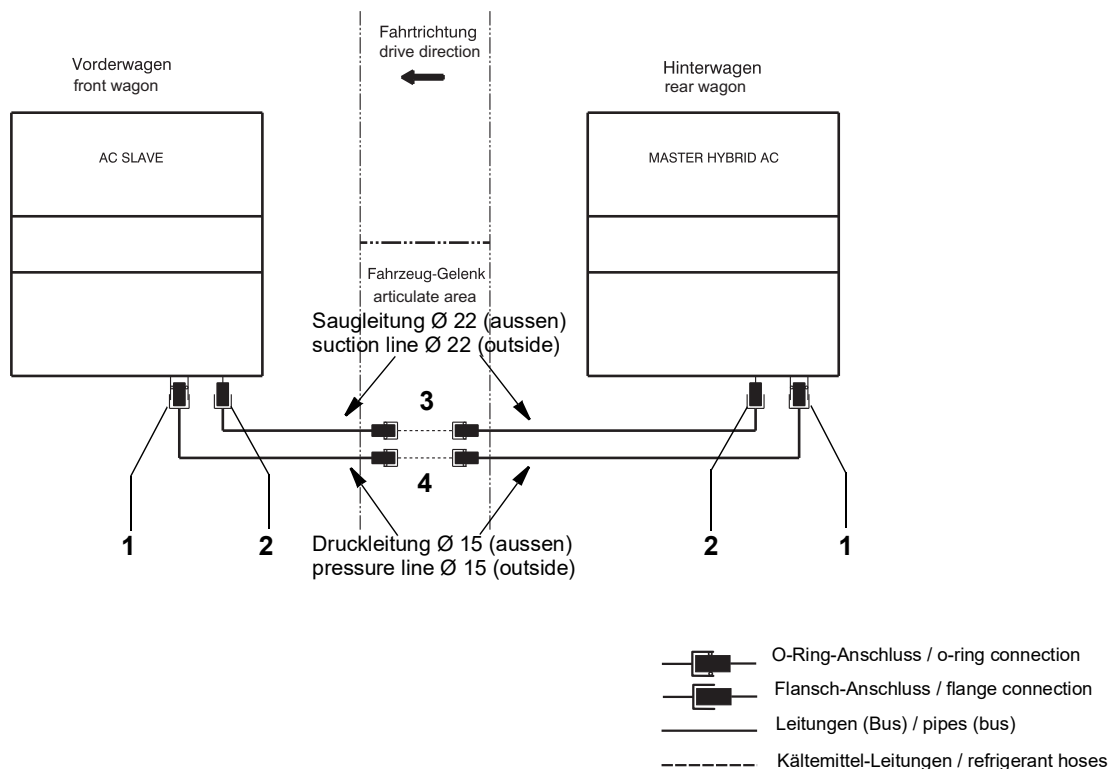

Pos./ Item	Stück/Quantity			Bestell-Nr./ Part. no.	Benennung	Description	Bemerkung/ Remarks	Pos./Item
	25kW	30kW	comp.					

Zubehör Kit / accessory kit

1	2	-	-	24674A	Lötbuchse (O-Ring), Druckleitung	soldered bush (o-ring), pressure line		Master & Slave
1	2	-	-	80641A	O-Ring, Druckleitung	o-ring, pressure line		Master & Slave
1	2	-	-	24663B	Mutter, Kupplung, 7/8" -14UNF	nut, coupling, 7/8" -14UNF		Master & Slave
1	2	-	-	33476B	Mutter, M10x8	nut, M10x8		wiederverw. von dergelieferten Anlage (Schließplatte) reuse from delivered unit (closing plate)
2	2	-	-	25896B	Lötbuchse NW20 (Flansch), Saugleitung	soldered bush NW20 (flange), suction line		Master & Slave
2	2	-	-	23367B	Flansch (ohne Gewinde)	flange (w/o thread)		Master & Slave
2	2	-	-	24632A	Dichtung	gasket		Master & Slave
3	1	-	-	11118349A	Saugleitung, ZSB, NW20	suction hose, assy, NW20		Gelenkbereich unten articulate bellow
3	2	-	-	11118355A	Lötbuchse, Saugleitung	soldered bush, suction hose		Gelenkbereich unten articulate bellow
4	1	-	-	11118348A	Druckleitung, ZSB, NW13	pressure hose, assy, NW13		Gelenkbereich unten articulate bellow
4	2	-	-	45399A	Lötbuchse, Druckleitung	soldered bush, pressure hose		Gelenkbereich unten articulate bellow

Pos./ Item	Stück/Quantity			Bestell-Nr./ Part. no.	Benennung	Description	Bemerkung/Remarks
	25kW	30kW	comp.				
Normteile / Halbzeuge / standard parts / semi-finished parts							
105 no fig.	1	1	1	11115563A	Schraube Torx	screw Torx head	
106 no fig.	10	10	10	68579B	Schraube, Flachkopf, DIN 921 M6x20-8.8	screw, flat head, DIN 921 M6x20-8.3	
107 no fig.	10	10	10	68557A	Unterlegscheibe, D6/020, PA6 natur	washer, D6/020, PA6 nature	
108 no fig.	1	1	1	80812A	O-Ring, 134A beständig	o-ring, R134A-resistant	
109 no fig.	2	2	2	80640A	O-Ring, 134A beständig	o-ring, R134A-resistant	
110 no fig.	1	1	1	1103522A	O-Ring, 134A beständig	o-ring, R134A-resistant	
111 no fig.	7	7	7	80641A	O-Ring, 134A beständig	o-ring, R134A-resistant	
112 no fig.	1	1	1	69052A	O-Ring, 134A beständig	o-ring, R134A-resistant	
113 no fig.	1	1	1	1102134B	Sicherungsschraube M6x20 8.8 SW10	safety screw M6x20 8.8 SW10	Flansch Sammler flange collector
114 - 118							
119 no fig.	x	x	x	11117080A	Service-Koffer (LOKRING)	service case (LOKRING)	
120 no fig.	x	x	x	11118861A	LOKRING, Kupplung Ø 10	LOKRINGcoupling, Ø 10	
121 no fig.	x	x	x	11116888A	LOKRING, Kupplung Ø 12	LOKRINGcoupling, Ø 12	
122 no fig.	x	x	x	11116889A	LOKRING, Kupplung Ø 18	LOKRINGcoupling, Ø 18	
123 no fig.	x	x	x	11118872A	LOKRING, Kupplung Ø 22	LOKRINGcoupling, Ø 22	
124 no fig.	x	x	x	11116890A	LOKRING, Kupplung Ø 28	LOKRINGcoupling, Ø 28	
125 no fig.	x	x	x	11115842B	LOKPREP 65G	LOKPREP 65G	Dichtmittel sealing material, 15 ml

x = Stückzahl nach Bedarf / quantity as required

