



PARTS & SERVICE

Klimaanlage
Air conditioning system

Ersatzteil-Liste
Spare parts list

REVO®
Scania Omni Express

REVO® 280 / 360 / 400
REVO® 360 NBG / REVO HV
REVO® ART MASTER NBG /
REVO® ART SLAVE

REVO-Baukasten / REVO construction kit

REVO-Varianten - Technische Daten im Überblick / REVO Variants - Technical data at a glance

Technische Daten/ Technical data	REVO 280 11116119_	REVO 360 11115784_	REVO 400 11125951_
Max. Kälteleistung/ Max. refrigerating capacity (kW)	30	32/36	40
Luftvolumenstrom/Air flow volume (freiblasend/free-blowing, m ³ /h)	4.640	6.960	9.280
Heizleistung/Heating capacity (kW)	40	40	40
Max. Betriebstemperatur/Max. operating temperature (°C)	52	52/50	55
Max. Stromaufnahme/ Power consumption	72A	89A	99A
Kompressor/Compressor (cm ³)	470	470/560	655
Kältemittel (FCKW-frei)/ Refrigerant (CFC-free)	R134a	R134a	R134a
Gewicht/Weight (kg)	124	129	162
Abmessungen LxBxH/ Dimensions LxWxH (mm)	2.593x 2.077 x 215	2.593 x 2.077 x 215	3.113 x 2.077 x 215

Technische Daten/ Technical data	REVO 360 NBG 11137536_	REVO HV 11115924_ 1)	REVO ART Master NBG 11137761C	REVO ART Slave NBG 11137762B
Max. Kälteleistung/ Max. refrigerating capacity (kW)	32/36	--	21	21
Luftvolumenstrom/Air flow volume (freiblasend/free-blowing, m ³ /h)	6.960	6.960	6.960	6.960
Heizleistung/Heating capacity (kW)	36	40	36	36
Max. Betriebstemperatur/Max. operating temperature (°C)	52/50	--	45	45
Max. Stromaufnahme/ Power consumption	89A	60A	100A	60A
Kompressor/Compressor (cm ³)	560	--	655	--
Kältemittel (FCKW-frei)/ Refrigerant (CFC-free)	R134A	R134a	R134a	R134a
Gewicht/Weight (kg)	130	105	134	110
Abmessungen LxBxH/ Dimensions LxWxH (mm)	2594x2080x215	2.593 x 2.077 x 215	2.594 x 2.080 x 215	2.594 x 2.080 x 215

1) REVO HV, Heating-Ventilation Version (ohne Kühlfunktion)/(without cooling function)

Inhalt/Content:

Übersicht/Overview REVO 280/360/400	Bild/fig. 1
Übersicht/Overview REVO 360 NBG / REVO HV	Bild/fig. 2
Übersicht/Overview REVO ART Master NBG / ART Slave NBG	Bild/fig. 3
Haube/Cover	Bild/fig. 4
Verflüssiger / Axialgebläse / condenser / axial fan	Bild/fig. 5
Kältemittelsammler / refrigerant receiver	Bild/fig. 6
Verrohrung / piping	Bild/fig. 7
Verrohrung / piping	Bild/fig. 8
Verrohrung / piping	Bild/fig. 9
Heizteil / Verdampfer / heating element / evaporator	Bild/fig. 10
Elektrik / electrics	Bild/fig. 11
Normteile, Halbzeuge / standard parts, semi-finished parts	Seite/page 17

Notwendige Angaben zur schnellen Ersatzteilermittlung: / Required data for quick spare part identification:

- Klimaanlage typ: z.B. REVO 360 /
- A/C unit model: e.g. REVO 360
- Spheros-Identnummer: z.B. 11115784A
- Spheros ID: e.g. 11115784A
- Produktionsdatum: z.B. 20141024/
- Date of production: e.g. 20141024
- Seriennr.: z.B. 14182756/
- Serial no.: e.g. 14182756

Hinweis: Die Position des Typschildes ist aus Bild 1 auf Seite 3 (Pos. 25) ersichtlich.

Note: For model plate position, refer to fig. 1 on page 3 (item 25).

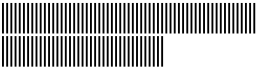
 E1 10R-03 6176	
Made in Germany	
Model	REVO 360
Spheros ID	11115784A
Customer ID	
P COOLING / P HEATING	32KW / 38KW
VOLTAGE	24V
REFRIGERANT / OIL TYPE	R134a / Ester
COOLANT	Water / Glycol
MAX. PRESSURE / A/C-H	25 bar / 2 bar
Serial No./Date of Prod.	14182756 / 20141024
	
Year of Initiating	2017 2018 2019

Hinweis: Beim Eintrag „Service Info“ in der Spalte Bemerkungen, siehe auch Serviceinformation „Reparaturanweisung REVO“, Valeo Service-Koffer (LOKRING) (Pos. 119 notwendig).

Note: If the entry „Service Info“ is in the column Remarks, see also service information „REVO Repair instruction“, Valeo service case (LOKRING) (item 119 required).

Hinweis: Nach rechts eingerückte Teile bzw. Untergruppen (durch Punkte markiert) sind in den um einen Punkt weniger eingerückten Baugruppen enthalten.

Note: Sub-assemblies or components (marked by a point) - offset to the right - are contained in the assembly which is offset one point less.

Änderungen vorbehalten. Im Fall einer mehrsprachigen Version ist Deutsch verbindlich. Die aktuelle Fassung dieser Ersatzteilliste steht unter www.valeo-thermalbus.com zum Download bereit. / Subject to modification. In multilingual versions the German language is binding. Latest version of this spare parts list is provided for download on www.valeo-thermalbus.com.

REVO 280/360/400 Übersicht / Overview - Bild/fig. 1

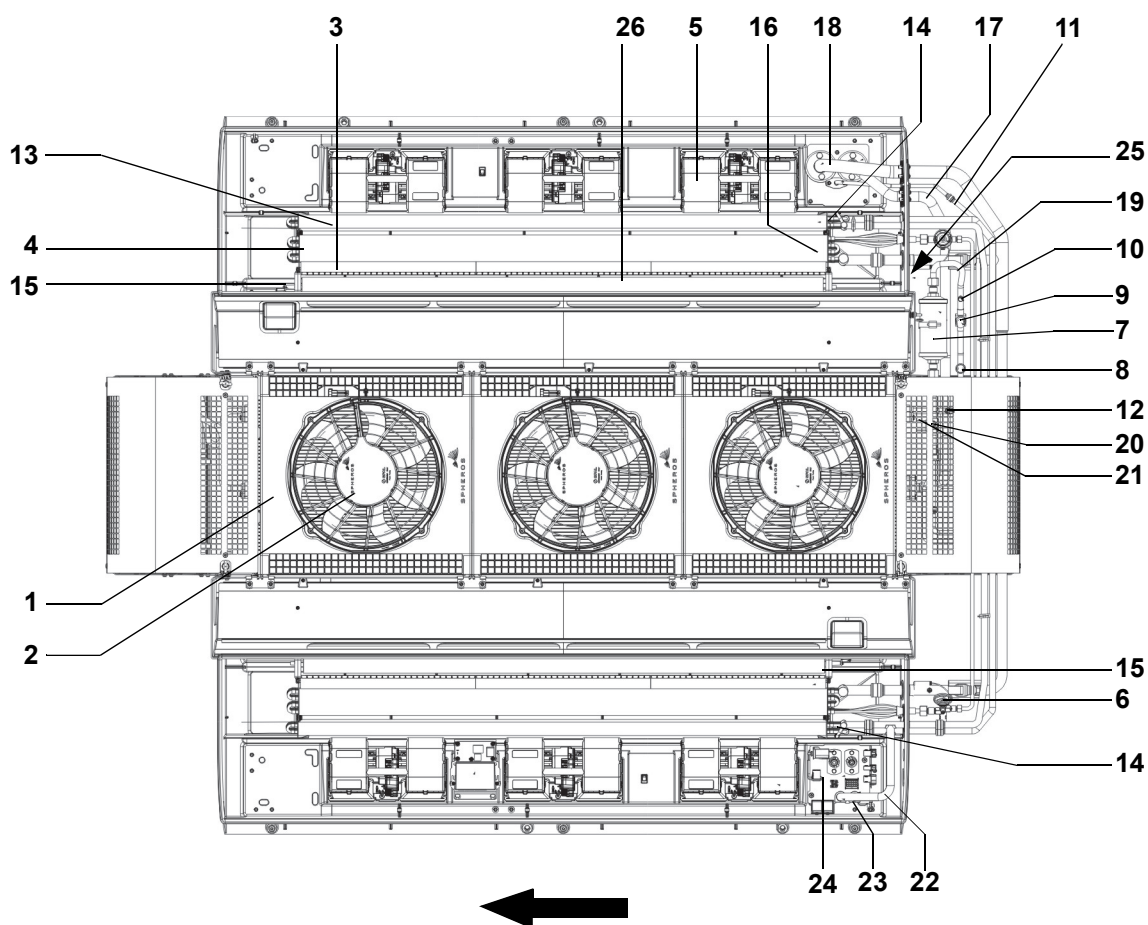

- | | | | |
|---|---|--|---|
| 1 Verflüssiger | 15 Stellmotor, Klappe, Frischluft/Umluft | 1 condenser | 15 actuation motor, flap, fresh air / circulating air |
| 2 Lüfter, Verflüssiger | 16 Thermostat, Vereisungsschutz | 2 fan, condenser | 16 thermostat, icing protection |
| 3 Filter, Frischluft / Umluft | 17 Druckleitung | 3 filter, fresh air / circulating air | 17 pressure line |
| 4 Verdampfer | 18 Saugleitung | 4 evaporator | 18 suction line |
| 5 Gebläse, Verdampfer | 19 Kältemittelleitung, Filter-trockner - Verflüssiger | 5 fan, evaporator | 19 refrigerant line, filter drier - condenser |
| 6 Expansionsventil | 20 Schauglas | 6 expansion valve | 20 sight glas |
| 7 Filtertrockner | 21 Magnetventil | 7 filter drier | 21 solenoid valve |
| 8 Druckschalter, Lüfter, Verflüssiger (halb / voll) | 22 Wasserrücklauf | 8 pressure switch, fan, condenser (50% / max.) | 22 water return |
| 9 Serviceabsperreschieber | 23 Wasservorlauf | 9 service shut-off valve | 23 Water feed flow |
| 10 Serviceanschluss | 24 Elektrische Schnittstelle mit Sicherungen | 10 service interface | 24 electrical interface with fuses |
| 11 Frontboxleitung | 25 Typschild | 11 frontbox pipe | 25 model plate |
| 12 Sicherheitsventil, 30 bar | | 12 safety valve, 30 bar | |
| 13 Wärmetauscher | | 13 heat exchanger | |
| 14 Entlüftungsventil, Wärmetauscher | | 14 vent valve, heat exchanger | |

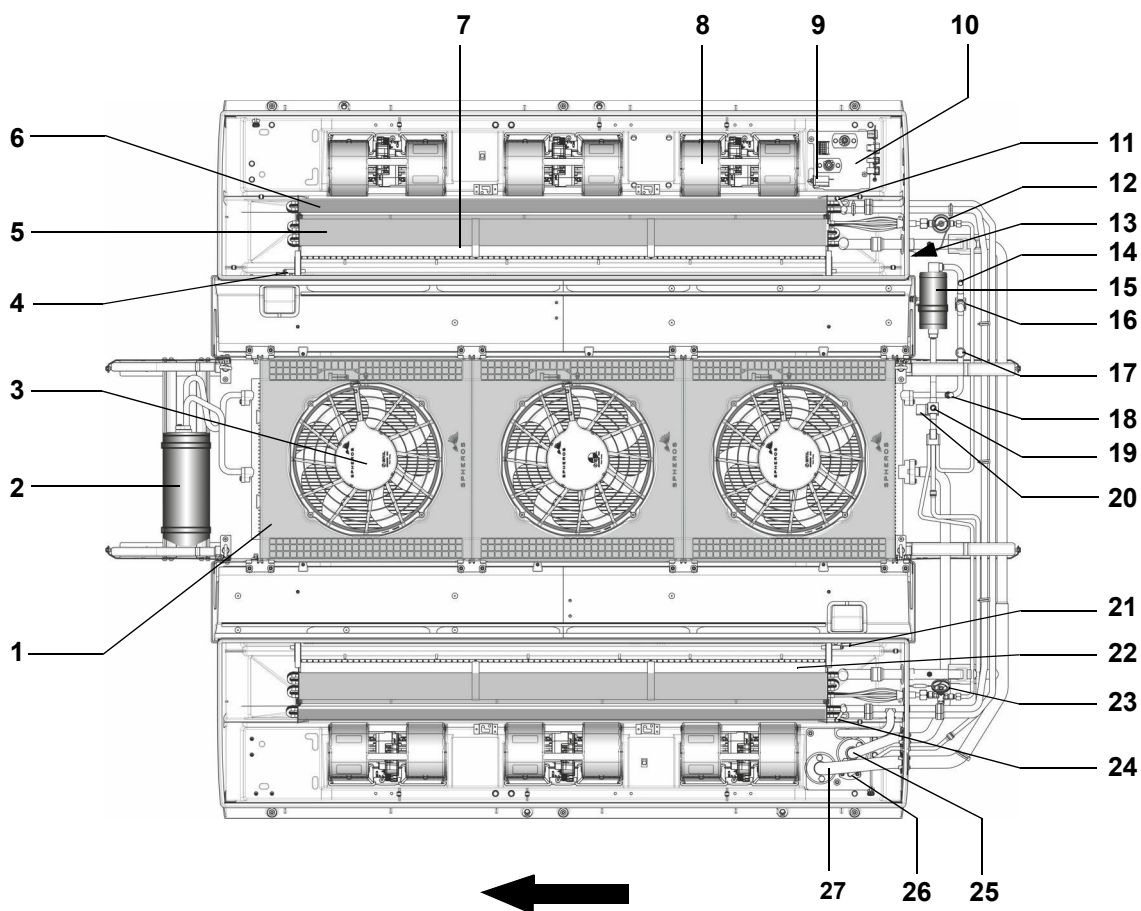

- | | | | |
|--|--------------------------------|------------------------------------|-------------------------------|
| 1 Verflüssiger | 14 Kältemittel-Füllventil | 1 condenser | 14 refrigerant charging valve |
| 2 Kältemittelsammler | 15 Filtertrockner | 2 refrigerant collector | 15 filter drier |
| 3 Lüfter, Verflüssiger | 16 Absperrventil | 3 fan, condenser | 16 stop valve |
| 4 Klappenstellmotor4 | 17 Druckschalter | 4 flap servo motor | 17 pressure switch |
| 5 Verdampfer | 18 Sicherheitsventil, 30 bar | 5 evaporator | 18 safety valve, 30 bar |
| 6 Wärmetauscher | 19 Schauglas | 6 heat exchanger | 19 sight glass |
| 7 Luftfilter | 20 Magnetventil | 7 air filter | 20 solenoid valve |
| 8 Gebläse, Verdampfer | 21 Klappenstellmotor, verdeckt | 8 fan, evaporator | 21 flap servo motor (hidden) |
| 9 Thermostat Vereisungsschutz | 22 Luftfilter | 9 thermostat, icing protection | 22 air filter |
| 10 Elektrische Schnittstelle mit Sicherungen | 23 Expansionsventil | 10 electrical interface with fuses | 23 expansion valve |
| 11 Entlüftung Heizteil | 24 Entlüftung Heizteil | 11 vent valve, heater | 24 vent valve, heater |
| 12 Expansionsventil | 25 Druckleitung | 12 expansion valve | 25 pressure line |
| 13 Position Typschild | 26 Frontboxanschluss | 13 position type label | 26 frontbox pipe |
| | 27 Saugleitung | | 27 suction line |

REVO ART Master NBG / ART Slave NBG - Bild/fig. 3

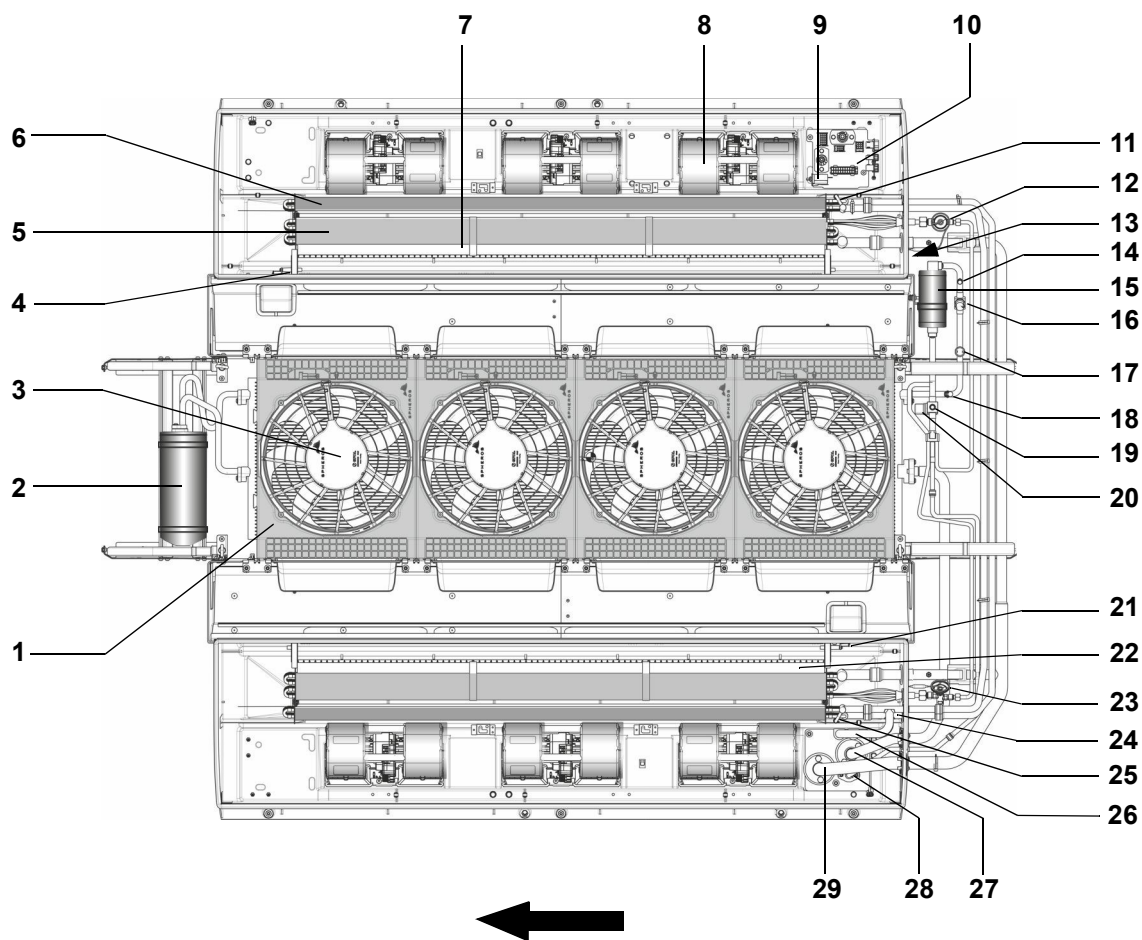

- | | | | |
|--|--------------------------------|------------------------------------|------------------------------|
| 1 Verflüssiger | 15 Filtertrockner | 1 condenser | 15 filter drier |
| 2 Kältemittelsammler | 16 Absperrventil | 2 refrigerant collector | 16 stop valve |
| 3 Lüfter, Verflüssiger | 17 Druckschalter | 3 fan, condenser | 17 pressure switch |
| 4 Klappenstellmotor | 18 Sicherheitsventil, 30 bar | 4 flap servo motor | 18 safety valve, 30 bar |
| 5 Verdampfer | 19 Schauglas | 5 evaporator | 19 sight glass |
| 6 Wärmetauscher | 20 Magnetventil | 6 heat exchanger | 20 solenoid valve |
| 7 Luftfilter | 21 Klappenstellmotor, verdeckt | 7 air filter | 21 flap servo motor (hidden) |
| 8 Gebläse, Verdampfer | 22 Luftfilter | 8 fan, evaporator | 22 air filter |
| 9 Thermostat Vereisungsschutz | 23 Expansionsventil | 9 thermostat, icing protection | 23 expansion valve |
| 10 Elektrische Schnittstelle mit Sicherungen | 24 Wasservorlauf | 10 electrical interface with fuses | 24 water flow |
| 11 Entlüftung Heizteil | 25 Entlüftung Heizteil | 11 vent valve, heater | 25 vent valve, heater |
| 12 Expansionsventil | 26 Wasserrücklauf | 12 expansion valve | 26 water return |
| 13 Position Typschild | 27 Druckleitung | 13 position type label | 27 pressure line |
| 14 Kältemittel-Füllventil | 28 Anschluss Slave-Anlage | 14 refrigerant charging valve | 28 connection to slave unit |
| | 29 Saugleitung | | 29 suction line |

Normteile ab Pos. 100 siehe Seite 17
Standard parts from item no. 100 - see page 17

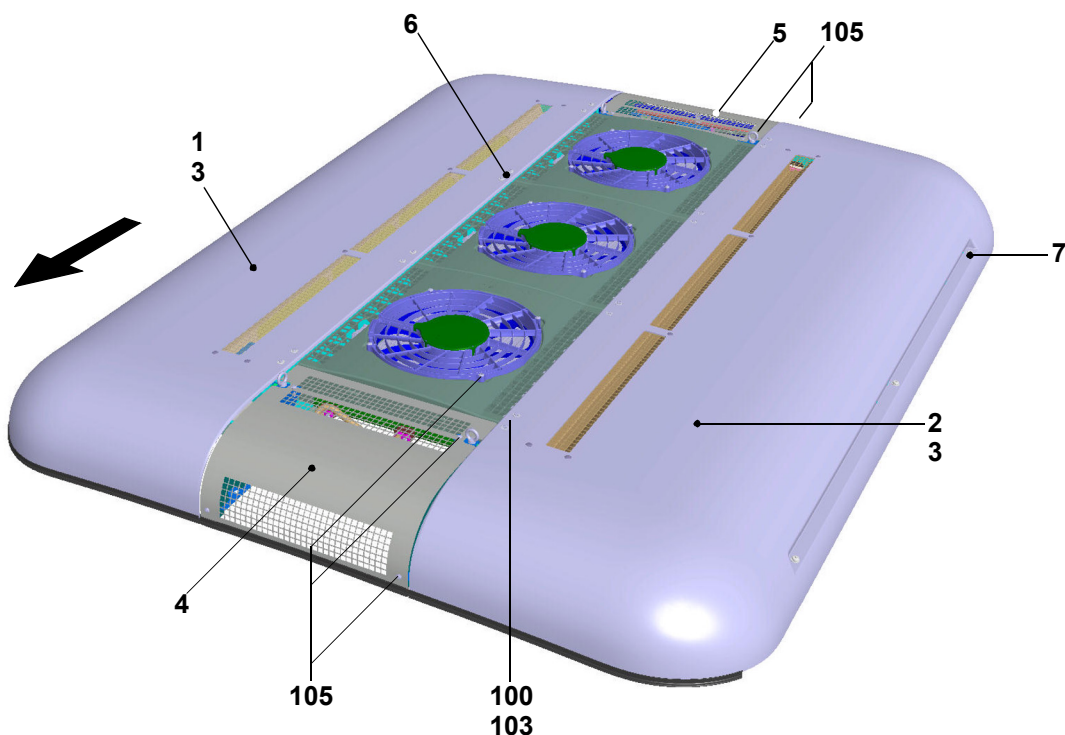

Hinweis: Abgebildet ist die REVO 360. / Note: REVO 360 is shown.

Pos./ Item	Stück/Quantity REVO							Bestell-Nr./ Part. no.	Benennung	Description	Bemerkung/Remarks
	280	360	400	360 NBG	HV	Art Master	Art Slave				
Haube / Cover											
1	1	1		1	1		1	11115825A	Haube rechts, ZSB	cover RH, assy	
1							1	11118752A	Stadtbushaube rechts, ZSB	cover city bus RH, assy	abhängig von der Aufbaurichtung / depending on installation direction
2	1	1		1	1		1	11115824A	Haube links, ZSB	cover LH, assy	
2							1	11118751A	Stadtbushaube links, ZSB	cover city bus LH, assy	
3			2					1120688B	Haube rechts/links, ZSB	cover assy, LH/RH	
4	1	1		1	1	1	1	11115293C	Haube vorn/hinten	cover, front/rear	
5	1	1	2	1	1	1	1	11115292C	Haube hinten	cover, rear	
6	8	8	10	8	8	10	8	11115055C	Haubenscharnier	hinge, cover	
7	1	1	1	1	1	1	1	11121596A	Haubenschrauben REVO 8x M8x25	cover screws REVO 8ea M8x25	Kit, enthält 8 Schrauben und Scheiben, Schrauben mit 10Nm anziehen! / Kit, contains 8 screws and was- hers, Torque screws to 10Nm! 

Normteile ab Pos. 100 siehe Seite 17
Standard parts from item no. 100 - see page 17

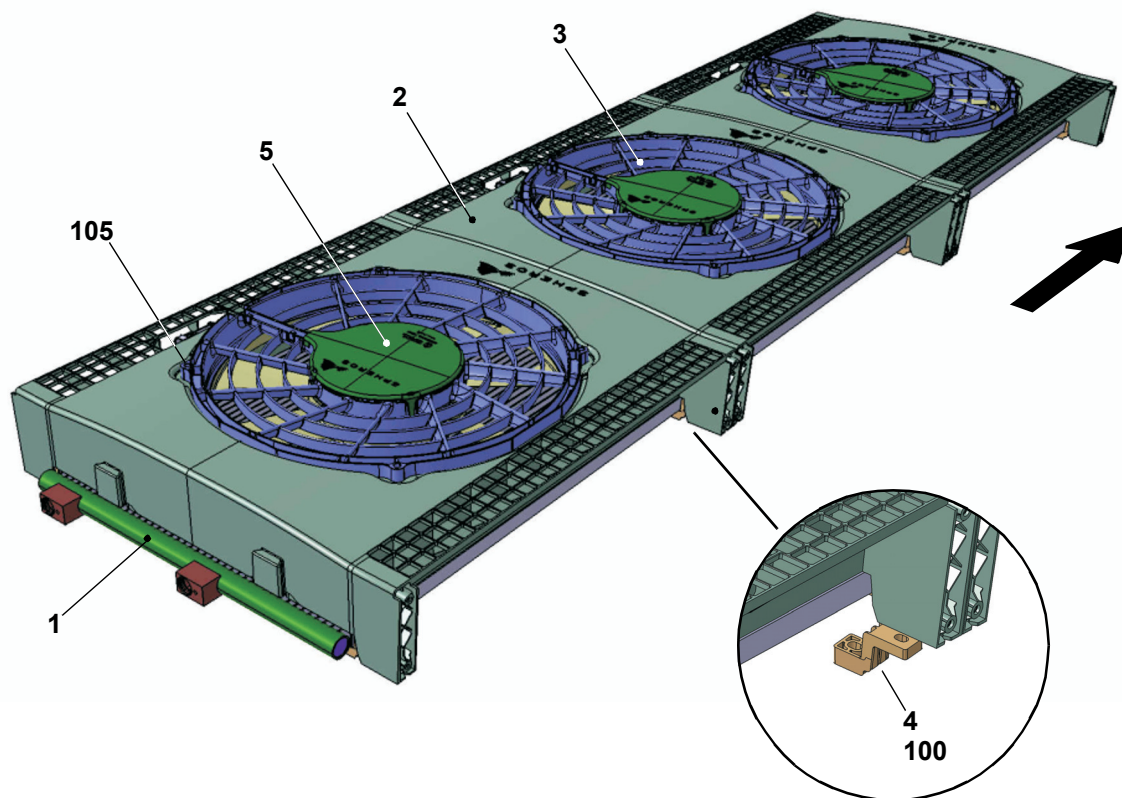

Hinweis: Abgebildet ist die REVO 360. / Note: REVO 360 is shown.

Pos./ Item	Stück/Quantity REVO						Bestell-Nr./ Part. no.	Benennung	Description	Bemerkung/Remarks
	280	360	400	360 NBG	HV	Art Master				
Verflüssiger / Axialgebläse / condenser / axial fan										
1	1	1		1		1	11122551A	Verflüssiger, 1900 mm	condenser, 1900 mm	
1			1				11122552A	Verflüssiger, 2500 mm	condenser, 2500 mm	
2	3	3	4	3	3	3	11114821A	Axialgebläsemodul, 600 mm	axial fan module, 600 mm	
2					3	3	11116215A	Deckel, Lüftermodul	cover, fan module	
2						4	11115679A	Axialgebläsemodul, 450 mm	axial fan module, 450 mm	
3	3	3	4	3		4	11122719A	Axialgebläse, 405 mm	axial fan, 405 mm	Ersatz für / replaces 11114716C
4	12	12	16	12		16	11114857C	Klammer, Verflüssiger	clamp, condenser	

Normteile ab Pos. 100 siehe Seite 17
Standard parts from item no. 100 - see page 17

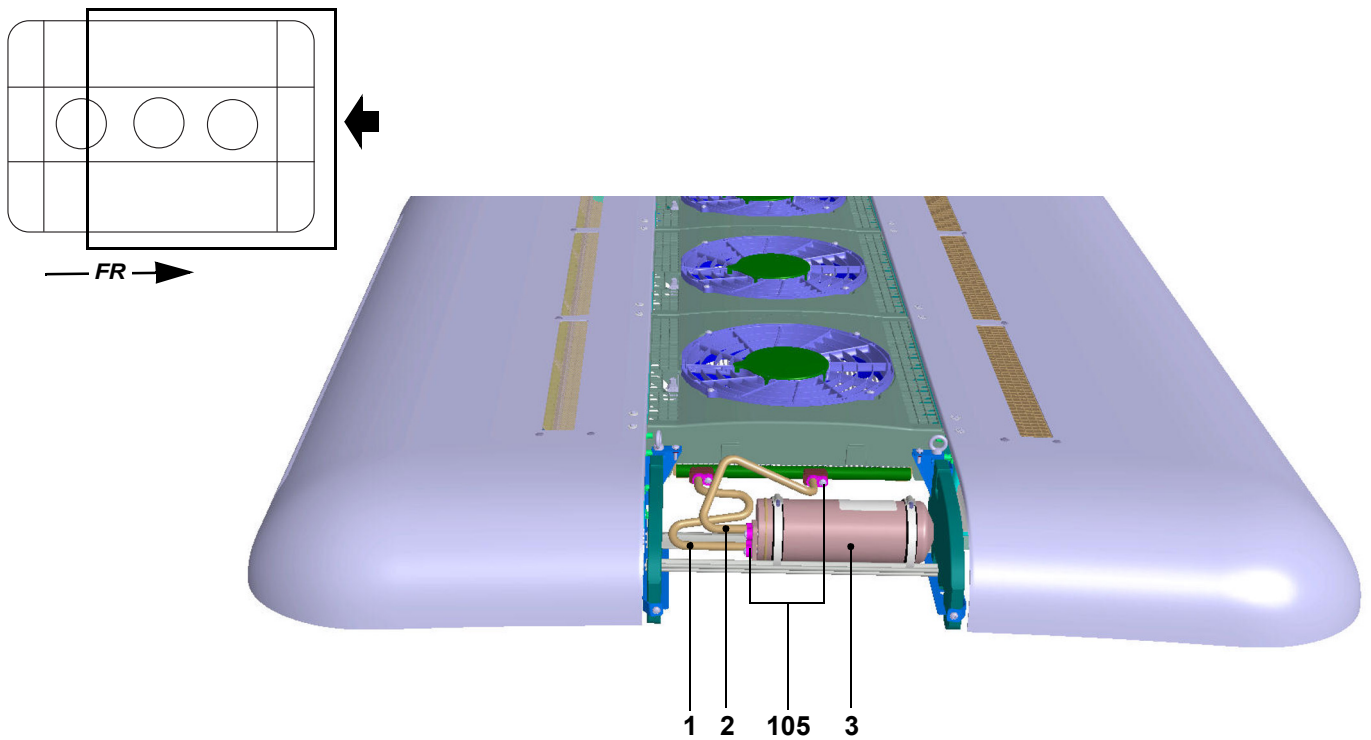

Hinweis: Abgebildet ist die REVO 360. / Note: REVO 360 is shown.

Pos./ Item	Stück/Quantity REVO							Bestell-Nr./ Part. no.	Benennung	Description	Bemerkung/Remarks
	280	360	400	360 NBG	HV	Art Master	Art Slave				
Kältemittelsammler / refrigerant receiver											
1	1	1	1	1		1		11115777A	Leitung, Sammler-Unterkühler	line, receiver-super cooler	ab/from 03/2013 inkl. 2 O-Ringe, Pos. 112 / incl. 2 o-rings, item 112
2	1	1	1	1		1		11115776A	Leitung, Verflüssiger-Sammler	line, condenser-receiver	ab/from 03/2013 inkl. 2 O-Ringe, Pos. 112 / incl. 2 o-rings, item 112
3	1	1	1	1		1		11116914A	Kältemittelsammler	refrigerant receiver	ab/from 03/2013 2 O-Ringe, Pos. 112 mitbe- stellen / order also 2 o-rings, item 112

Normteile ab Pos. 100 siehe Seite 17
Standard parts from item no. 100 - see page 17

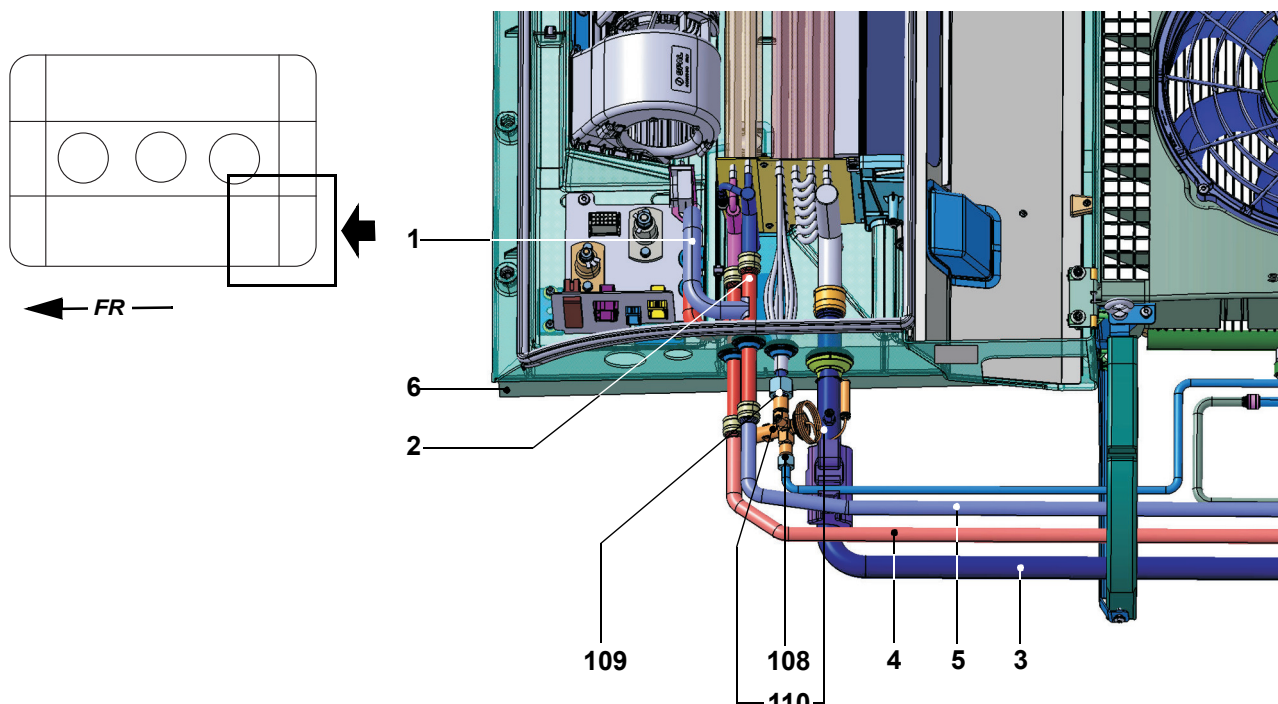

Hinweis: Abgebildet ist die REVO 360. / Note: REVO 360 is shown.

Pos./ Item	Stück/Quantity REVO							Bestell-Nr./ Part. no.	Benennung	Description	Bemerkung/Remarks
	280	360	400	360 NBG	HV	Art Master	Art Slave				

Verrohrung / piping

1	1	1			1			11116352A	Wasserleitung, Vorlauf	waterline, feed flow	
1			1			1	1	11116466A	Wasserleitung, Vorlauf	waterline, feed flow	
1				1				11114989B	Wasseranschluss, Vorlauf LH	water port, feed flow LH	
2	1	1			1			11116353A	Wasserleitung, Rücklauf	waterline, return	siehe auch Serviceinformation „Reparaturanweisung REVO“, Spheros Service-Koffer (LO-KRING) (Pos. 119) notwendig / see also service information “REVO Repair instruction“, Spheros service case (LO-KRING) (item 119) required
2			1			1	1	11116465A	Wasserleitung, Rücklauf	waterline, return	
2				1				11114986A	Wasseranschluss, Rücklauf LH	water port, return LH	
3	1	1	1					11115808C	Saugleitung	suction line	
3				1		1	1	11117488B	Saugleitung LH	suction line LH	
4	1	1			1			11116359A	Wasserrohr, D18, Vorlauf	water pipe, D18, feed flow	
4				1				11114990A	Wasserrohr, D18, Vorlauf	water pipe, D18, feed flow	
4						1	1	11116464B	Wasserrohr, D18, Vorlauf	water pipe, D18, feed flow	
5	1	1			1			11116360A	Wasserrohr, D18, Rücklauf	water pipe, D18, return	
5						1	1	11116463B	Wasserrohr, D18, Rücklauf	water pipe, D18, return	
5				1				11114985A	Wasserrohr, D18, Rücklauf	water pipe, D18, return	

Normteile ab Pos. 100 siehe Seite 17
Standard parts from item no. 100 - see page 17

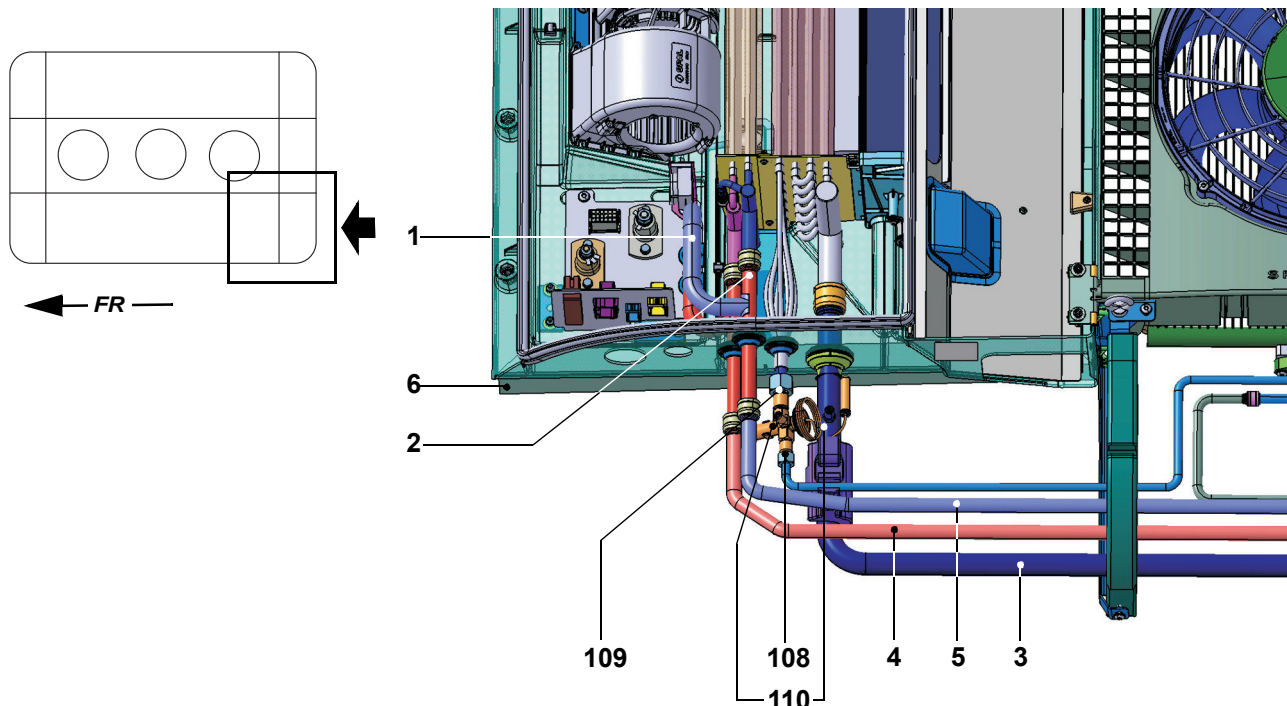

Hinweis: Abgebildet ist die REVO 360. / Note: REVO 360 is shown.

Pos./ Item	Stück/Quantity REVO							Bestell-Nr./ Part. no.	Benennung	Description	Bemerkung/Remarks
	280	360	400	360 NBG	HV	Art Master	Art Slave				
6	2	2		2	2	2	2	11115822B	Schaumstoffrahmen	rubber foam frame	
8 no fig.	1	1	1	1	1	1	1	11116288A	Klebeband	adhesive tape	für Armaflexrahmen/ for Armaflex frame
9 no fig.	4	4	4	4	4	4	4	11114970A	Kondenswasser- stutzen	condensate stud	
10 no fig.	1	1			1			88394B	Steuerung, Stellmotor	control device, actuator motor	
11 no fig.				1		1	1	11122733A	Stellmotor	actuator motor	

Normteile ab Pos. 100 siehe Seite 17
Standard parts from item no. 100 - see page 17

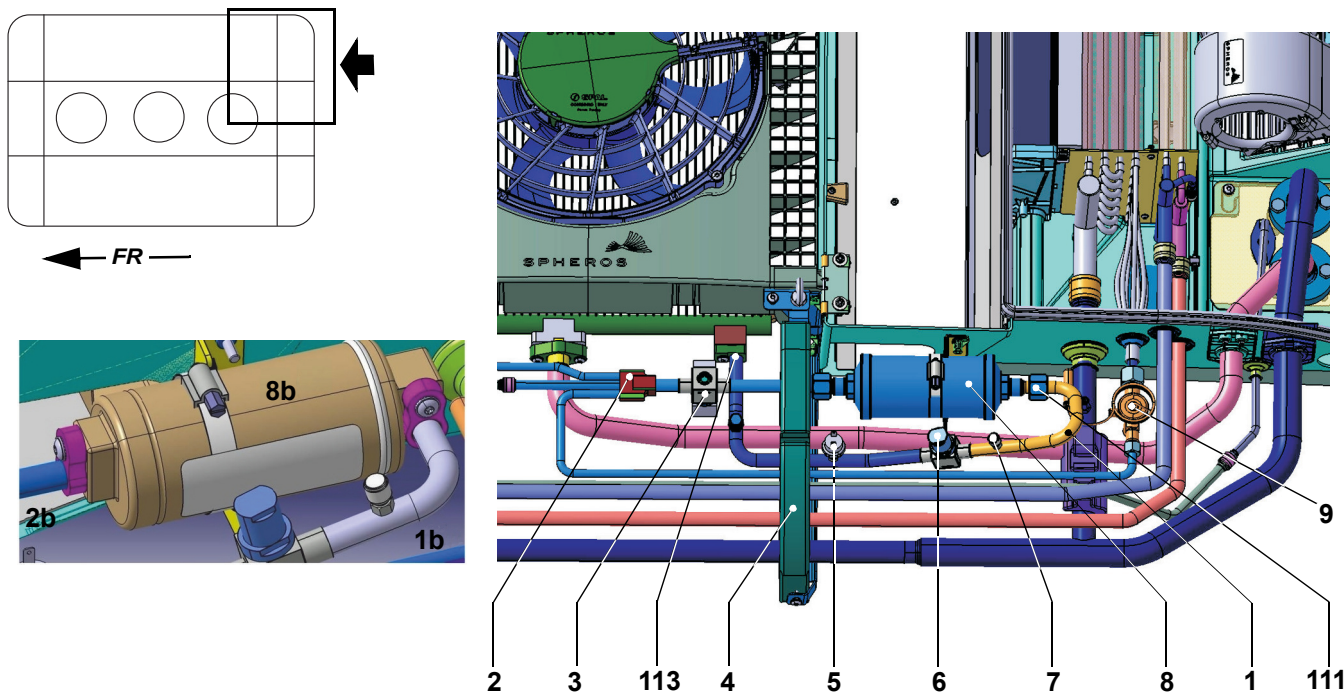

Hinweis: Abgebildet ist die REVO 360. / Note: REVO 360 is shown.

Pos./ Item	Stück/Quantity REVO							Bestell-Nr./ Part. no.	Benennung	Description	Bemerkung/Remarks
	280	360	400	360 NBG	HV	Art Master	Art Slave				
Verrohrung / piping											
1a	1	1						1xxxxxxA	Leitung, Verflüssiger-Trockner	line, condenser-drier	bis / until 03/2016 inkl. O-Ringe Pos. / incl. o-rings items 111, 113
1b	1	1		1		1		11121673A	Leitung, Verflüssiger-Trockner SMA	line, condenser-drier SMA	ab / from 2016
1c	1	1						1112xxxxA	Leitung, Verflüssiger-Trockner	line, condenser-drier	ab / from 04/2016 inkl. O-Ringe Pos. / incl. o-rings items 111, 113
2a	1	1	1	1				11125994A	Flüssigkeitsleitung	liquid line	Service Info
2b	1	1	1					11121674A	Flüssigkeitsleitung SMA Anschluss	liquid line SMA connection	ab / from 2016
2c	1	1	1	1				11125994A	Flüssigkeitsleitung SMA Anschluss	liquid line SMA connection	ab / from 2019
2d						1		11144860A	Flüssigkeitsleitung SMA mit Bypass	liquid line SMA with bypass	
3	1	1	1	1		1		1103673A	Einsatz, Magnetventil	insert, solenoid valve	
3	1	1	1	1		1		1102620A	Spule, Magnetventil	coil, solenoid valve	
4	2	2	2	2	2	2	2	11115012C	Rohrhalterung	clamp, pipe	
5	1	1	1	1		1		11114982C	Druckschalter	pressure switch	
6	1	1	1	1		1		1103672C	Absperrventil	shut-off valve	
7a	1	1	1	1		1		1100951A	Überdruckventil	over pressure switch	
7b	1	1	1	1				11125858A	Überdruckventil	over pressure switch	ab / from 05/2018 O-Ring mitbest., Pos. 114 / or- der also o-ring, item 114
8a	1	1	1					11117544A	Filtertrockner-Kit	filter drier kit	inkl. 2 O-Ringe, Pos. 111 /incl. 2 o-rings, item 111
8b	1	1	1	1		1		11123222A	Filtertrockner-Kit	filter drier kit	ab / from 2016 inkl. 2 O-Ringe, Pos. 112 /incl. 2 o-rings, item 112
9	1	1	1	2		1	2	11119611B	Expansionsventil	expansion valve	

Normteile ab Pos. 100 siehe Seite 17
Standard parts from item no. 100 - see page 17

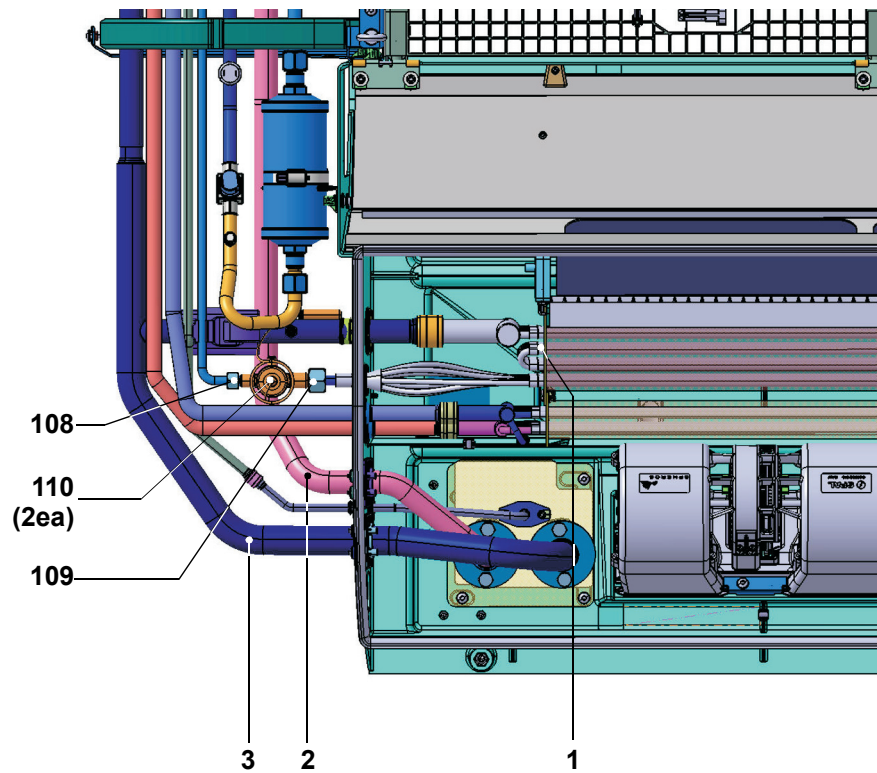
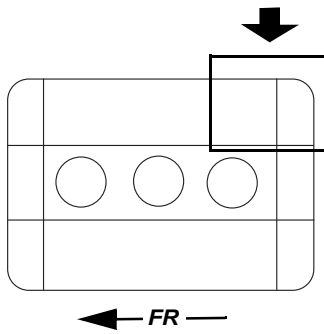

Hinweis: Abgebildet ist die REVO 360. / Note: REVO 360 is shown.

Pos./ Item	Stück/Quantity REVO							Bestell-Nr./ Part. no.	Benennung	Description	Bemerkung/Remarks
	280	360	400	360 NBG	HV	Art Master	Art Slave				
Verrohrung / piping											
1	1	1	1	1		1	1	31738B	Thermostat, Vereisungsschutz	thermostat, icing protection	
2	1	1	1					11115807B	Druckleitung	pressure line	
2				1		1		11117487B	Druckleitung LH	pressure line LH	
3	1	1	1					11115808C	Saugleitung	suction line	
3				1		1		11117488B	Saugleitung LH	suction line LH	

Normteile ab Pos. 100 siehe Seite 17
Standard parts from item no. 100 - see page 17

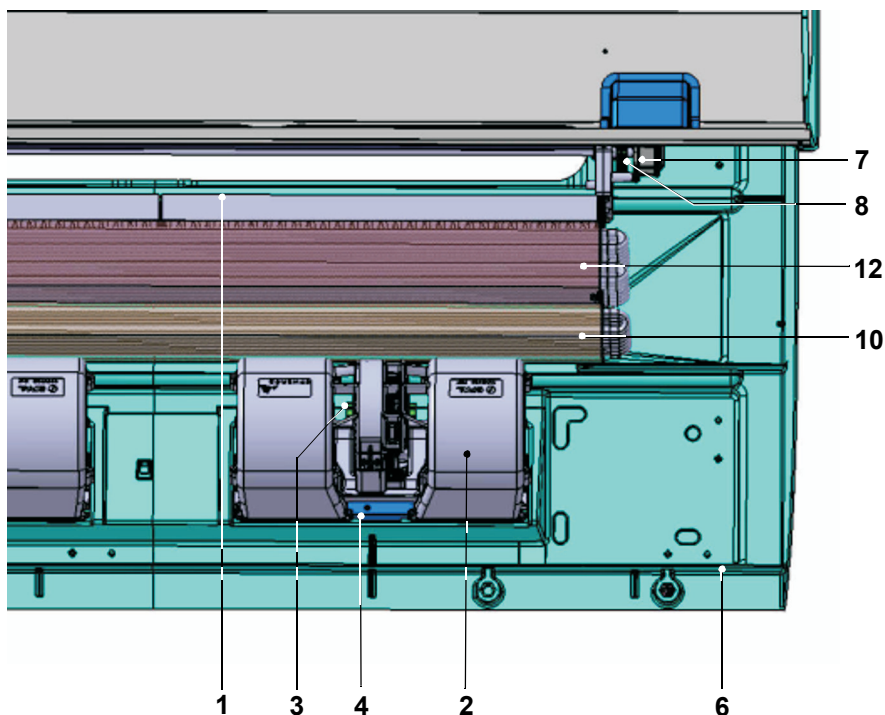
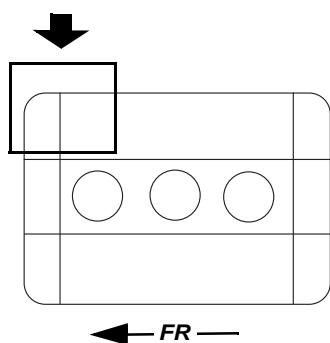

Hinweis: Abgebildet ist die REVO 360. / Note: REVO 360 is shown.

Pos./ Item	Stück/Quantity REVO							Bestell-Nr./ Part. no.	Benennung	Description	Bemerkung/Remarks
	280	360	400	360 NBG	HV	Art Master	Art Slave				
Heizteil / Verdampfer / heating element / evaporator											
1	6	6	8	6	6	6	6	11114854C	Luftfilter	air filter	Einzelfilter / single filter
1 no fig.	1	1	1	1	1	1	1	11117394A	Luftfilter-Kit REVO	air filter kit REVO	6 Stk. im Karton / 6 ea per box
2	4	4			6			11122715A	Gebläse, Doppelradial	fan, double radial	ersetzt / replaces 11114118C
2				6		6	6	11120703B	Gebläse, Doppelradial	fan, double radial	
3	12	12	16	12	12	12	12	11115298B	Klammer, Gebläse, hinten	clamp, fan, rear	
4	6	6	8	6	6	6	6	11115299A	Klemmleiste, Gebläse	terminal row, fan	
5 no fig.	2	2	2	2	2	2	2	11115617B	Haubenstange	cover support rod	
6	5 m	5 m	6 m	5 m	5 m	5m	5m	11115639A	Dichtprofil (pro Haube)	sealing profile (per cover)	in Meter/in meters
7	2	2	2		2			1104166C	Stellmotor	actuator motor	
7				1		2	2	11122733A	Stellmotor	actuator motor	
8	2	2	2	2	2	2	2	1102050B	Klappendämpfer	flap damper	

Normteile ab Pos. 100 siehe Seite 17
Standard parts from item no. 100 - see page 17

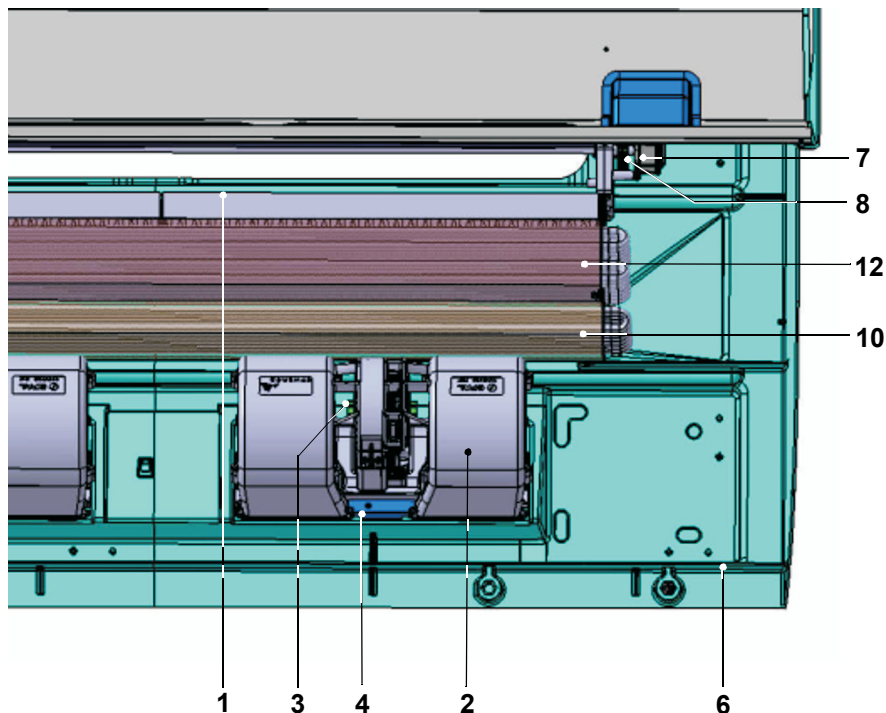
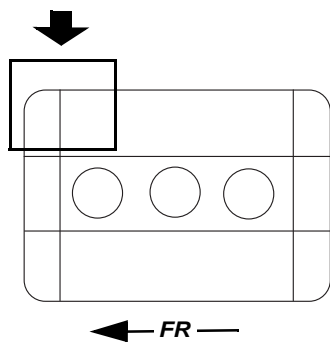

Hinweis: Abgebildet ist die REVO 360. / Note: REVO 360 is shown.

Pos./ Item	Stück/Quantity REVO							Bestell-Nr./ Part. no.	Benennung	Description	Bemerkung/Remarks
	280	360	400	360 NBG	HV	Art Master	Art Slave				
10a			1					11114383C	Heizteil, rechts	heating element, RH	
10b					1	1	1	11114311D	Heizteil, rechts	heating element, RH	
10c no fig.					1	1	1	11114352D	Heizteil, links	heating element, LH	
11a no fig.	1	1		1				11116902A	Verdampfer, links	evaporator, LH	Service Info
11b no fig.						1	1	11114349E	Verdampfer, links	evaporator, LH	
12a	1	1		1				11116903A	Verdampfer, rechts	evaporator, RH	
12b						1	1	11114350E	Verdampfer, rechts	evaporator, RH	

Normteile ab Pos. 100 siehe Seite 17
Standard parts from item no. 100 - see page 17

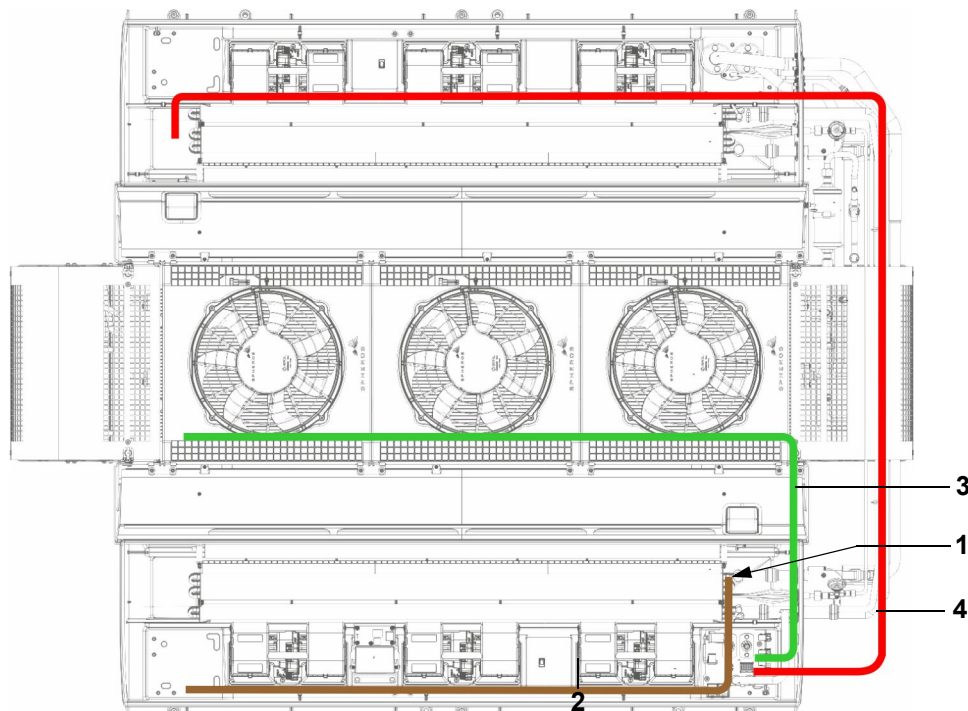

Hinweis: Abgebildet ist die REVO 360. / Note: REVO 360 is shown.



Pos./ Item	Stück/Quantity REVO							Bestell-Nr./ Part. no.	Benennung	Description	Bemerkung/Remarks
	280	360	400	360 NBG	HV	Art Master	Art Slave				

Elektrik / electrics

1	1	1	1		1			1103377A	Thermostat, Vereisungsschutz	thermostat, icing protection	
1				1		1		31738B	Thermostat, Vereisungsschutz	thermostat, icing protection	
2	1	1			1			11115805C	Kabelbaum, Verdampfer, links inkl. Grundplatte	wiring harness, evaporator, LH incl. base plate	inkl. Grundplatte / incl. base plate
2			1					11126096A	Kabelbaum, Verdampfer, links inkl. Grundplatte	wiring harness, evaporator, LH incl. base plate	
3	1	1						11115806B	Kabelbaum, Verflüssiger	wiring harness, condenser	
3			1					11120753A	Kabelbaum, Verflüssiger	wiring harness, condenser	
4					1			11115804B	Kabelbaum, Verdampfer, rechts	wiring harness, evaporator, RH	
4			1					11120646C	Kabelbaum, Verdampfer, rechts	wiring harness, evaporator, RH	
5 no fig.				1		1		11141338A	Kabelbaum, Verdampfer, RH	wiring harness, evaporator, RH	
6 no fig.				1		1		11141337A	Kabelbaum, Verdampfer, LH	wiring harness, evaporator, LH	
7 no fig.				1				11121198A	Kabelbaum, Verflüssiger	wiring harness, condenser	

Pos./Item	Stück/Quantity REVO							Bestell-Nr./Part. no.	Benennung	Description	Bemerkung/Remarks
	280	360	400	360 NBG	HV	Art Master	Art Slave				
100								11115529B	Schraube, Typ DS WN5451, 60x22	screw, type DS WN5451, 60x22	
101								11115527A	Schraube, Typ DS WN5451, 40x16	screw, type DS WN5451, 40x16	
102								11115526A	Schraube, Typ DS WN5451, 40x12	screw, type DS WN5451, 40x12	
103								11115509A	Clipmutter, 60x2,0x11	clip nut, 60x2.0x11	in Verbindung mit Pos. 100 / together with item 100
104								11115508A	Clipmutter, 40x2,5x9	clip nut, 40x2.5x9	Verbindung Verdampfer/Heizteil / connection evaporator/heating element
105								11115563A	Schraube Torx, M6x25	screw Torx head, M6x25	
106								11115683C	Schraube M8x25 TX40 VA ISO14583	screw M8x25 TX40 VA ISO14583	
107								11115684B	Scheibe, 8.4x25x1.5 VA DIN522	washer, 8.4x25x1.5 VA DIN522	wird zus. mit Pos. 106 verbaut / installed together with item 106
108								80812A	O-Ring, 7.65 x 1.78, R134A-beständig	O-Ring, 7.65 x 1.78, R134A-resistant	zw. Expansionsventil u. Flüssigkeitsleitg. / btw. expansion valve a. liquid line
109								80640A	O-Ring, 10.6 x 1.78, R134A-beständig	O-Ring, 10.6 x 1.78, R134A-resistant	zw. Expansionsventil u. Rohr vom WT / btw. expansion valve a. pipe from heat exchanger
110								1103522B	O-Ring, 4.48 x 1.78, R134A-beständig	O-Ring, 4.48 x 1.78, R134A-resistant	zw. Expansionsventil u. Ausgleichsleitg. 2x / btw. expansion valve a. compensation line, 2 times
111								80641A	O-Ring, 14 x 1.78, R134A-beständig	O-Ring, 14 x 1.78, R134A-resistant	drier
112								11117038A	O-Ring, 11 x 2.5, R134A-beständig	O-Ring, 11 x 2.5, R134A-resistant	zw. Rohrgruppe u. Sammler / btw. pipe groups a. receiver
113								69052A	O-Ring, 26 x 2, R134A-beständig	O-Ring, 26 x 2, R134A-resistant	zw. Verflüssigeransch. u. Leitg. Verfl.-Trockner / btw. condenser a. condenser - drier line
114								11125860A	O-Ring, 8.55 x 1.75, R134A-beständig	O-Ring, 8.55 x 1.75, R134A-resistant	Überdruckventil ab / from 05/2018
115 - 117											
118 no fig.								11121596A	Haubenschrauben REVO 8x M8x25	cover screws REVO 8ea M8x25	Kit, enthält Pos. 106 u. 107 / kit, contains item 106 and 107
119 no fig.								11117080A	Spheros Service-Koffer (LOKRING)	Spheros service case (LOKRING)	
120 no fig.								11116888A	LOKRING Kupplung, Ø 12	LOKRING coupling, Ø 12	
121 no fig.								11117849A	LOKRING Kupplung, Ø 16	LOKRING coupling, Ø 16	
122 no fig.								11116889A	LOKRING Kupplung, Ø 18	LOKRING coupling, Ø 18	
123 no fig.								11116890A	LOKRING Kupplung, Ø 28	LOKRING coupling, Ø 28	
124 no fig.								11115842A	LOKPREP 65G	LOKPREP 65G	Dichtmittel / sealing material, 15 ml

Stückzahl nach Bedarf / Quantity as required

