



PARTS & SERVICE

Klimaanlage
Air conditioning system

Ersatzteil-Liste
Spare parts list

REVO GLOBAL 250
TemSA SKODA

Inhalt/Content:

Übersicht / Overview	Bild/fig. 1
Komponenten Systemsteuerung / system control components	Bild/fig. 2
Haube / Cover	Bild/fig. 3
Verflüssiger, Axialgebläse / condenser, axial fan	Bild/fig. 4
Kältemittelsammler / refrigerant receiver	Bild/fig. 5
Komponenten / components	Bild/fig. 6
Komponenten / components	Bild/fig. 7
Heizteil, Verdampfer / heating element, evaporator	Bild/fig. 8
Klappenantrieb, Luftfilter / flap actuator, air filter	Bild/fig. 9
Kabelbäume / wiring harnesses	Bild/fig. 10
Normteile, Halbzeuge / standard parts, semi-finished parts	Seite/page 1
Montage Teile / Montage Parts	Bild/fig. 11
Frontbox Montage Teile / Frontbox Montage Parts	Bild/fig. 12
Verdichter Gruppe / Compressor Group	Bild/fig. 13

**Notwendige Angaben zur schnellen Ersatzteilermittlung: /
Required data for quick spare part identification:**

- Klimaanlage/typ: z.B. REVO GLOBAL /
- A/C unit model: e.g. REVO GLOBAL
- Spheros-Identnummer: z.B. 11116166A
- Spheros ID: e.g. 11116166A
- Produktionsdatum: z.B. 20141024/
- Date of production: e.g. 20141024
- Seriennr: z.B. 14182756/
- Serial no.: e.g. 14182756

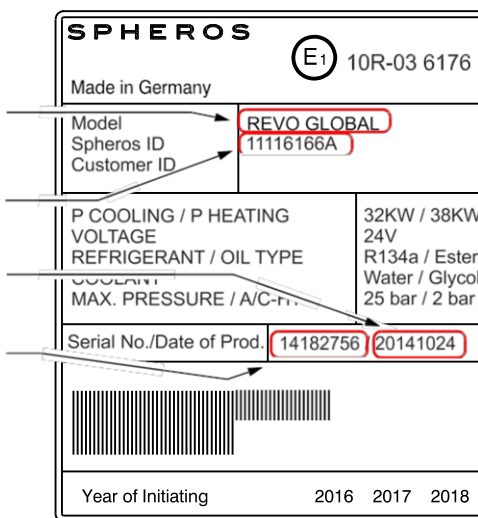

Hinweis: Nach rechts eingerückte Teile bzw. Untergruppen (durch Punkte markiert) sind in den um einen Punkt weniger eingerückten Baugruppen enthalten.

Note: Sub-assemblies or components (marked by a point) - offset to the right - are contained in the assembly which is offset one point less.

Änderungen vorbehalten. Die aktuelle Fassung dieser Ersatzteilliste steht unter <http://www.valeo-thermalbus.com/tr> zum Download bereit. /
Subject to modification. Latest version of this spare parts list is provided for download on <http://www.valeo-thermalbus.com/tr>

REVO Global Varianten / REVO Global Variants

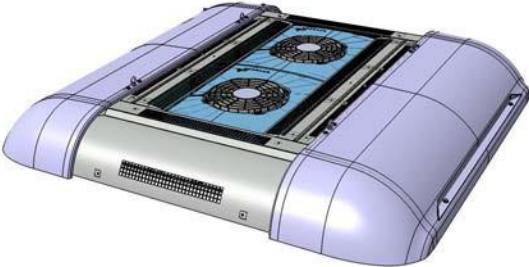

REVO Global 200



REVO Global 250

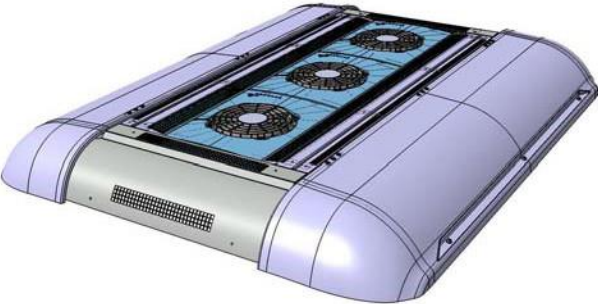

REVO Global 350



REVO Global 400

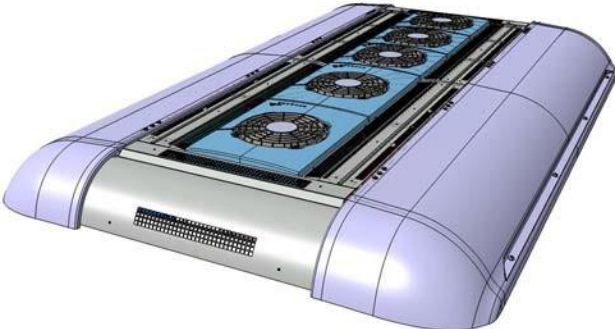

REVO Global 450

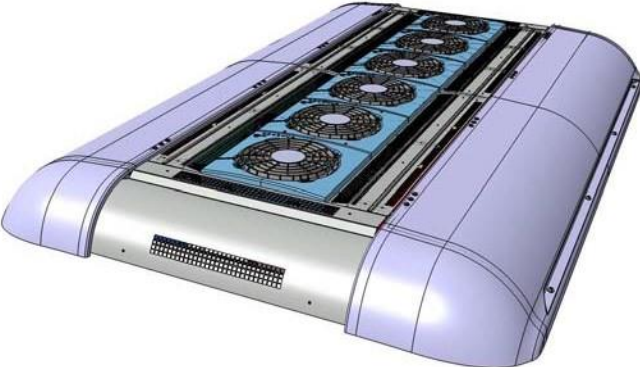

REVO Global 500

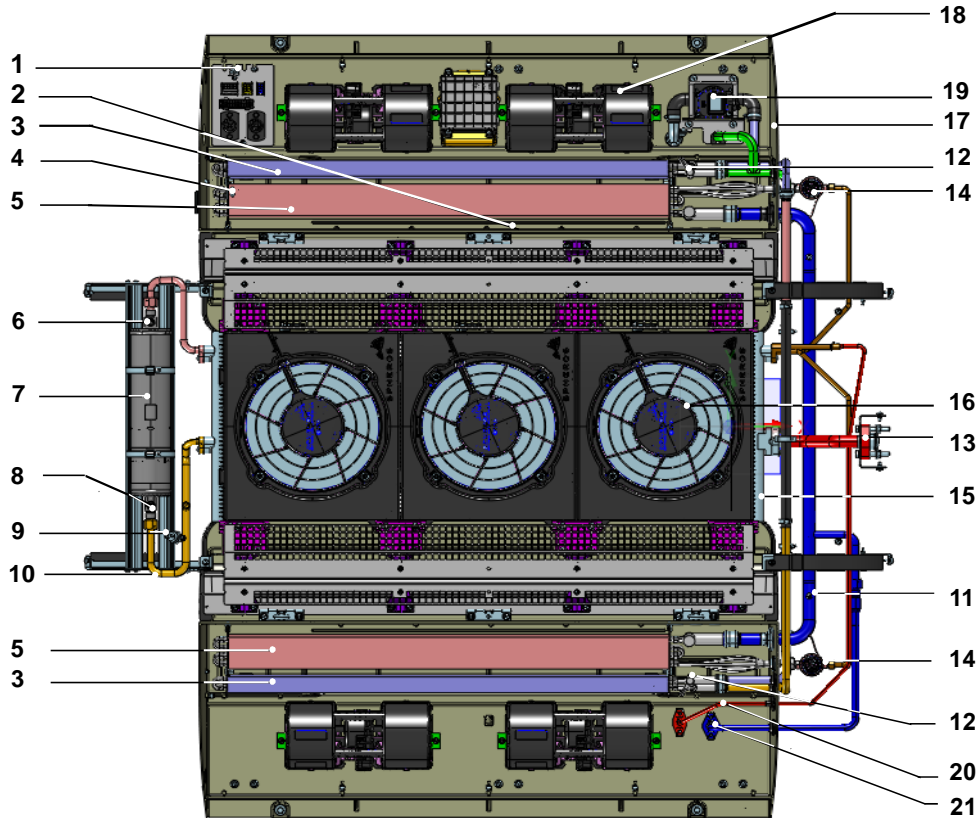

- 1 Elektrik-Schnittstelle
- 2 Temperatursensor
- 3 Heizteil
- 4 Eissensor zw. 1. und 2. Rohrreihe
- 5 Verdampfer
- 6 Schauglas
- 7 Sammler-Trockner
- 8 Kältemittel-Füllventil
- 9 Druckschalter
- 10 Absperrventil
- 11 Saugleitung
- 12 Entlüftung, Heizteil
- 13 Druckleitung
- 14 Expansionsventil
- 15 Verflüssiger
- 16 Axiallüfter, Verflüssiger
- 17 Position Typschild
- 18 Radialgebläse
- 19 Wasserventil
- 20 Fronboxleitung
- 21 Frontboxleitung Sauganschluss

- 1 electrical interface
- 2 temperature sensor
- 3 heat exchanger
- 4 ice sensor betw. 1st and 2nd pipe row
- 5 evaporator
- 6 sight glass
- 7 collector-dryer
- 8 refrigerant charging valve
- 9 pressure switch
- 10 shut-off valve
- 11 suction pipe
- 12 air bleed, heater
- 13 pressure pipe
- 14 expansion valve
- 15 condenser
- 16 axial fan, condenser
- 17 position of type plate
- 18 radial fan
- 19 water valve
- 20 frontbox pipe
- 21 frontbox pipe connection suction

Normteile ab Pos. 100 siehe Seite 15
 Standard parts from item no. 100 - see page 15

REVO Global - Bild 2/fig. 2

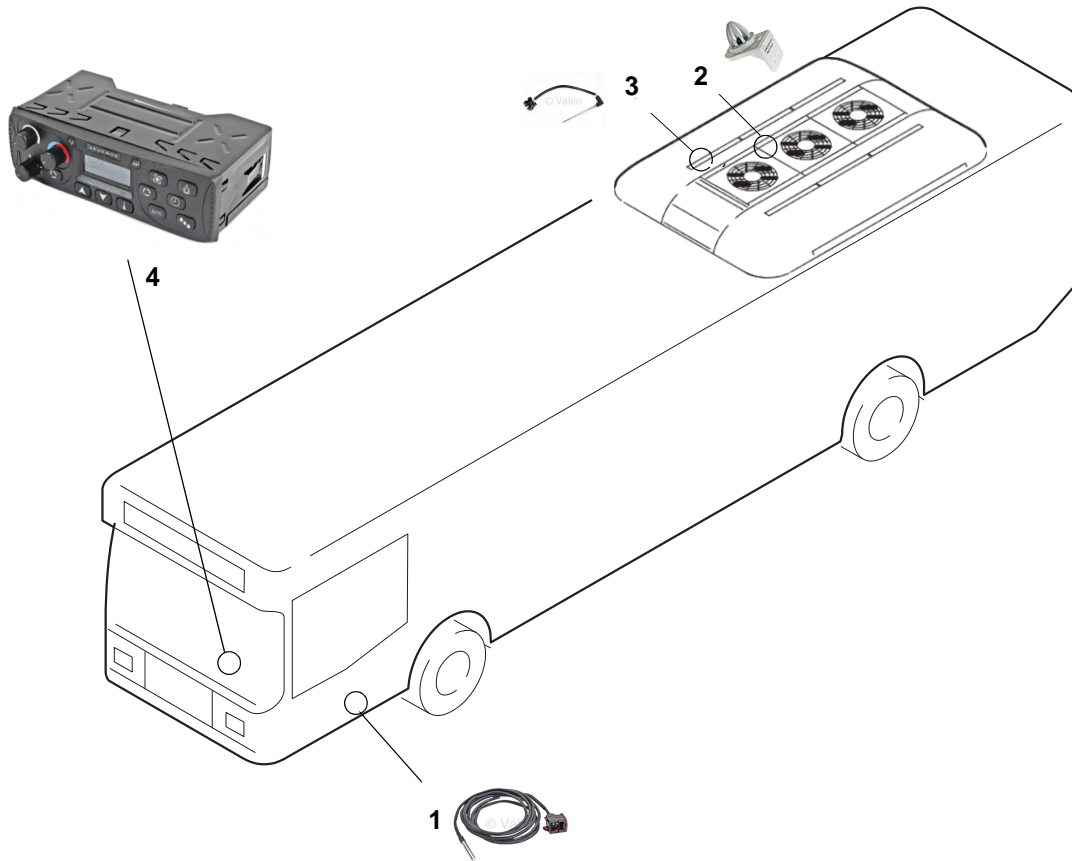

Pos./Item	Stück/Quantity			Bestell-Nr./Part. no.	Benennung	Description	Bemerkung/Remarks
	REVO Global 250						
		with heating	only cooling				

Komponenten Systemsteuerung / system control components

1			1		11117015A	Temperaturfühler, aussen	temperature sensor, outside	
2			1		11117017A	Temperaturfühler, Raum	temperature sensor, room	
3			1		83186A	Temperaturfühler, Eis	temperature sensor, ice	
4			1		11144084A	Bedienteil SC1000	control panel SC1000	(TemSA / Skoda Parameter)

Normteile ab Pos. 100 siehe Seite 15
 Standard parts from item no. 100 - see page 15

REVO Global - Bild 3/fig. 3

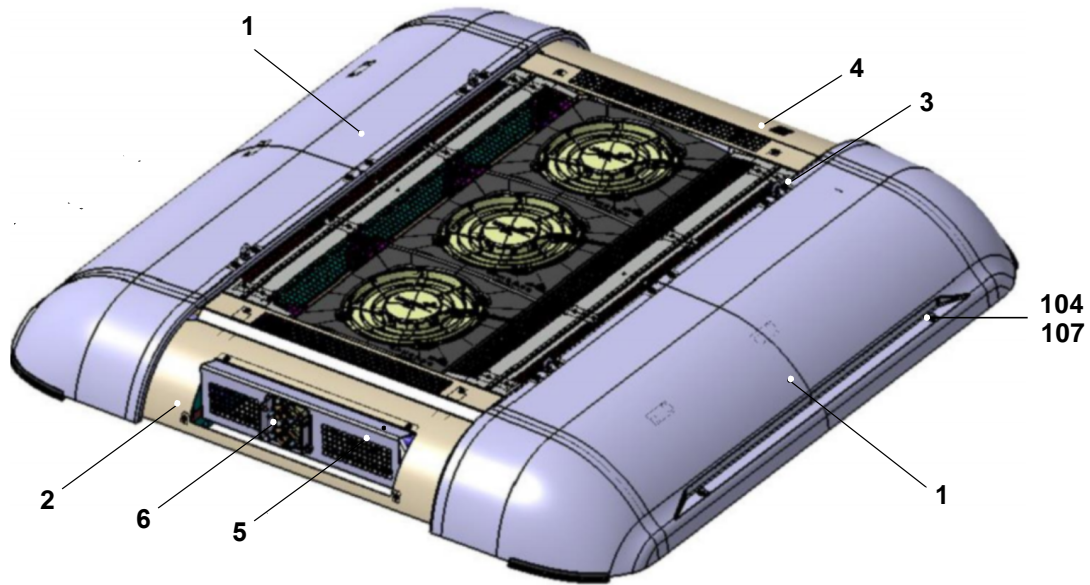

Pos./ Item	Stück/Quantity REVO Global 250				Bestell-Nr./ Part. no.	Benennung	Description	Bemerkung/Remarks
	with heating	only cooling						

Haube / cover

1		2			11119672C	Haube, re/li	cover, RH/LH	RG 250
2		1			11119560C	Haube, hi/vo	cover, rear/front	
3		6			11119562B	Haubenscharnier	hinge, cover	
4		1			11123780A	Abdeckung RG-m	COVER RG-m	
5		1			11123768B	Halter KM-Rohre RG mittig	Support RF-Pipes RG Central	
6		1			11123859B	Adapterblech KM-Rohre	RF-Support Adapter	
7 no fig.		2			11119609E	Dämmmatte, Haube 1360x518x10	insulating mat, cover 1360x518x10	RG 250

Normteile ab Pos. 100 siehe Seite 15
 Standard parts from item no. 100 - see page 15

REVO Global - Bild 4/fig. 4

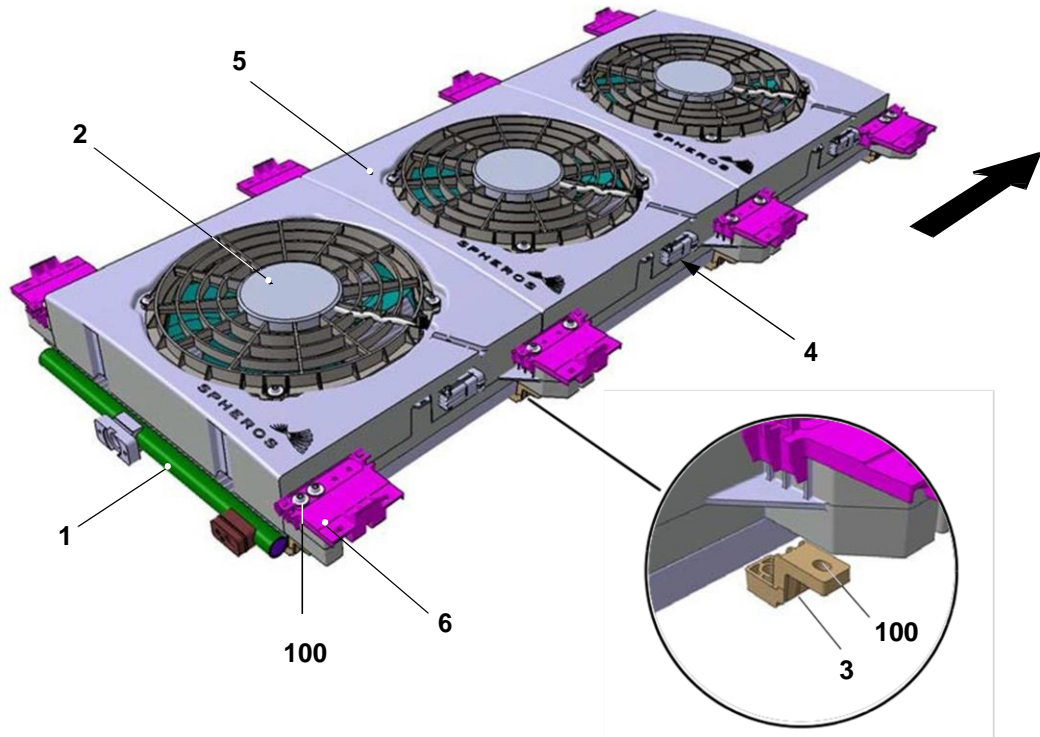

Pos./Item	Stück/Quantity REVO Global 250				Bestell-Nr./Part. no.	Benennung	Description	Bemerkung/Remarks
	with heating	only cooling						

Verflüssiger, Axialgebläse / condenser, axial fan

1		1			11122550A	Verflüssiger, 1300	Condenser, 1300	
2		3			11122717C	Axialgebläse	axial fan	
3		12			11114857C	Klammer, Verflüssiger	clamp, condenser	
4		1			11119221C	Kabelbaum	wiring harness	RG 250
5		3			11118778E	Axialgebläsemodul 400	axial fan module 400	
6		8			11118716B	Halterung	attachment bracket	RG 200 - 400

Normteile ab Pos. 100 siehe Seite 15
 Standard parts from item no. 100 - see page 15

REVO Global - Bild 5/fig. 5

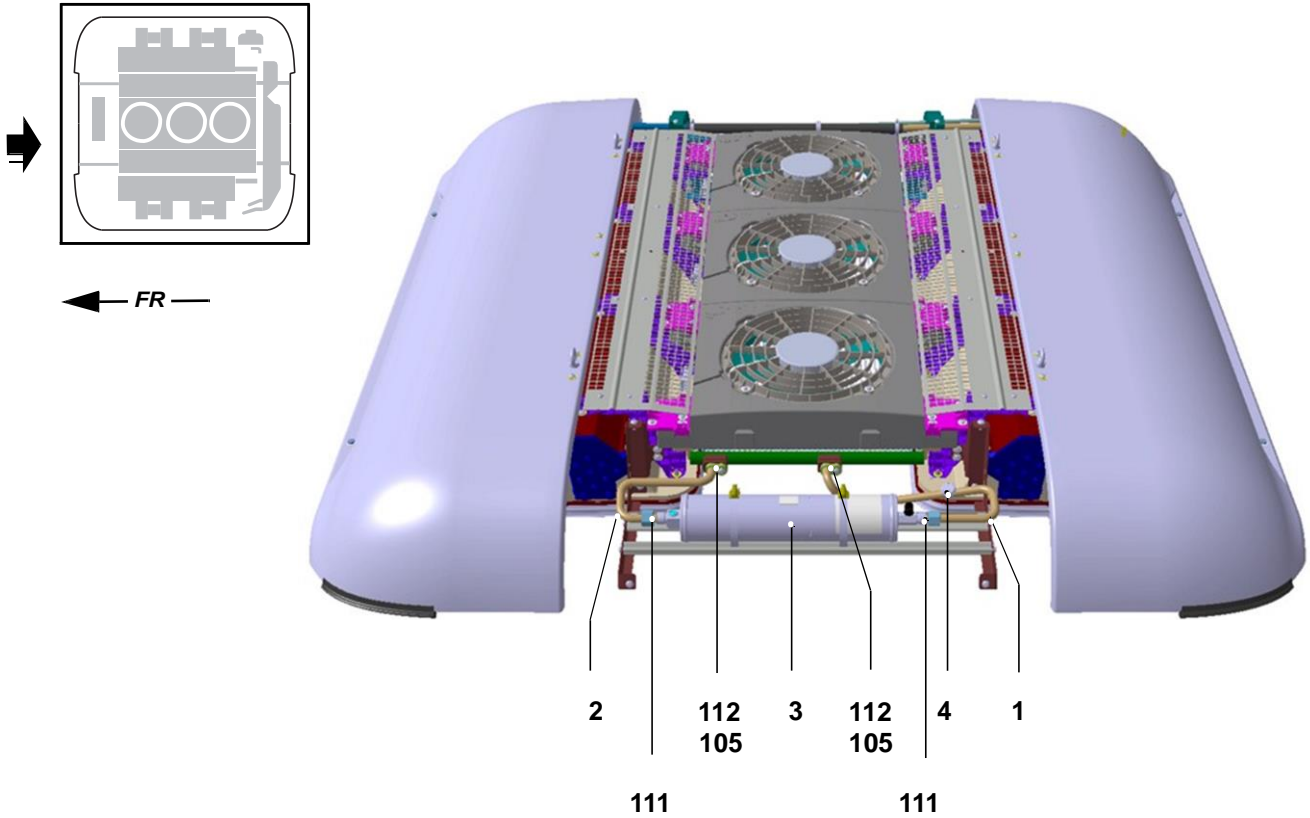

Pos./Item	Stück/Quantity REVO Global 250				Bestell-Nr./ Part. no.	Benennung	Description	Bemerkung/Remarks
	with heating	only cooling						

Kältemittelsammler / refrigerant receiver

1		1			11118997C	Leitung, Verflüssiger - Sammler	line, condenser - receiver	
2		1			11118998B	Leitung, Sammler - Unterkühler	line, receiver-super cooler	
3		1			11123774A	Kältemittelsammler	refrigerant receiver	
4		1			11114982C	Druckschalter	pressure switch	

Normteile ab Pos. 100 siehe Seite 15
 Standard parts from item no. 100 - see page 15

REVO Global - Bild 6/fig. 6

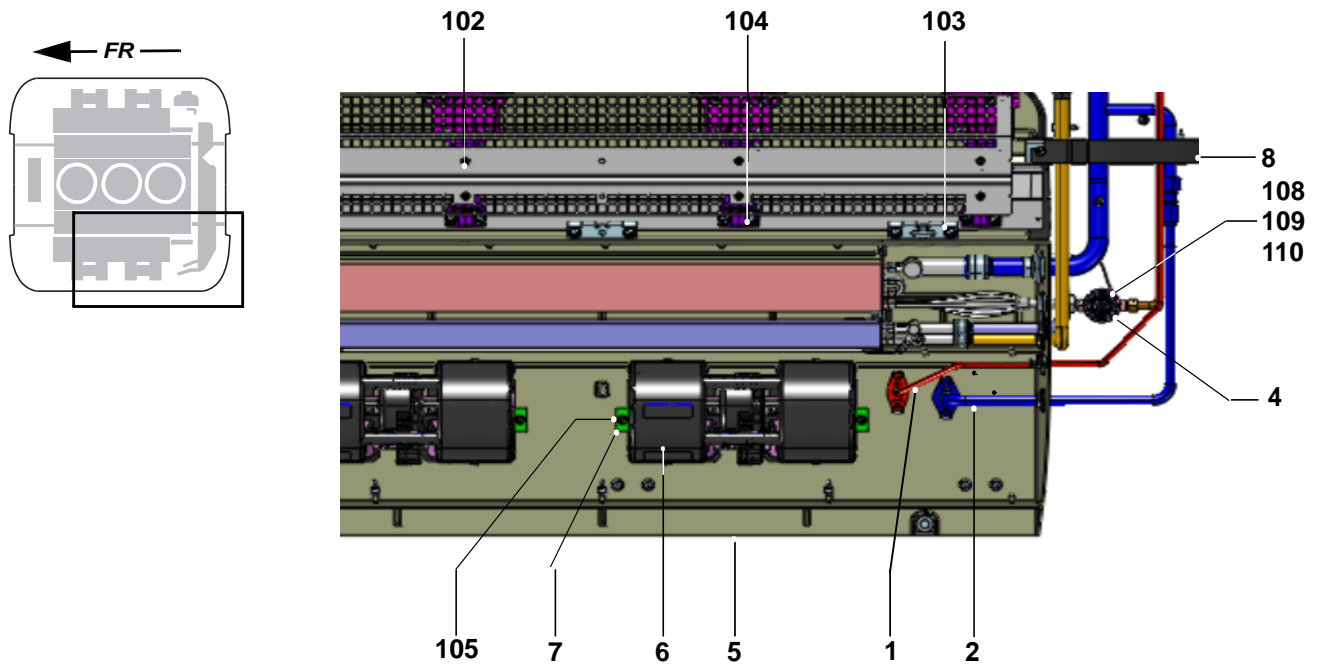

Pos./ Item	Stück/Quantity REVO Global 250				Bestell-Nr./ Part. no.	Benennung	Description	Bemerkung/Remarks
	with heating	only cooling						
Komponenten / components								
1		1			11119017B	Fronboxleitung 1, links	frontbox line 1, left	Siehe auch Serviceinformation „Reparaturanweisung REVO“, Spheros Service-Koffer (LOKRING) (Pos. 119) notwendig / See also service information “REVO Repair instruction”, Spheros service case (LOKRING) (item 119) required
2		1			11123781A	Frontboxleitung Sauganschluss	frontbox pipe connection suction	
3								
4		2			11119611B	Expansionsventil	expansion valve	
5		2			11119953A	Dichtprofil, Dach	sealing profile, roof	
6		4			11120703B	Gebläse, Doppelradial	fan, double radial	
7		8			1102026C	Klammer, Gebläse	clamp, fan	
8		2			11119483A	Halterung, Rohr	support, pipe	
9 no fig.		4			11114970A	Stutzen, Kondenswasser	stud, condensation	

Normteile ab Pos. 100 siehe Seite 15
 Standard parts from item no. 100 - see page 15

REVO Global - Bild 7/fig. 7

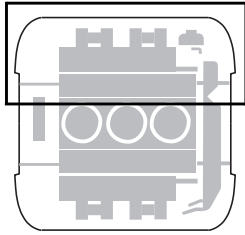

← FR →

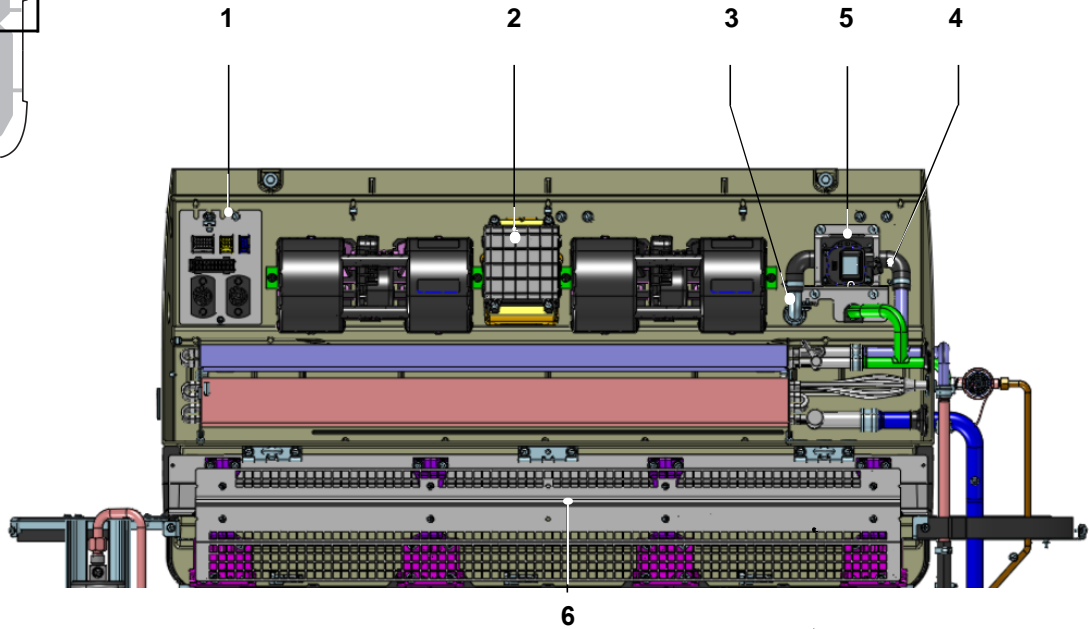

Pos./ Item	Stück/Quantity REVO Global 250				Bestell-Nr./ Part. no.	Benennung	Description	Bemerkung/Remarks
		with heating	only cooling					

Komponenten / components

1		1			11143968A	Kabelbaum	wiring harness	
2		1			11144060A	Unterstation SU020	Substation SU020	
3		1			11119018B	Wasserrohr, D22	water pipe, D22	
4		1			11119622A	Formschlauch 90°, D22	water hose, elbow, D22	
5		1			11119561B	Wasserventil	water valve	
6		2			11119590D	Laubgitter	leaf guard	RG 250

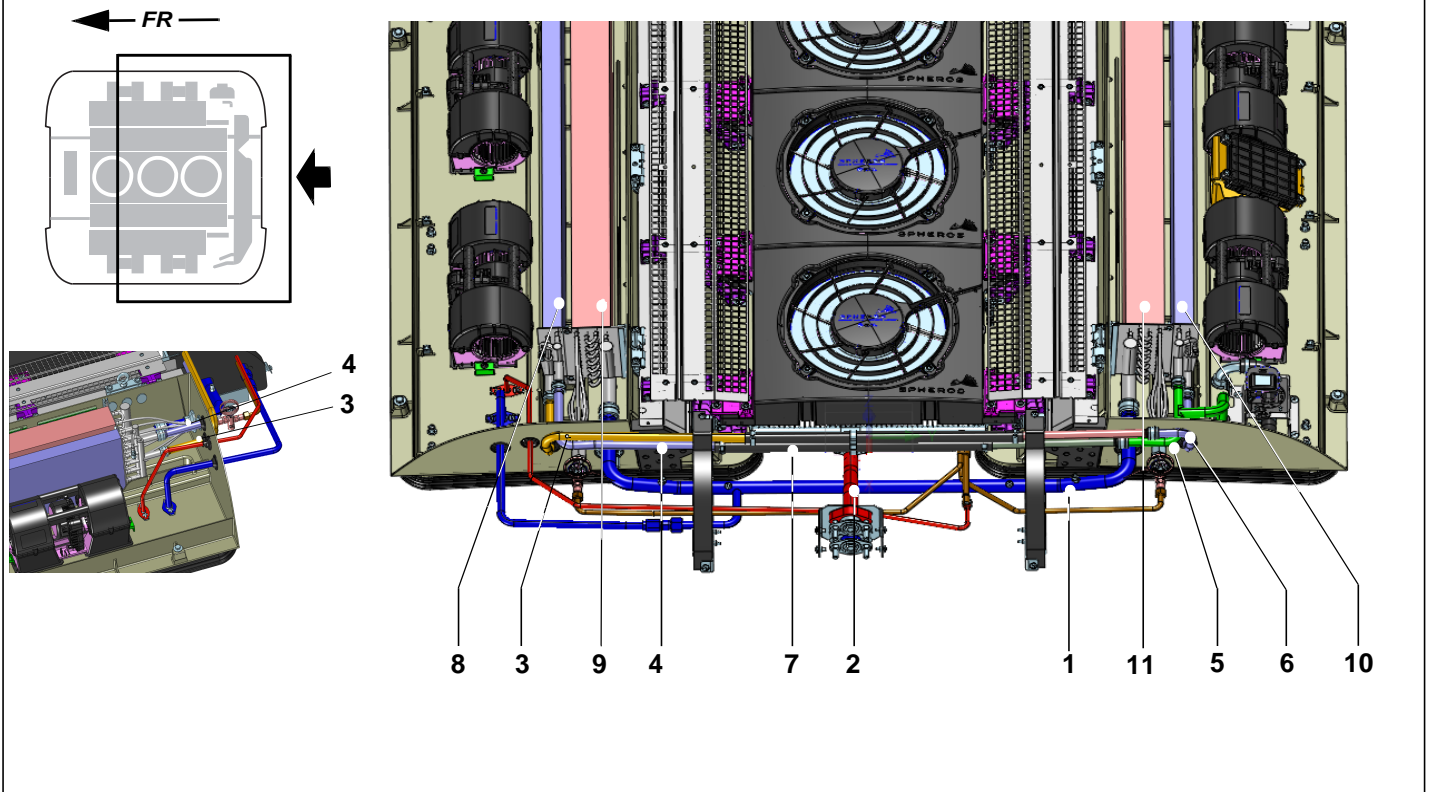

Pos./Item	Stück/Quantity REVO Global 250		Bestell-Nr./ Part. no.	Benennung	Description	Bemerkung/Remarks
	with heating	only cooling				

Heizteil, Verdampfer / heating element, evaporator

1		1		11123779A	Saugleitung, zentral	suction line, centrally
2		1		11123778B	Druckleitung, zentral	pressure line, centrally
3		1		11119032B	Wasserleitung, Rücklauf, re	water line, return, RH
4		1		11119072B	Wasserleitung, Vorlauf, re	water line, flow, RH
5		1		11119019B	Wasserleitung, Rücklauf, re	water line, return, RH
6		1		11119020B	Wasserleitung, Vorlauf, re	water line, flow, RH
7		2		11119987A	Wasserschlauch, D18	water hose, D18
8		1		11118737A	Wärmetauscher, li, 1000	heat exchanger, LH, 1000
9		1		11118733A	Verdampfer, li, 1000	evaporator, LH, 1000
10		1		11118738A	Wärmetauscher, re, 1000	heat exchanger, RH, 1000
11		1		11118734A	Verdampfer, re, 1000	evaporator, RH, 1000

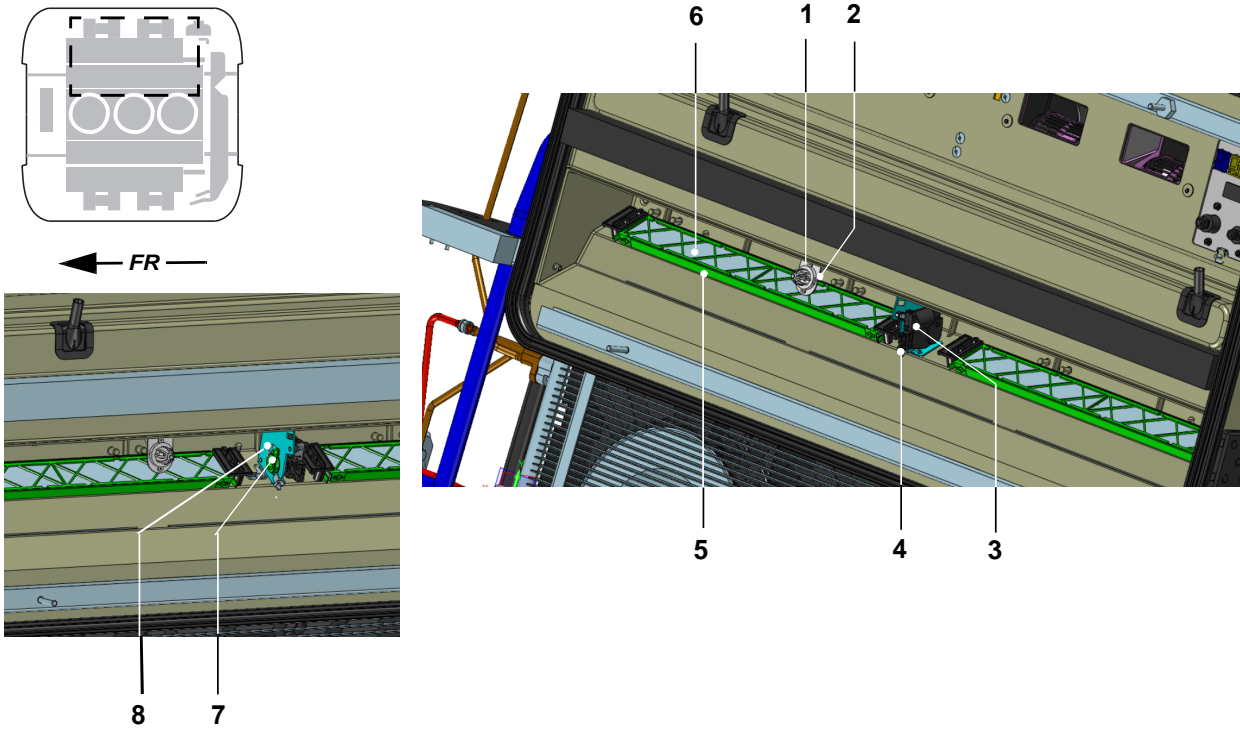

Pos./Item	Stück/Quantity REVO Global 250				Bestell-Nr./ Part. no.	Benennung	Description	Bemerkung/Remarks
	with heating	only cooling						

Klappenantrieb, Luftfilter / flap actuator, air filter

1		1			11117017A	Temperatursensor	temperature sensor	
2		1			11121378A	Anschlussadapter, Temperatursensor	wiring adapter, temperature sensor	
3		2			11120134A	Klappenantrieb, Frischluft	flap actuator, fresh air	
4		2			11121986B	Anschlussadapter, Klappenantrieb	wiring adapter, flap actuator	
5		4			11118718B	Gehäuse, Luftfilter	cartridge, air filter	
6		4			11119607A	Luftfilter	air filter	
7		2			11121514A	Exzenter Klappeneinheit	Excenter Flap Unit	
8		2			11121531A	Stange	rod	

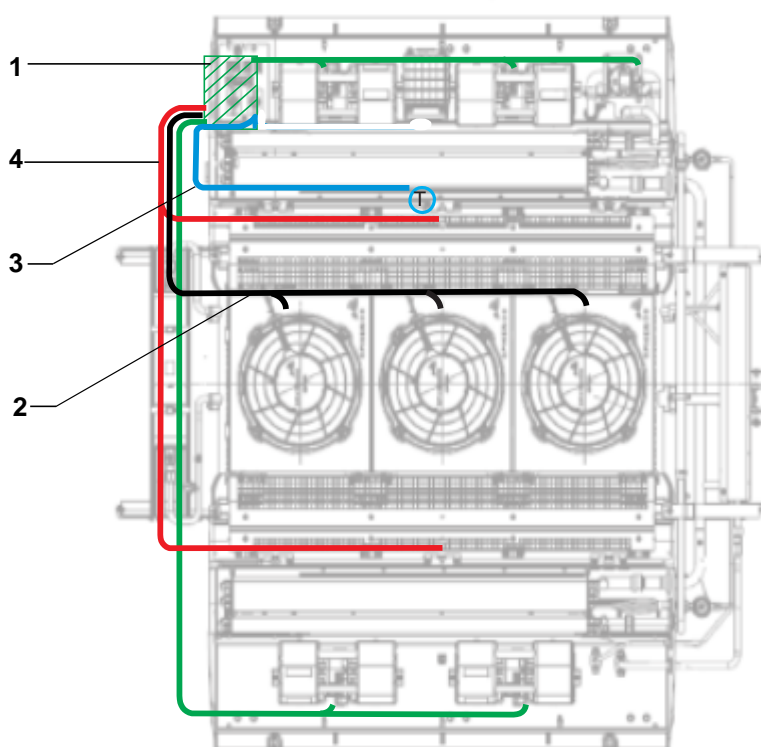







Pos./Item	Stück/Quantity REVO Global 250				Bestell-Nr./Part. no.	Benennung	Description	Bemerkung/Remarks
		with heating	only cooling					

Kabelbäume / wiring harnesses

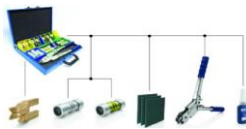
1		1			11143968A	Kabelbaum, Lüfter	wiring harness, fans	mit Anschlussplatte/ with terminal plate RG 250
2		1			11119221C	Kabelbaum, Verflüssiger	wiring harness, condenser	RG 250
3		1			11121378A	Kabelbaum, Sensoren	wiring harness, sensors	
4		2			11121986B	Kabelbaum, Frischluft	wiring harness, fresh air	

Pos./Item	Stück/Quantity REVO Global 250					Bestell-Nr./ Part. no.	Benennung	Description	Bemerkung/Remarks
			with heating	only cooling					

Normteile, Halbzeuge / Standard parts, semi-finished parts

100			x			11115529B	Schraube, Typ DS WN5451, 60x22	screw, type DS WN5451, 60x22	
101			x			11115527A	Schraube, Typ DS WN5451, 40x16	screw, type DS WN5451, 40x16	
102			x			11119729A	Schraube, Typ DS WN5451, 50x16	screw, type DS WN5451, 50x16	
103			x			11118281A	Schraube Torx M6x16	screw Torx head, M6x16	in Verbindung mit Pos. 100 / together with item 100
104			x			11120368A	Schraube Torx M6x20	screw Torx head, M6x20	Verbindung Verdampfer/ Heizteil / connection evapo- rator/heating element
105			x			11115563A	Schraube Torx, M6x25	screw Torx head, M6x25	
106			x			11119731A	Schraube, Hauben, M8x25	screw, cover, M8x25	
107			x			11115684B	Scheibe, VA	washer, VA, 8.4x20x1.5	wird zus. mit Pos. 106 ver- baut / installed together with item 106
108			x			80812A	O-Ring, 7.65 x 1.78, R134A-beständig	O-Ring, 7.65 x 1.78, R134A-resistant	zw. Expansionsventil u. Flüssigkeitsleitg. / btw. ex- pansion valve a. liquid line
109			x			80640A	O-Ring, 10.6 x 1.78, R134A-beständig	O-Ring, 10.6 x 1.78, R134A-resistant	zw. Expansionsventil u. Rohr vom WT / btw. expan- sion valve a. pipe from heat exchanger
110			x			1103522B	O-Ring, 4.48 x 1.78, R134A-beständig	O-Ring, 4.48 x 1.78, R134A-resistant	zw. Expansionsventil u. Ausgleichsleitg. 2x / btw. expansion valve a. com- pensation line, 2 times
111			x			80641A	O-Ring, 14 x 1.78, R134A-beständig	O-Ring, 14 x 1.78, R134A-resistant	Sammler/receiver
112			x			11117038A	O-Ring, 11 x 2.5, R134A-beständig	O-Ring, 11 x 2.5, R134A-resistant	zw. Rohrgruppe u. Sammler / btw. pipe groups a. receiver
113			x			69052A	O-Ring, 26 x 2, R134A-beständig	O-Ring, 26 x 2, R134A-resistant	zw. Verflüssigeranschl. u. Leitg. Verfl.-Trockner / btw. condenser a. condenser - drier line
119 no fig.			x			11117080A	Spheros Service-Koffer (LOKRING)	Spheros service case (LOKRING)	
120 no fig.			x			11116888A	LOKRING Kupplung, Ø 12	LOKRING coupling, Ø 12	
121 no fig.			x			11117849A	LOKRING Kupplung, Ø 16	LOKRING coupling, Ø 16	
122 no fig.			x			11116889A	LOKRING Kupplung, Ø 18	LOKRING coupling, Ø 18	
123 no fig.			x			11116890A	LOKRING Kupplung, Ø 28	LOKRING coupling, Ø 28	
124 no fig.			x			11115842A	LOKPREP 65G	LOKPREP 65G	Dichtmittel / sealing material, 15 ml 

Stückzahl nach Bedarf / Quantity as required

REVO Global - Bild 11/fig. 11



MontageTeile / Montage Parts

Pos./ Item	Stück/Quantity REVO Global 250				Bestell-Nr./ Part. no.	Benennung	Description	Bemerkung/Remarks
		with heating	only cooling					
1		1			11144084A	Bedienteil SC1000	Control Unit SC1000	(TemSA/Skoda Parameter)
2		1			11117015A	Ausstemperatursensor	outside temperature sensor	
3		1			11118005A	Temperaturfühler	temperature sensor	
4		16			8402249B	Wasserschlauch DN16x3	water hose DN16x3	
5		1			80812A	O-Ring 7,65x1,78	O-Ring 7,65x1,78	
6		2			80641A	O-Ring 14,0x1,78	O-Ring 14,0x1,78	
7		1			24632A	Flanschdichtung rund	flange sealing round	
2		1			22939A	Kork-Isolierband Presstite	cork-isolation Presstite	
9		2			1100802A	Flanschanschluß 90°NW20	Flange Connection 90°NW20	female
10		1			1100834A	Flanschanschluß 90°NW25	Flange Connection 90°NW25	female
11		1			25660A	Flanschanschluß 180°NW25	Flange Connection 180°NW25	male
12		0,90			81934A	Kältemittelschlauch NW20	refrigerant hose NW20	
13		0,60			81935A	Kältemittelschlauch NW25	refrigerant hose NW25	
14		0,60			81552A	Armaflexschlauch 9x42	Armaflex tube 9x42	
15		0,90			1100950A	Armaflexschlauch D35x6	Armaflex tube D35x6	
No Fig.		1			11144082A	Kältemittelschlauch Set NW25	Refrigerant hose Kit NW25	
No Fig.		1			11144083A	Kältemittelschlauch Set NW20	Refrigerant hose Kit NW20	

REVO Global - Bild 12/fig. 12



MontageTeile / Montage Parts

Pos./ Item	Stück/Quantity REVO Global 250				Bestell-Nr./ Part. no.	Benennung	Description	Bemerkung/Remarks
		with heating	only cooling					
1		2			11112460A	Schraubanschluss NW16 90° O-Ring	o-ring fitting 90° NW16	
2		1			11114524A	Schraubanschluss NW13 90° O-Ring	o-ring fitting 90° NW13	
3		1			11115953A	Schraubanschluss NW10 90° O-Ring	o-ring fitting 90° NW10	
4		2			11118005A	Temperaturfühler	temperature sensor	
5		1			80812A	O-Ring 7,65x1,78	O-Ring 7,65x1,78	
6		2			80641A	O-Ring 14,0x1,78	O-Ring 14,0x1,78	
7		1			80640A	O-Ring 10,6/10,82x1,78	O-Ring 10,6/10,82x1,78	
2		1			22939A	Kork-Isolierband Presstite	cork-isolation Presstite	
9		6			83792A	Kältemittelschlauch NW16	refrigerant hose NW16	
10		6			11138136A	Kältemittelschlauch NW12	refrigerant hose NW12	
11		6			25317A	Armaflexschlauch 28x6	Armaflex tube 28x6	
No Fig.		1			11144085A	Kältemittelschlauch Set NW16	Refrigerant hose Kit NW16	
No Fig.		1			11144086A	Kältemittelschlauch Set NW12	Refrigerant hose Kit NW12	

REVO Global - Bild 13/fig. 13

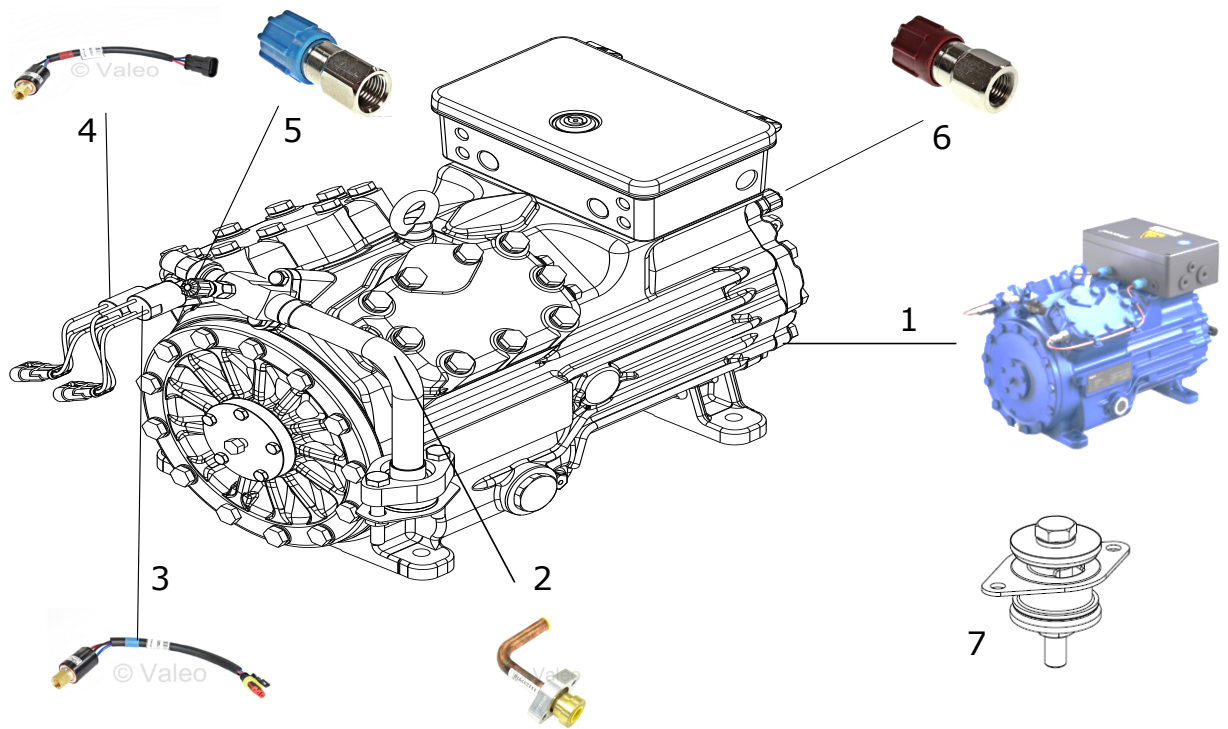

Verdichter Gruppe / Compressor Group

Pos./ Item	Stück/Quantity REVO Global 250				Bestell-Nr./ Part. no.	Benennung	Description	Bemerkung/Remarks
		with heating	only cooling					
1		2			11123791A	Verdichter HGX34E 380-4 A	compressor HGX34E / 380-4 A	
2		1			11123797B	Adapter Druckleitung	adapter pressure pipe	
3		1			11114278B	Niederdruckschalter	low-pressure switch	
4		1			11114279B	Hochdruckschalter	high-pressure switch	
5		1			11117030A	Service Anschluss Niederdruck gerade	service connection low pressure straight	
6		1			11117031A	Hochdruck-Serviceanschluss gerade	high pressure connection straight	
7		1			11123792A	Schwingmetallpuffer	anti-vibration metal buffer	

