



**HEATING SYSTEMS**

# **THERMO PLUS 160/230/300/350**

**Installation instructions**

Rev. 03/2021  
Id.No. 11121149C





Improper installation or repair of Valeo heating and cooling systems can cause fire or the leakage of deadly carbon monoxide leading to serious injury or death.

To install and repair Valeo heating and cooling systems you need to have completed a Valeo training course and have the appropriate technical documentation, special tools and special equipment.

**NEVER** try to install or repair Valeo heating or cooling systems if you have not completed a Valeo training course, you do not have the necessary technical skills and you do not have the technical documentation, tools and equipment available to ensure that you can complete the installation and repair work properly.

**ALWAYS** carefully follow Valeo installation and repair instructions and heed all **WARNINGS**.

Valeo rejects any liability for problems and damage caused by the system being installed by untrained personnel.

Highlighted words like Warning!, Caution!, ATTENTION and NOTE in these Installation instructions signify the following precautions:



## **Warning!**

This caption is used to indicate possible severe injuries or fatal accidents if instructions or procedures are carried out incorrectly or entirely disregarded.



## **Caution!**

This caption is used to indicate possible minor injuries if instructions or procedures are carried out incorrectly or entirely disregarded.

## **ATTENTION:**

This caption points to actions which may cause material damage.

## **NOTE:**

This caption is used to draw attention to an important feature.

**NOTE:** Subject to modification. In multilingual versions the German language is binding. The latest version of this document is provided for download on [www.valeo-thermalbus.com](http://www.valeo-thermalbus.com).



## Table of content

1	Statutory regulations governing installation	1
2	Use / version	3
3	Installation	5
4	Installation example	9
5	Installation of the circulating pump	10
6	Connection to the vehicle cooling system	11
7	Fuel supply	12
8	Combustion air supply	14
9	Exhaust pipe	15
10	Electrical connections	16
11	Initial start-up	22
12	Maintenance	23
13	Malfunctions	24
14	Technical data	26
15	Environment	29
Annex		A-1
	Circulating pumps installation position	A-1

## 1 Statutory regulations governing installation

### 1.1. Statutory regulations governing installation

For the heaters exist type approvals according to the ECE Regulations

R10 (EMC):	No. 05 7559 and
R122 (Heater)	No. 00 0580 for Thermo plus 130
	No. 00 0466 for Thermo plus 230
	No. 00 0467 for Thermo plus 300
	No. 00 0468 for Thermo plus 350

Installation is governed above all by the provisions in Annex 7 of the ECE Regulation R122.

#### NOTE:

The provisions of these Regulations are binding within the territory governed by ECE Regulations and should similarly be observed in countries without specific regulations.

#### Extract from ECE Regulation R122, Annex 7:

“ ...

4. *The heater must have a manufacturer's label showing the manufacturer's name, the model number and type together with its rated output in kilowatts. The fuel type must also be stated and, where relevant, the operating voltage and gas pressure.*

(...)

7.1. *A clearly visible tell-tale in the operator's field of view shall inform when the combustion heater is switched on or off.*

... “

#### Extract from ECE Regulation R122, Part I:

“ ...

### 5.3 Vehicle Installation Requirements for Combustion Heaters

#### 5.3.1 Scope

5.3.1.1 *Subject to paragraph 5.3.1.2., combustion heaters shall be installed according to the requirements of paragraph 5.3.*

5.3.1.2 *Vehicles of category O having liquid fuel heaters are deemed to comply with the requirements of paragraph 5.3.*

#### 5.3.2 Positioning of combustion heater

5.3.2.1 *Body sections and any other components in the vicinity of the heater must be protected from excessive heat and the possibility of fuel or oil contamination.*

5.3.2.2 *The combustion heater shall not constitute a risk of fire, even in the case of overheating. This requirement shall be deemed to be met if the installation ensures an adequate distance to all parts and suitable ventilation, by the use of fire resistant materials or by the use of heat shields.*

5.3.2.3 *In the case of M2 and M3 vehicles, the combustion heater must not be positioned in the passenger compartment. However, an installation in an effectively sealed envelope which also complies with the conditions in paragraph 5.3.2.2. may be used.*

5.3.2.4 *The label referred to in Annex 7, paragraph 1.4., or a duplicate, must be positioned so that it can be easily read when the heater is installed in the vehicle.*

5.3.2.5 *Every reasonable precaution should be taken in positioning the heater to minimize the risk of injury and damage to personal property.*

### 5.3.3 Fuel supply

5.3.3.1 *The fuel filler must not be situated in the passenger compartment and must be provided with an effective cap to prevent fuel spillage.*

5.3.3.2 *In the case of liquid fuel heaters, where a supply separate from that of the vehicle is provided, the type of fuel and its filler point must be clearly labelled.*

5.3.3.3 *A notice, indicating that the heater must be shut down before refuelling, must be affixed to the fuelling point. In addition a suitable instruction must be included in the manufacturer's operating manual.*

### 5.3.4 Exhaust system

5.3.4.1 *The exhaust outlet must be located so as to prevent emissions from entering the vehicle through ventilators, heated air inlets or opening windows.*

### 5.3.5 Combustion air inlet

5.3.5.1 *The air for the combustion chamber of the heater must not be drawn from the passenger compartment of the vehicle.*

5.3.5.2 *The air inlet must be so positioned or guarded that blocking by rubbish or luggage is unlikely.*

(...)

### 5.3.8 Automatic control of the heating system

5.3.8.1 *The heating system must be switched off automatically and the supply of fuel must be stopped within five seconds when the vehicle's engine stops running. If a manual device is already activated, the heating system can stay in operation.*

... „

### ATTENTION:

Failure to follow the installation instructions and the notes contained therein will lead to all liability being refused by Valeo. The same applies if repairs are carried out incorrectly or with the use of parts other than genuine spare parts. This will result in the invalidation of the type approval for the heater and therefore of its ECE Type Approval.



At petrol stations and other fuel filling facilities the heater must be switched off due to the explosion hazard. To advice to this requirement the self-adhesive label with the text "Switch off heater before refueling!", delivered with each heater, is to be affixed next to the filler neck.

## 2 Use / version

### 2.1. Use of the water heaters

The water heaters, hereafter referred to as heaters, are used in conjunction with the vehicle's own heating system

- to heat the passenger cabin, and
- for pre-heating.

The heater may only be installed and operated in vehicles of the class **M2, M3, N2, N3, O1, O2, O3, O4**.

Any use beyond is not permitted.

The heaters operate independently of the engine and are connected to the cooling system, the fuel system and the electrical system of the vehicle.



The heater is not approved for use in vehicles carrying dangerous goods according to Annex 9 of the UN/ECE Regulation R122.



The heater must not be operated:

- at filling stations and other refueling points.
- if the heater or its exhaust outlet is in locations where inflammable vapors or dust may form (e.g. close to fuel, plastic, coal, wood dust or cereal storage facilities or similar).
- if the heater or its exhaust outlet is located close to inflammable materials for example dry grass and leaves, cartons, paper etc.
- in enclosed areas (e.g. garages, hall without extraction system), not even if the pre-selection timer or Tele Start is used.
- if the exhaust outlet of the heater is partial or fully obstructed (e.g. by soil or snow, as it may occur while move the vehicle backwards).

The heater must:

- be shut down and the fuse shall be removed in the event of extensive smoke development, unusual combustion noises or fuel odors. The heater must not be used again until personnel trained by Valeo have examined it.

## 2.2. Versions

### **Thermo plus 160 – 24V**

Water heater for „diesel“  
with 16 kW (13800 kcal/h) heat current

### **Thermo plus 230 – 24V**

Water heater for „diesel“  
with 23 kW (20000 kcal/h) heat current

### **Thermo plus 300 – 24V**

Water heater for „diesel“  
with 30 kW (26000 kcal/h) heat current

### **Thermo plus 350 – 24V**

Water heater for „diesel“  
with 35 kW (30000 kcal/h) heat current

## 2.3. Use / Function

See Workshop Manual!



### 3 Installation

#### ATTENTION:

- **The statutory regulations governing the installation must be adhered.**
- **If the water heater is to be operated in a separately installed heating system, prior to installation an installation planning report must always be submitted to Valeo for approval. If this approval is not obtained, all warranty and liability claims will be void. The water heater has been designed, tested and approved for specific bus requirements.**
- **To the temperature sensor cable no mechanical load must be applied (pull on the cable, carry the heater at the cable etc.).**
- **Heaters and circulating pumps shall be always installed in such a way that a negative impact by road dirt, splashing water, exhaust gases or other harmful influences is excluded.**

#### NOTE:

Consider the installation situation of the relevant vehicle type.

#### 3.1. Installation location

The heater and the circulating pump are to be integrated into the cooling system (or in a separate heating system). The requirements regarding the combustion air supply (see Chapter 8) must be considered.

The heater should be installed as low as possible to allow the heater and circulating pump to be bled automatically. This is particularly important as the circulating pump is not self-priming.

If it is not possible to install the heater in the vehicle's engine bay it may be installed in a box. The installation box must have a sufficient external ventilation to ensure that the maximum temperature of 100°C is not exceeded in the box.

This installation space is not a stowage compartment and must be kept clear. This prohibition applies in particular for fuel canisters, oil cans, fire

extinguishers, cleaning rags, paper and all easily flammable materials.

Water which has been ingressed or condensed must be able to run autonomously from the installation space.

Bear in mind the space required for servicing accessibility (for example for removing the combustion chamber) (see Figures 1 and 5) when installing the heater.

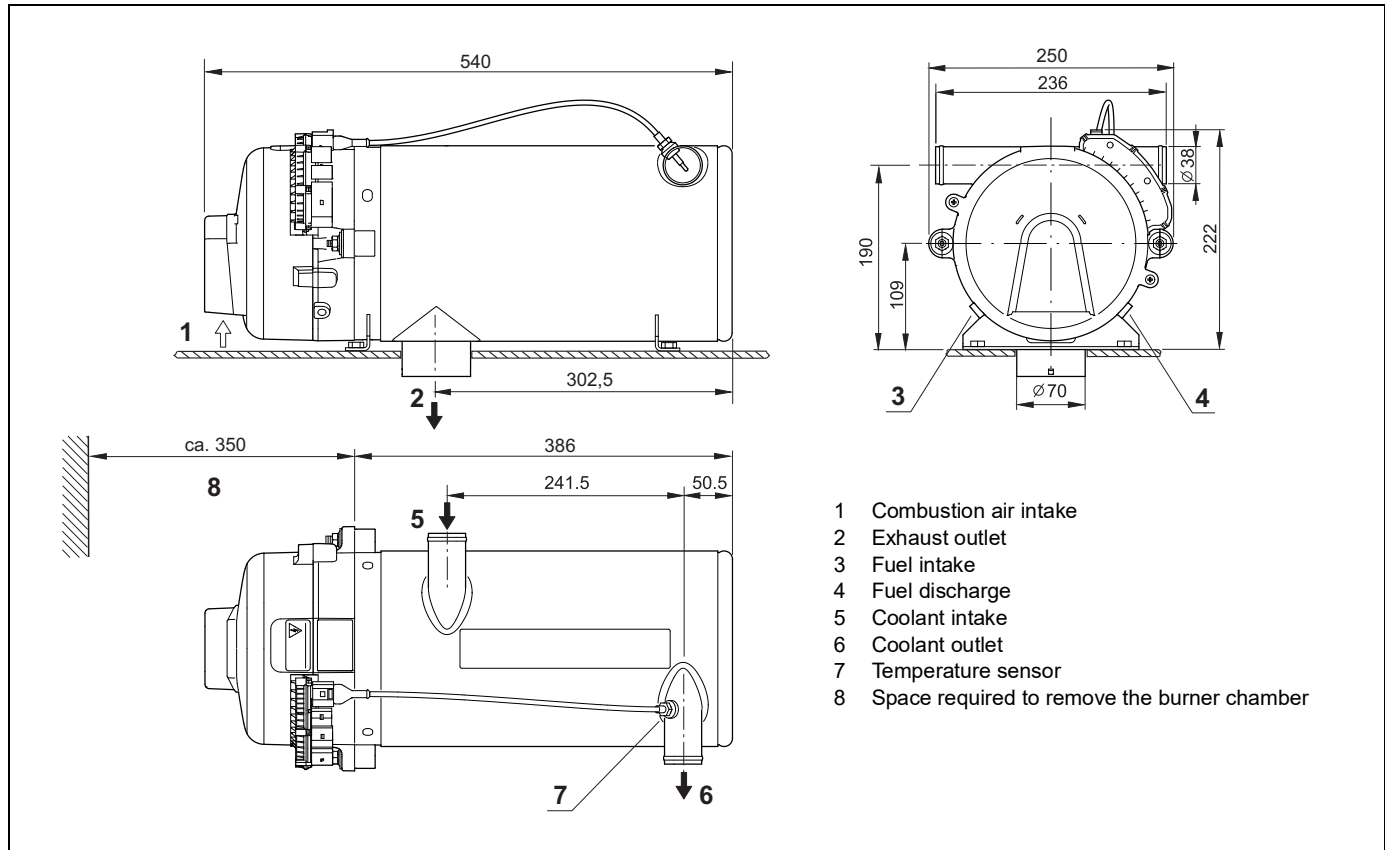

Fig. 1: Dimensions of the Thermo plus 230/300/350 heater (horizontal installation)

### 3.2. Installation of a Thermo plus heater

**NOTE:**

The heaters are only licensed for horizontal installation (see Fig. 2).

The heater may be secured either with four M8 screws or with four screws and nuts (see Figure 3) .

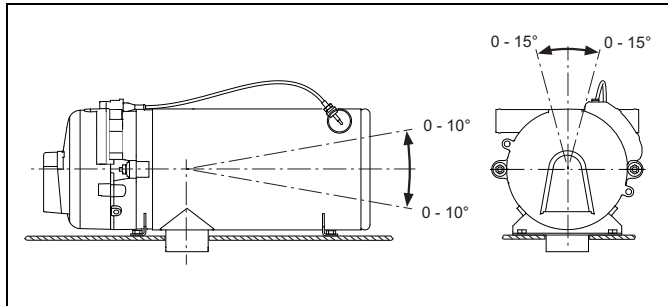

**Fig. 2: Installation position**

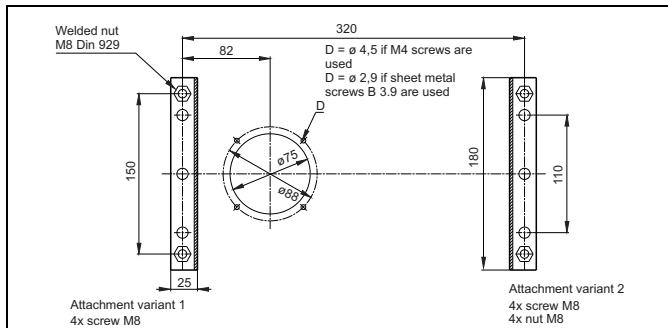

**Fig. 3: Hole pattern**

### 3.3. Model plate

The model plate must be protected from damage and must be clearly legible when the heater is installed (otherwise a duplicate model plate must be used).

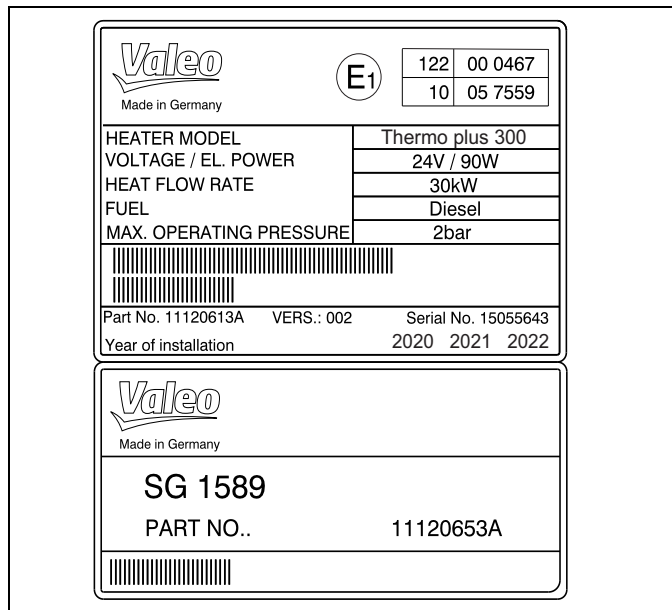

**Fig. 4: Model plate**

**NOTE:**

The year of the initial operation must be durably marked by removing the year numbers that are not applicable.

4 Installation example

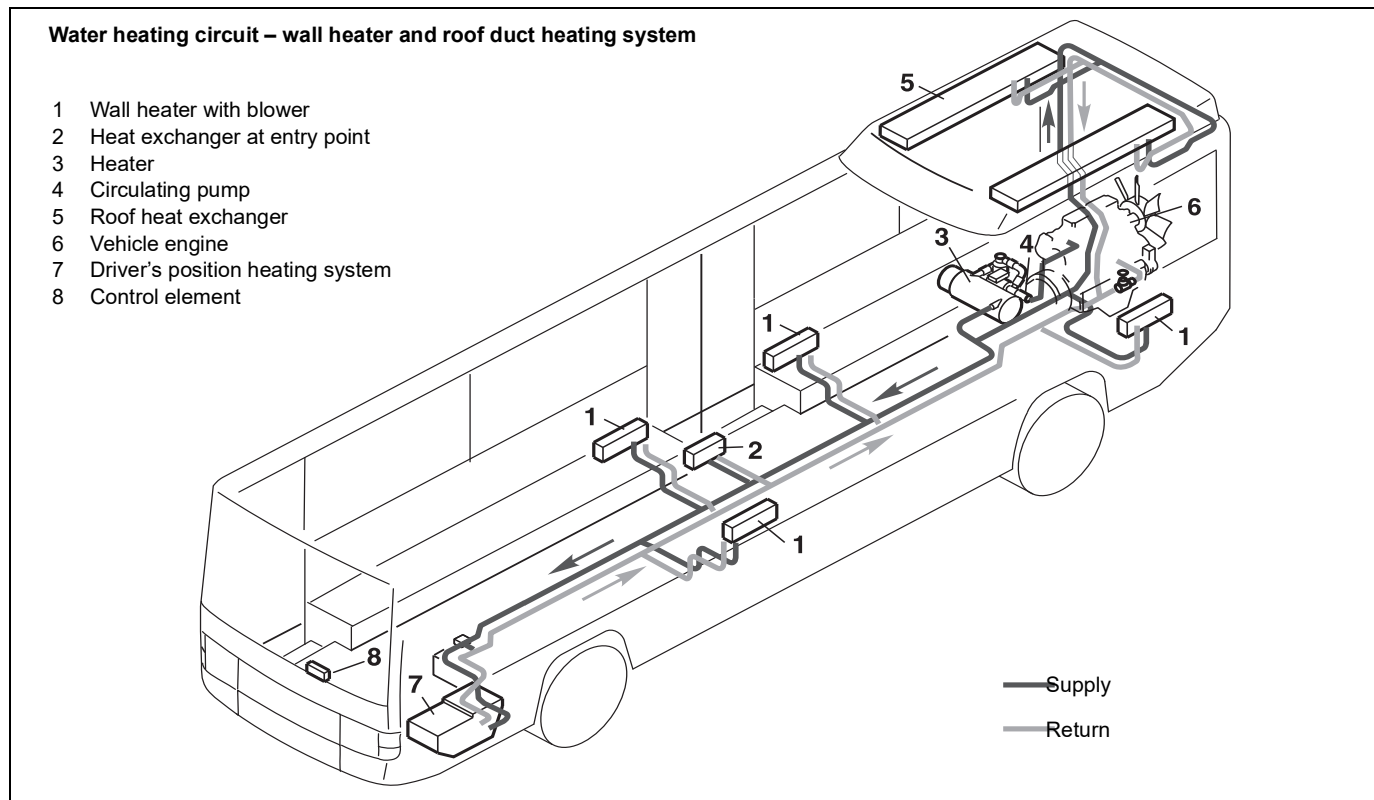

Fig. 5: Installation example for the heater

## 5 Installation of the circulating pump

### ATTENTION:

**The heater should be equipped with a Valeo circulating pump.  
Pumps of other manufacturers must be approved by Valeo.**

The following pumps are available:

- U4814 (Aquavent 5000)
- U4854 (Aquavent 5000S)
- U4855 (Aquavent 6000C)
- U4856 (Aquavent 6000SC)
- SPump



Information about these pumps and their installation you find under [http://www.valeo-thermalbus.com/eu\\_en/Products/Pumps](http://www.valeo-thermalbus.com/eu_en/Products/Pumps)

### NOTE:

- The annex of this Installation instructions contain the permitted installation positions of the pumps.
- The pump ports and connection lines from the water intake and water outlet must be flush (no stress).

### ATTENTION:

**When connecting the circulating pump U4856 it must be ensured that the volume flow does not drop below 2500 l/h for longer than a brief period only! Continuous operation at less than 2500 l/h will result in an undue wear of the wearing disc of the impeller!**

## 6 Connection to the vehicle cooling system

The heater is to be connected to the vehicle cooling system in accordance with Figures 1 and 5. The system must contain at least 25 litres of coolant. A minimum of 30% of a good quality antifreeze should be maintained in the heating circuit of the heater at all times.

A current list of approved by Valeo antifreeze agents can be found on the Valeo website.

Basically the water hoses supplied by Valeo should be used. If this is not the case, the hoses must comply at least with DIN 73411 requirements. The hoses are to be routed without any kinks and - for proper venting of the heater - in an upward pitch, if possible. Hose connections must be secured against slipping off by means of hose clamps.

### NOTE:

The tightening torques of the hose clamps used must be observed. After 2 hrs. / 100 km, the hose clamps should be retightened.

In the vehicle cooling system, or in a separate heating circuit, only pressure control valves with an opening pressure of min. 0.4 bar and max. 2.0 bar may be used.

Before the heater is started up for the first time, or after the coolant has been replaced, it must be ensured that the cooling system is properly bled. Heater and piping should be installed in such a way that static bleeding of the system is ensured.

Proper bleeding action can be recognised by the nearly silent operation of the circulating pump. Insufficient bleeding during heater operation can result to tripping of the temperature limiter.

If the circulating pump U 4855 / Aquavent 6000C is used it will be automatically deactivated approx. 10 seconds after its activation if coolant is lacking or a blockage of the pump impeller has occurred, and can then

be restarted after approx. 2 minutes.

If the circulating pump U 4856 / Aquavent 6000SC is used, it will be automatically deactivated approx. 45 minutes after its activation if coolant is lacking or a blockage of the pump impeller has occurred, and can then be restarted after approx. 2 minutes.

### ATTENTION:

**Before commissioning the heating system, the heating hoses, the pump and the heater must be completely filled.**

**Only by Valeo approved antifreeze agents may be used.**

## 7 Fuel supply

Fuel is extracted from the vehicle's fuel tank or from a separate fuel tank. Fuel lines and filters must be completely vented without using the fuel pump of the heater before commissioning. Thereby also during vehicle operation a safe fuel supply without air bubbles must be ensured continuously.

### 7.1. Fuel lines

When using fuel hoses, basically the hoses supplied or offered by Valeo are to be used. If this is not the case, the fuel hoses must at least comply with the requirements of DIN 73379. Fuel hoses must not be kinked, crushed or twisted and must be secured at intervals of about 25 cm with clamps.

Materials commonly used in the construction of vehicles may be also used for fuel hoses taking into account a suitable connection system in each case. The selection should be done considering the ambient temperature range and the fuel (Bio Diesel) used.

To prevent air inclusions from forming in the fuel, the fuel lines should be routed in an upward pitch, if possible. Connections within the fuel lines must be secured by means of hose clamps unless mechanical screwed connections are used.

To prevent the fuel lines from draining, the outlet of the return line in the tank should be below the fuel level.

#### ATTENTION:

**If the heater is operated without coolant, the outer shell of the heater may reach a temperature equalling the ignition temperature of diesel fuel!**

- The lines must be protected from thrown-up gravel
- any dripping or evaporating fuel must neither collect nor be ig-

**nited by hot components or electrical equipment.**

**To prevent this, optionally a drip pan with defined drain holes is to be installed in the area below the interface burner housing/fuel line connectors/heat exchanger.**

#### ATTENTION:

**The operation with a closed return line will cause damage to the fuel pump or fuel line. Fuel can leak out - fire hazard!**

**Fuel lines and filters must be protected against excessive heat.**

**The fuel pump must not run dry.**

**Unsupported fuel lines must be secured to prevent them from sagging.**

**The installation of an additional fuel pump is permissible only in consultation with Valeo.**

**For legal provisions refer to Chapter 1.**



### 7.1.1. Permissible dimensions of the fuel lines

- Inside diameter for suction and return lines: 6 mm (other diameters on request)
- Max. permissible length of each suction and return line: 15 m
- Max. permissible suction height: 2 m
- Max. permissible admission pressure: 0.3 bar

Deviations are to be approved by Valeo.

### 7.2. Fuel Filter

A fuel filter supplied or approved by Valeo must be used (consider the flow direction). To avoid malfunctions the filter or filter insert is to be replaced annually before the cold weather season starts.

If temperature limits of fuels have been reached, heated fuel filters are to be used. However, it is recommended to use them beforehand.

### 7.3. Operability of the heater depending on the negative pressure in the fuel system

The preferred range designed for the fuel supply system goes up to max. 350 mbar (at the heater).

For different fuel-side applications a separate approval by Valeo is required.

#### ATTENTION:

**With increasing service life, the flow resistance in the fuel supply may be increased due to deposits (e.g. the filter clogs) and the heater is more susceptible for malfunctions.**

## 8 Combustion air supply

Under no circumstances may the combustion air be taken from areas occupied by people. The combustion air intake opening **must not** point in the direction of travel. It must be located so that it cannot become clogged with dirt or snow and cannot suck in splashing water.

Permissible dimensions of combustion air intake line:

- Inside diameter: 55 mm
  - Max. permissible line length: 5 m without exhaust extension
  - Max. permissible bends: 270°
  - Total length of air intake line and exhaust pipe max. 5 m
- The combustion air intake must not be routed above the exhaust outlet.

Deviations must be approved by Valeo.

### NOTE:

If the combustion air intake line cannot be installed so that it slopes downwards, a water drain hole with a diameter of 4 mm is to be made at its lowest point.

Only by Valeo approved combustion air intake lines may be used.

When the heater is installed in the vicinity of the vehicle tank in a common installation space, combustion air must be drawn in from the outside of the vehicle and the exhaust gas be discharged into the atmosphere. Lead-through openings must be splash-proof.

If the heater is located in an enclosed installation housing, an effective ventilation opening is required with a cross-section of at least:

Thermo plus 160 / 230 / 300	30 cm <sup>2</sup>
Thermo plus 350	40 cm <sup>2</sup>

Verify by checking the CO<sub>2</sub> values whether the ventilation is effective and sufficient.

If the temperature in the installation housing exceeds the permissible ambient temperature of the heater (see Technical Data), the ventilation opening must be enlarged subject to prior consultation with Valeo.

## 9 Exhaust pipe

The opening of the exhaust pipe must be aligned against the direction of travel and must not become clogged with dirt or snow.

The outflowing exhaust gas must not be re-sucked in as combustion air. The exhaust gas must be routed to the outside / into the atmosphere.

The exhaust pipe must be fixed at least once every 50 cm.

Rigid pipes made of unalloyed or alloyed steel with a minimum wall thickness of 1.0 mm, or flexible tubes of alloyed steel are to be used.

The exhaust pipe is to be secured to the heater, e.g. by means of a clamp.

Accumulations of condensate must be drained, if necessary, a condensation water drain hole  $\varnothing$  4mm must be implemented.

Combustion air intake and exhaust gas outlet must be arranged to ensure that no air pressure difference (e.g. suction) will occur in any vehicle operating condition.

For further requirements see statutory regulations.

Permissible dimensions of the exhaust pipe:

- Internal diameter: 70 mm
- Max. permissible pipe length:  
5 m without the combustion air intake extension
- Max. permissible bend: 270°
- The total length of both, the air intake pipe and the exhaust pipe must not exceed 5 m

Deviations only after approval by Valeo.

### NOTE:

If there is a risk of contact with the exhaust pipe during intended use, it must be secured accordingly to prevent such a contact.

If the exhaust line is installed near heat-sensitive parts, it must be insulated.

### ATTENTION:

- The exhaust gas temperature can reach over 400°C depending on the heating capacity class.
- The exhaust pipe must end in the open air.
- The exhaust pipe must be sloped down, arising condensate must be able to drain away.
- Because of the temperatures involved, sufficient distance from heat-sensitive or flammable materials must be ensured.
- Outflowing exhaust gas must not be re-sucked in as combustion air.
- The opening of the exhaust pipe must be aligned against the direction of travel and must not become clogged with dirt or snow.
- If the exhaust outlet is under the vehicle floor, blowing straight down, an exhaust gas deflection is absolutely necessary.

## 10 Electrical connections

### 10.1. Heater hook-up



**Disconnect first the electrical connection to the vehicle and then to the temperature sensor prior to opening the heater. This may only be done when the heater is switched off and after the purge cycle has finished.**

The hook-up of the heaters is to be performed acc. to the system wiring diagram shown in Figure 6 or Figure 7. Failure to comply may lead to malfunctions and premature failure of the control unit.

Any plug designs that differ from the standard versions are to be requested separately from Valeo.

Before heater installation the **ripple voltage level** at the interface to the heater shall be checked. It must not be higher than 2 V<sub>ss</sub> (V<sub>ss</sub> - peak to peak). Otherwise a reduced service life of the electric and electronic components must be expected.

#### **ATTENTION:**

**The indicated wire cross sections are to be observed.**

**The negative and positive poles of the heater control unit must be connected directly to the battery.**

**Route the electrical cables so their insulation will not be damaged (i.e. wedging, temperature exposure, kinks, chafing).**

**Unused connectors must be protected by dummy plugs / caps.**

#### **NOTE:**

##### **Load dump protection**

The heater may be used for full load dump protection only in vehicles

with a central voltage limiter.

### 10.2. Connecting the controls

The heater can be switched on and off using the following Valeo controls:

- Switch, see system wiring diagram Figure 7
- Timer, see system wiring diagram Figure 6

### 10.3. Control module

The control module is installed in the heater.

### 10.4. Economy mode

The hook-up of the economy mode switch is shown in the system wiring diagram, Figures 6 and 7.

The terminal „Economy“ allows to lower the switching thresholds in the parking heat operation mode. Depending on switch position there is either:

- no signal in normal heating operation mode, or
- an operating voltage of +20.5...30V in economy mode

This makes possible in the parking heat operation mode to change between 2 operating modes with its own upper and lower temperature threshold each.

### 10.5. Terminal 61

The connection of the switch is shown in the system wiring diagram, Figures 6 and 7.

This signal input serves for changing the switching thresholds. See table in 10.6.

## 10.6. Water temperature control thresholds (standard values):

Heater	Aux. heating (Terminal 61)		Parking heating		Econ. setting	
	On	Off (CI)	On	Off (CI)	On	Off (CI)
<b>Thermo plus 160</b> <b>Thermo plus 230</b> <b>Thermo plus 300</b> <b>Thermo plus 350</b>	72	82	67	77	55	70

CI: control idle

On/Off: lower / upper threshold

Auxiliary heating: Heater is operating, engine is operating

Parking heating: Heater is operating, engine is off

Economy setting: Control temperature is on a lower level

### NOTE:

Auxiliary heating has priority over the economy setting!

For further information on the operating modes economy setting, auxiliary heating and parking heating, refer to the Workshop Manual.

## 10.7. Wiring diagrams

### 10.7.1. Legend for wiring diagrams:

Position	Designation
BA	Operation indicator 3W (max. 5W)
FA	Flame indicator 3W (max. 5W)
UP	Circulation pump
STT	Spheros Thermo Test (diagnostic tool)
F1, F2*	Car flat-type fuse 25A acc. to DIN 72581 part 3 or ISO 8820-3
F3 - F7	Car flat-type fuse 5A acc. to DIN 72581 part 3 or ISO 8820-3
HS	Main switch
UPFA	Circulating pump external control
Spar	Economic setting
DVW	Nozzle preheater (in the heater)
ZFG	Electronic ignition unit (in the heater)
MV	Solenoid valve (in the heater)
BM	Combustion air motor (in the heater)

Legend for wiring diagrams

\* Note for F2: The max. possible for the design value is shown. The fuse is to be adapt under circumstances acc. to the smaller cable cross section of the connected circulating pump.

#### NOTE:

The vehicle fuses must be installed in such a way that their ambient temperature does not exceed 60 °C.

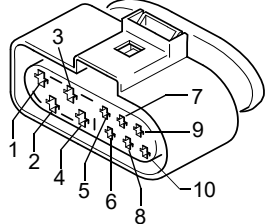
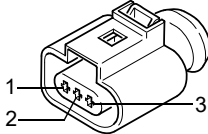
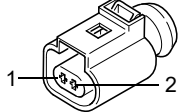
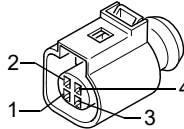
Connector	Description	
<b>C</b>	<b>To vehicle (Power)</b>	
C1	Terminal 30 (+), UP (DVW)	
C2	Terminal 31 (-), UP (DVW)	
C3	Terminal 30 (+), HG	
C4	Terminal 31 (-), HG	
C5	Main switch	
C6	UPFA	
C7	Terminal 61 (D+)	
C8	Economic setting (Spar)	
C9	Operation indicator +	
C10	Flame indicator +	
<b>T</b>	<b>Temperature sensors</b>	
T1	Temp. sensor PT2000 +	
T2	Overheat protection PT500 +	
T3	Ground	
<b>P</b>	<b>Circulating pump</b>	
P1	Circulating pump +	
P2	Circulating pump -	
<b>G</b>	<b>Diagnosis STT</b>	
G1	Terminal 30	
G2	Ground	
G3	S Bus	
G4	--	

Connector pin assignment

**10.7.2. Connectors**

If a circulating pump is connected to the heater, a Valeo cable harness is to be used.

The crimping for the connectors must be carried out according to the manufacturer's instructions. If no STT diagnosis or recirculation pump is connected, the not used connectors must be closed by the associated blind plug.

Only the following mating connectors may be used:

General note: Single-wire seals must be carefully selected, properly and tightly processed.

**Connector "P" (circulating pump)**

Housing FEP 4212 1100

A cable cross-section of 2.5mm<sup>2</sup> is recommended. From a nominal current of 7A, the cable cross-section must be 2.5mm<sup>2</sup>.

Contact: Tyco 964273-1 (CuFe/ tin-plated) for cable cross-section

1.5 ... 2.5mm<sup>2</sup> with single-wire seal: cable cross-section 2.5mm<sup>2</sup> Tyco 963292-1 yellow (insulation diameter 2.7 ... 3.0mm)

→ Connector package Valeo ID: 11114939\_ or blind plug: Valeo ID: 11113969\_

**Connector "C" (customer connector)**

Housing FEP 4212 3300

1.5mm contact: Tyco 964274-2 (CuFe/ tin-plated) for cable cross-section 0.75mm<sup>2</sup> with single-wire seal: Tyco 963530-1

Not used connections must be closed with a blind plug: Tyco 963531-1 (white)

2.8mm contact: All 4 terminals must be used with a cross-section of 2.5mm<sup>2</sup>. Tyco 964273-1 (CuFe/ tin-plated) for cable cross-section

2.5mm<sup>2</sup> with single-wire seal: Tyco 963292-1

→ Connector package Valeo ID: 11120719\_

**Connector "G" (STT Diagnosis)**

To connect the Spheros Thermo Test diagnosis or the blind plug:

→ Blind plug Valeo ID: 11119375\_

**Plug-in cycles**

We refer to the max. number of 10 plug-in cycles. After exceeding or obvious shortages, the affected contacts have to be renewed.

**10.7.3. Cable cross-sections****ATTENTION:**

**For vehicle cable lengths up to 7.5 m, at least the prescribed cable cross-sections shall be used. For vehicle lengths of 7.5 m to 15 m, the cable cross-sections in the vehicle must be designed larger. At least the cable cross-sections given in the table must be used. Please note that the cable cross-section at the heater must not exceed 2.5mm<sup>2</sup>. In the case of larger cable lengths, a cross-section reduction must be carried out before the heater. The generally valid electrotechnical rules apply.**

Indicated cable cross-section	Vehicle cable length	
	<7.5m	7.5 - 15m
0.75mm <sup>2</sup>	0.75mm <sup>2</sup>	1.5mm <sup>2</sup>
2.5mm <sup>2</sup>	2.5mm <sup>2</sup>	4.0mm <sup>2</sup>

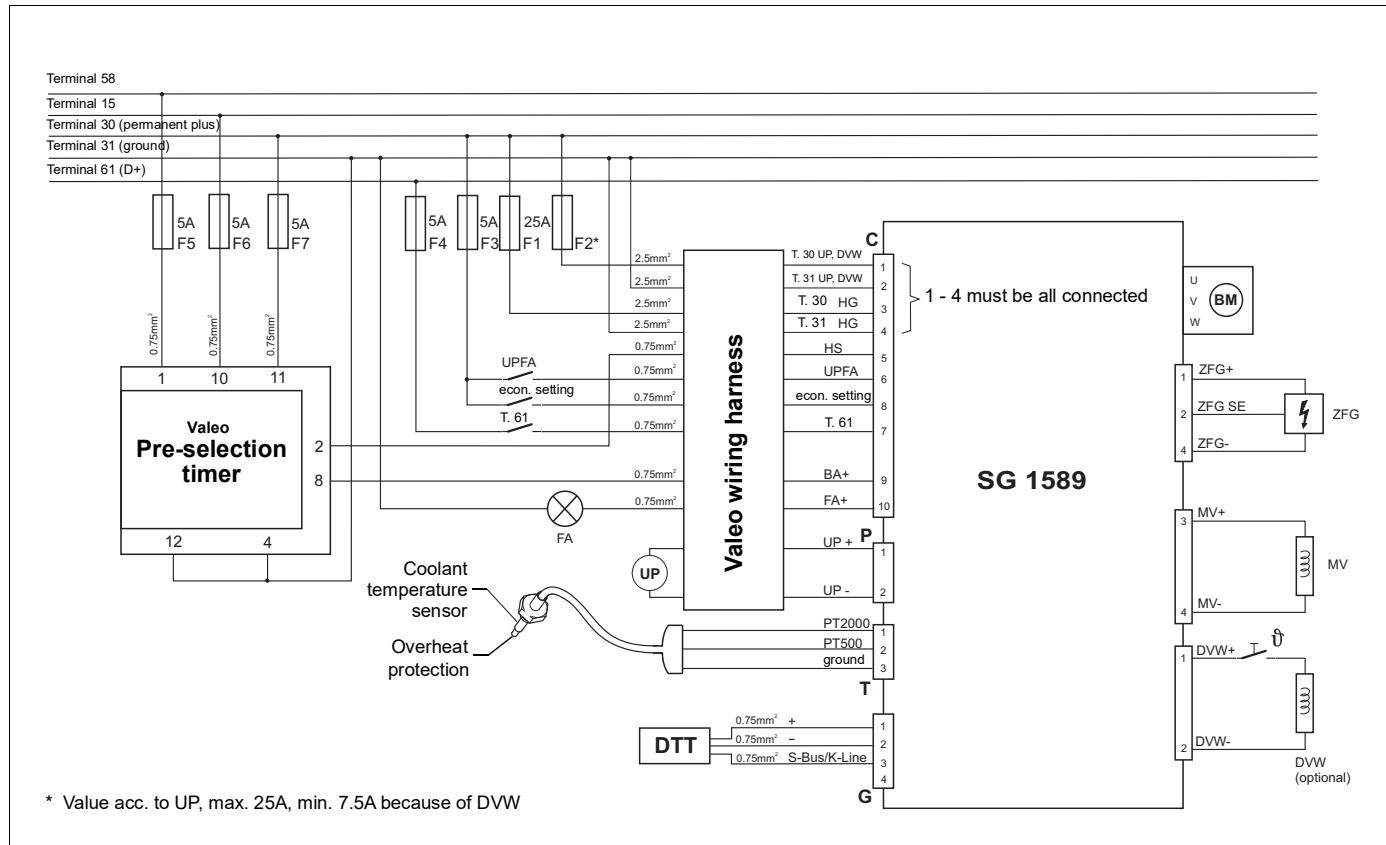

Fig. 6: System wiring diagram for the heater Thermo plus with pre-selection timer, legend see page 47



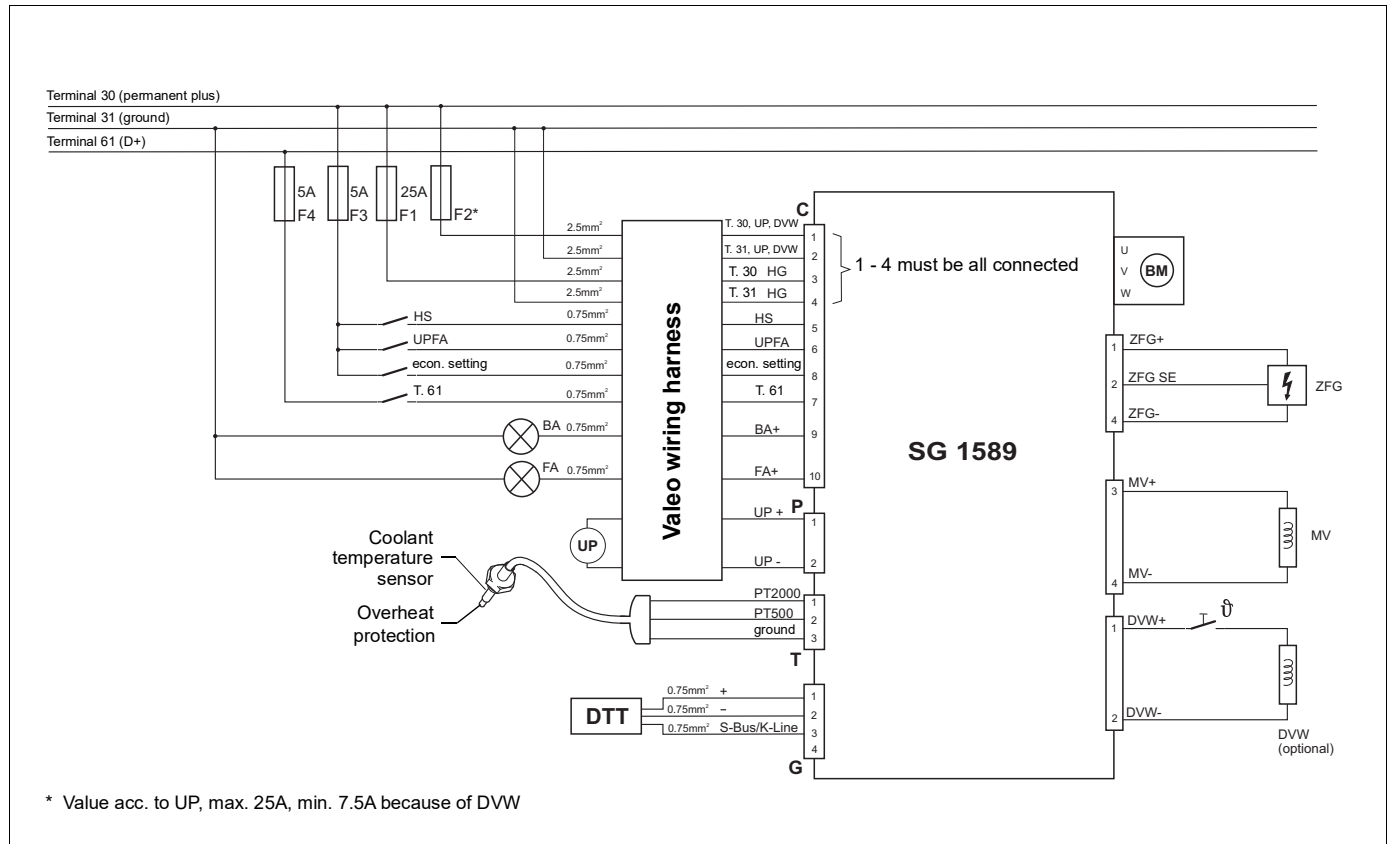

Fig. 7: System wiring diagram for the heater Thermo plus with switch, legend see page 47

## 11 Initial start-up

### NOTE:

It is mandatory to read through the Operating and maintenance instructions as well as the Installation instructions before starting the heater.

The safety precautions given in the above mentioned documents must be strictly adhered to!

The heaters are adjusted in the factory and can be used unlimited without a change of the CO<sub>2</sub> adjustment up to an altitude of 1500 m above MSL and up to 2000 m above MSL if that is a short stay in such conditions (pass crossing, break).

In case of a permanent heater operation above 1500 m the CO<sub>2</sub> setting must be readjusted, due to a negative change of the exhaust gas values in result of the decreased air density.

It is also recommended to adjust the CO<sub>2</sub> content according to the technical data if combustion air supply or exhaust gas applications are used.

After heater installation, bleed the water system and the fuel supply system carefully. In this process it is mandatory to fill the suction line and the fuel filter of the heater completely. Valeo recommends the usage of a separate bleeding unit. Follow the appropriate instructions provided by the vehicle manufacturer. Verify the fuel supplied to the heater is bubble-free.

### ATTENTION:

**The fuel pump must not be used to fill / bleed the fuel system!**

Generally, the hook-up of the heater to the vehicle power grid must be done only after filling / bleeding the fuel system in order to prevent a premature start of the fan motor/fuel pump.

Conduct a test run of the heater to check all the water and fuel connections for leaks and to ensure that they are secure. If the heater suffers a fault during operation, the fault must be located and remedied according

to given in the workshop manual instructions.

### ATTENTION:

**In the event no fuel comes to the fuel pump during initial start-up (dry running), there is a risk that the fuel pump will be damaged!**

## 12 Maintenance

Periodic service activities have to be performed in accordance with the Workshop Manual.

## 13 Malfunctions

During all active operating phases of the heater, all electric components, the operating voltage and functional irregularities are monitored and recorded.

If there are any faults, proceed as follows:

Switch off the heater and then switch it on again. If the heater doesn't start, check the following:

- Is the fuel supply ok?
- Is a sufficient amount of fuel in the tank?
- Are the fuses ok?
- Are the electrical connections and cables in order?
- Are the combustion- and exhaust air ways free of obstructions?

A malfunction causes the heater to terminate its operation by a fault shut-off and to go into the fault lock-out mode to prevent the heater from an automatic combustion restart. At the same time the operation indicator begins to flash with a specific code (see 13.1).

The fault lock-out occurs:

- low voltage during a defined period
- if combustion was not established during start-up
- if the flame extinguishes during operation
- extrinsic light
- if the control device itself has failed or peripheral components are defective

Variants to reset the heater after a fault lock-out:

1. Switch off the heater and then turn it on again
2. Reset the control device, e.g. through disconnecting it from the

power supply

3. „Off“ and „On“ switching“ via the S-Bus diagnostic interface
4. Erase the data in the fault memory by means of the diagnostic tool.

Additional to the fault lock-out a heater lock-out occurs if safety related components are affected. The fault code 12 will be displayed (see 13.1).

If a heater lock-out has occurred, the heater must be maintained and released by Valeo trained personnel.

### 13.1. Flash code

The kind of malfunction is indicated by the operating indication light through a flash code or if the timer is used in the display (operation display). The flash code is immediately generated after detection of the malfunction and will be kept until the heater is freed.

The flash code comprises of a burst (sequence) of 5 short flashes depicting the break and a defined number of long pulses corresponding to the malfunction number, which are to be counted. After that the cycle starts with 5 short flashes again and so on.

The meaning of the number of long pulses is shown in the table below.

Table: Flash code

No. of long pulses	Description of malfunction
0	not used
1	No start within the safety time
2	Flame interruption, restart failed
3	Low voltage / overvoltage
4	Extrinsic light before starting or within the purge cycle
5	not used
6	Temperature sensor / overheat protection defective
7	Solenoid valve defective
8	Combustion air fan motor / control device defective
9	Circulating pump defective
10	Overheat protection has been activated
11	Electronic ignition unit defective
12	Heater fault lock-out - deactivation necessary
13	not used
14	not used
15	Revolution signal faulty

## 14 Technical data

Except where limit values are specified, these technical data refer to the usual heater tolerances of  $\pm 10\%$  at an ambient temperature of  $+20^{\circ}\text{C}$  and at the rated voltage.

### NOTE:

The assignment of circulating pumps to heaters must be made considering the water-side resistances.

### 14.1. Fuel

Suitable fuel is the diesel fuel specified by the vehicle manufacturer.

The following table lists the by Valeo approved fuels and their specifications.

Fuel	Requirements acc.	Remarks
Summer Diesel	DIN EN 590	
Winter Diesel	DIN EN 590	
Arctic Diesel and Diesel for a strong winter climate	DIN EN 590	
Bio Diesel (FAME)*	DIN EN 14214	max. 20% see TI Fuels
Paraffinic diesel fuel from synthesis or hydro-generation (HVO)*	DIN EN 15940	only selected fuels see TI Fuels

- \* Further information on approved fuels contains the TI (Technical Information) Fuels. It can be found on the Valeo homepage under Service/Technical Updates (TI)/Heating systems.



In case of air temperatures below  $0^{\circ}\text{C}$  a commercially available winter Diesel fuel, at temperatures below  $-18^{\circ}\text{C}$  a Diesel for arctic climate conditions must be used.

The usage of flow improvers respectively additives is permitted. There are no negative influences due to additives known.

### ATTENTION:

**While using the fuels, their operating limits must be considered and if necessary, suitable measures (nozzle preheating, electrical heated filter) should be applied.**

**If fuel is supplied from the vehicle tank, follow the vehicle manufacturer's instructions on additives.**

Heater		Thermo plus 160	Thermo plus 230	Thermo plus 300	Thermo plus 350
ECE Type Approval Number	E1 122R 00	0580	0466	0467	0468
Kind of construction		High pressure atomizer			
Heating flow (at ambient temperature of 20°C)	kW (kcal/h)	16 (13 800)	23 (20 000)	30 (26 000)	35 (30 000)
Fuel		Diesel / Heating oil			
Fuel consumption	kg/h	1.6	2.5	3.0	3.6
Rated voltage	V =	24			
Operating voltage range	V =	20.5 ... 30			
Rated power consumption at 24V *	W	65	60	90	120
Max. permitted temperature of sucked combustion air	°C	+ 85			
Permitted ambient temperature during operation	°C	-40...+ 100			
Permitted storage temperature	°C	-40...+ 110			
Permitted operating overpressure	bar	max. 2.0			
Capacity of the heat exchanger	l	1.8			
Minimum water flow **	l/h	1400	1900	2400	2700
Minimum capacity of the water system	l	25			
CO <sub>2</sub> in exhaust gas at rated voltage	Vol %	9.5 + 1.0	9.0 + 1.5	9.5 + 1.5	9.5 + 1.5
Heater dimensions (tolerance ± 3 mm)	mm	Length 540 / Width 250 / Height 222			
Weight	kg	16.5	16.8		

\* without circulating pump

\*\* Minimum water flow at coolant temperatures above 50°C

Below 50°C a lower water flow is permitted, if the occurrence of vapor bubbles due to local overheating safely can be excluded.

Circulating pump		U 4814 Aquavent 5000	U 4854 Aquavent 5000S	U 4855 Aquavent 6000C	U4856 Aquavent 6000SC	SPump 260
Delivery rate	l/h	5000 (against 0.2 bar)	5000 (against 0.2 bar)	6000 (against 0.4 bar)	6000 (against 0.4 bar)	6000 (against 0.5 bar)
Rated voltage	V =	12 or 24	24	24	24	24
Operating voltage range	V =	10...14 / 20...28	20...28	20...28	20...28	16.5...32
Rated power consumption	W	104	104	210	210	260

**Note:** For further technical data e.g. dimensions, refer to the pumps documentation.

**Optional Fuel Filter Heater**

Filter heater		
Rated power consumption	W	240
Rated voltage	V -	24
Switch-on point	C°	0.5 ± 2.5
Switch-off point	C°	5.5 ± 2.5



## 15 Environment

### Recycling of heater parts

The correct disposal of the heater components determined by material groups for old appliances, damaged or defective parts and packaging material can be realized without problems. In the process the materials as steel, non-ferrous metals, plastics and electrical scrap (as motors, control devices, harnesses and sensors) are to be professionally and environmentally friendly disposed by the recycling plant.

The heater disassembly is precisely described in the workshop manual. For the package the same recycling conditions applies as for paper and paperboard. Keep the package a defined period for a possible return shipment.

## Annex

## Circulating pumps installation position

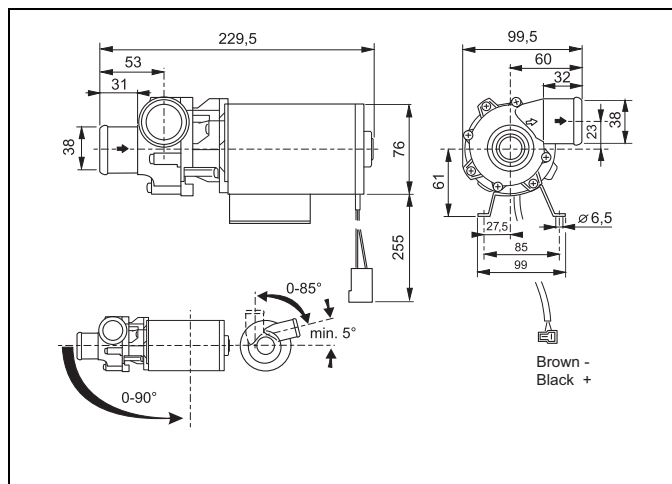

U 4814 Installation position

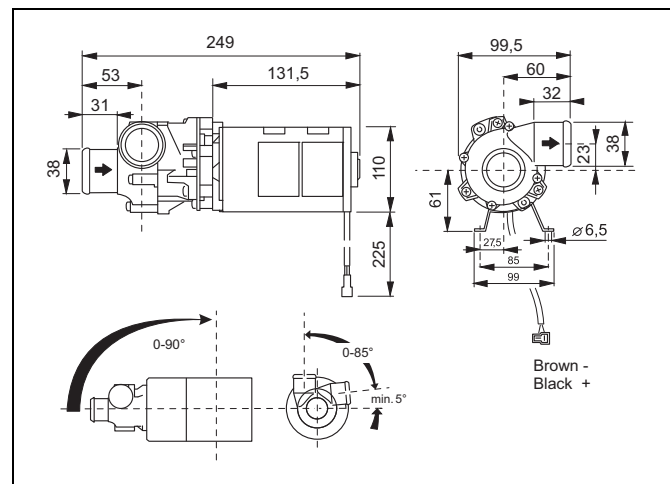

U 4854 Installation position

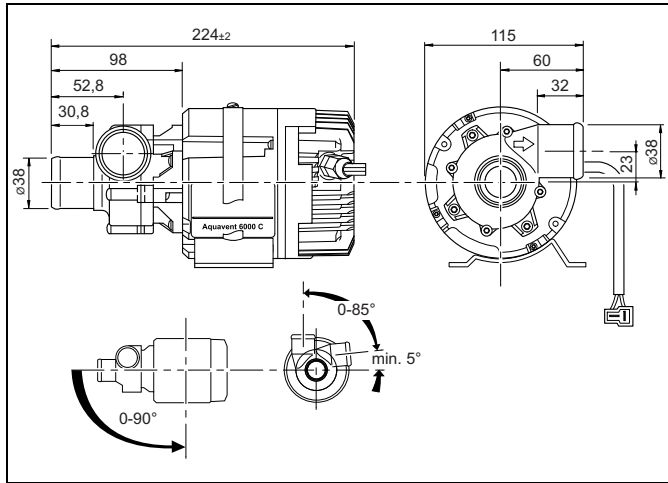

**U 4855 Installation position**

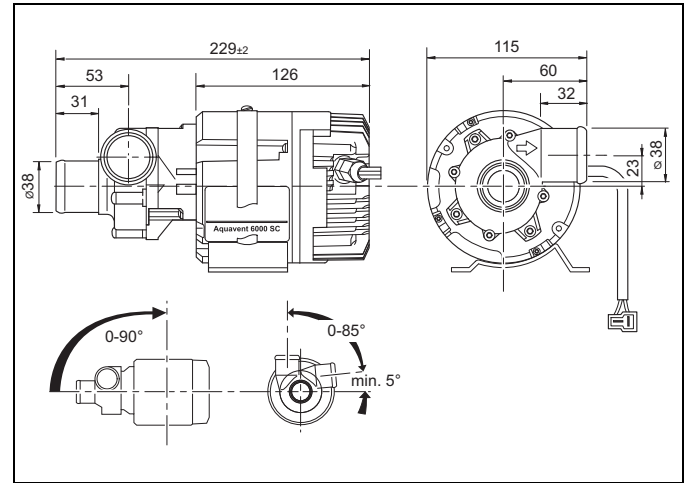

**U 4856 Installation position**

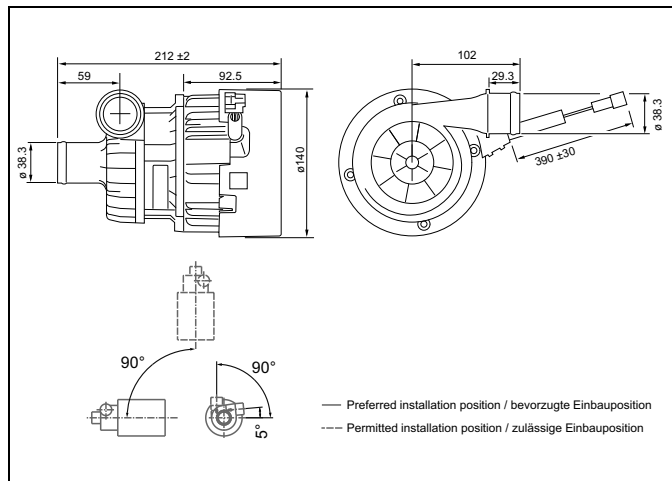

SPump Installation position

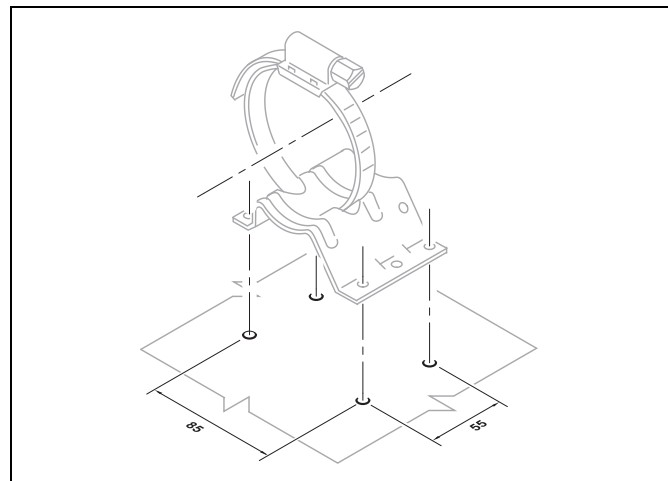

Hole pattern for stand

memos

---



---



---



---



---



---



---



---



---



---



---



---

Valeo Thermal Commercial Vehicles Germany GmbH  
Friedrichshafener Str. 7 - 82205 Gilching - Germany - Tel. +49 8105 7721-0 - Fax +49 8105 7721-889  
[www.valeo-thermalbus.com](http://www.valeo-thermalbus.com) - [service-valeobus@valeo.com](mailto:service-valeobus@valeo.com)