

SPLIT SYSTEMS FOR SHUTTLE AND SCHOOL BUSES

# TROPICCOOL

25065 SKIRT MOUNTED CONDENSER



## PERFORMANCE, RELIABILITY & LOOKS

Valeo provides the best performance and reliability for the application your vehicle requires by manufacturing several different condenser designs. Certain applications provide a more aesthetic OEM look to the bus by eliminating the need to cut intakes in the skirt of the bus.

[BEST-BUS-CLIMATE.COM/US](http://BEST-BUS-CLIMATE.COM/US)



# 25065 SKIRT MOUNTED CONDENSER

## HIGHLIGHTS



### Design

- Designed to be skirt mounted
- High performance motors with extended brush life
- Fabricated from galvanized steel & covered in corrosion resistant epoxy for durability
- Inlet filter on condenser protects coil from contaminants



### Environmental Friendliness

- High performance parallel flow condenser
- Highly efficient all aluminum micro channel coil



### Features

- Two 14" diameter high performance fans covering a larger percentage of surface area on condenser coil

- Easy Installation without having to cut intakes in skirt of bus-school bus

### Key Components

- Coil:
- Fan:
- Filter:

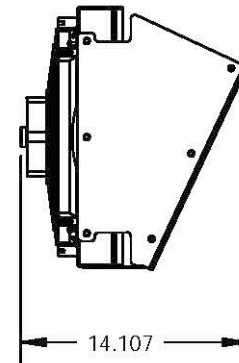
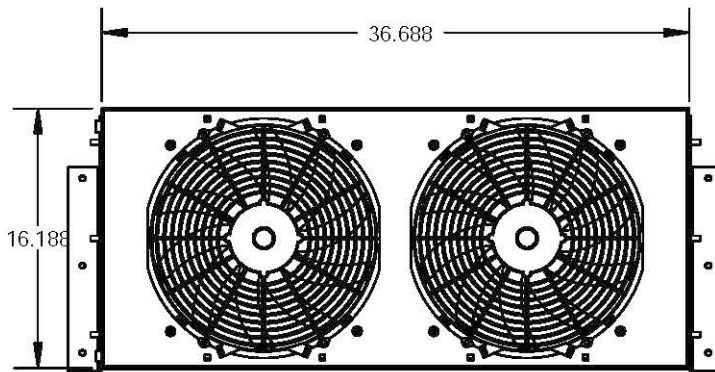

## TECHNICAL DATA

Model	Up to Cooling Capacity	Power Consumption	Nominal Voltage	Dimensions W x H x D	Weight
25065	83,000 BTU/h	22 Amps	12V	37 x 3 x 16 in	51 lbs.



Valeo Thermal Commercial Vehicles North America, Inc. - 22150 Challenger Drive Elkhart, IN 46514  
 Phone 574-264-2190 - Toll free 800-462-6322 - Fax 574-326-3015  
[www.valeo-thermalbus.com/us](http://www.valeo-thermalbus.com/us) - [tcv.na-sales.mailbox@valeo.com](mailto:tcv.na-sales.mailbox@valeo.com)

Valeo Thermal Commercial Vehicles (TCV), formerly known as ACC Climate Control/Spheros North America.