

PREMIUM BUS HEATER

THERMO E+

120 / 200 / 320



STATE-OF-THE-ART FOR A WIDE APPLICATION RANGE

In addition to its low weight, the Thermo E+ series is a real winner in terms of consumption. And it was almost a foregone conclusion that our heaters would work efficiently even at temperatures as low as -40 °C.

They are available in 12V or 24V and also with a single or dual fuel line system. The 12 kW version was conceived as an auxiliary heater for mini, midi and e-buses. Incidentally, it is one of the shortest, and at 13.5 kg one of the lightest heaters in its class.

BEST-BUS-CLIMATE.COM



HIGHLIGHTS



Low life-cycle costs

- Simple maintenance via Diagnosis Thermo Test (DTT)
- Further savings in fuel consumption due to low heater weight



Reliability & durability

- Powerful even in cold areas up to -40°C
- High safety standards due to temperature sensors and self protection function



Environmentally friendly

- Low fuel consumption due to high efficiency
- Suitable for alternative fuels according to DIN EN 15940
- Fuel savings due to external control of the circulation pump
- Emission values significantly below current standards
- Noise emission optimized



Extended application range

- Wide range of applications
 - Due to 12 kW version even in mini,- and midi buses
 - as an additional heater in E-buses
- Available in 12V or 24V
- External circulating pump actuation
- As single or dual fuel line system
- Thermo E+ 120 is one of the shortest heaters in its class

Installation dimensions for Thermo E+

Thermo E+ 200 / 320

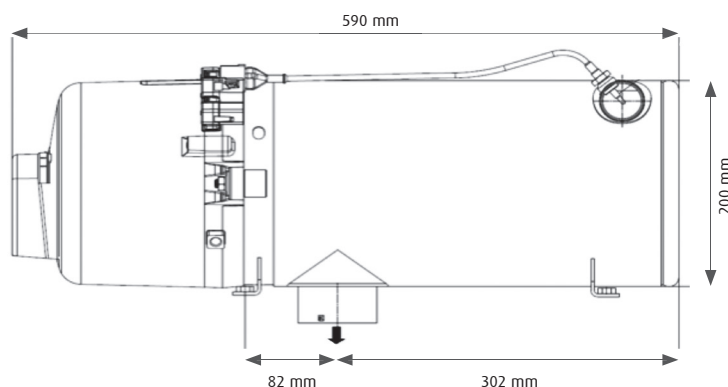

Thermo E+ 120

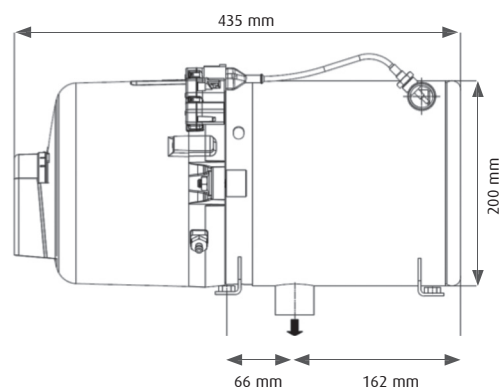

TECHNICAL DATA

| | Thermo E+ 320 | Thermo E+ 200 | Thermo E+ 120 |
|-------------------------------------|-----------------|-----------------|-----------------|
| Heat output (kW) | 32 | 20 | 12 |
| Fuel consumption (kg / h) | 3.2 - 4.1 | 2.0 - 2.7 | 3.2 - 4.1 |
| Rated voltage (V) | 12/24 | 12/24 | 12/24 |
| Temperature range in operation (°C) | -40 to 85°C | -40 to 85°C | -40 to 85°C |
| Dimensions L x W x H (mm) | 590 x 248 x 224 | 590 x 248 x 224 | 435 x 248 x 224 |
| Weight (kg) | 17.3 | 16.5 | 13.5 |