

PREMIUM BUS HEATER

# THERMO PLUS

230 / 300 / 350



## THE SHORTER THE HEATER THE BETTER

To cut a long story short: our Spheros Thermo plus heater is the latest result from almost 40 years of development, production and sales.

It is significantly shorter and lighter than its predecessors, and has an extended service life while producing less starting noise and exhaust emissions.

Optional  
J1939

[WWW.SPHEROS.COM/US](http://WWW.SPHEROS.COM/US)

**SPHEROS**

## HIGHLIGHTS



### Low life-cycle costs

- Lower vehicle fuel consumption due to reduced heater weight
- Brushless EC motor enables extended running times
- Maintenance-friendly



### Environmentally friendly

- Lower internal consumption of the heater over a heating period
- Reduced exhaust emissions when starting
- Less starting noises



### Comfort

- Engine-independent heater operation
- 3 performance classes from 78,479 to 119,424 BTU/hr

Installation dimensions for Thermo plus

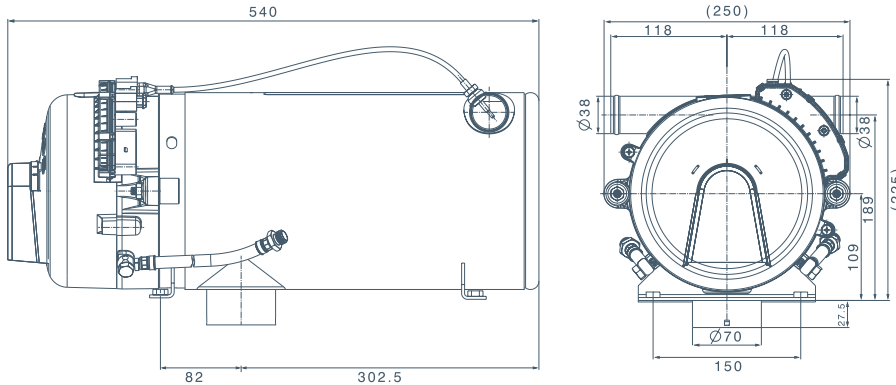

Size comparison

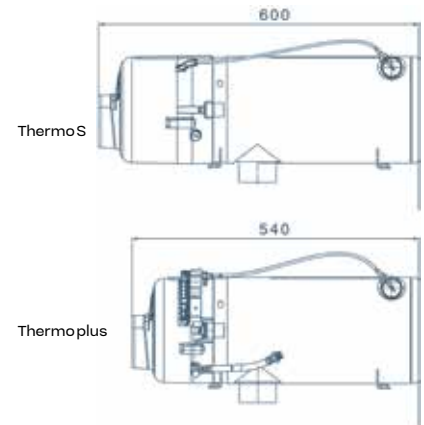

Note: The measurements in the drawing are in millimeters (mm).

## TECHNICAL DATA

	Thermo plus 230	Thermo plus 300	Thermo plus 350
Heat output (BTU/hr)	78,479	102,364	119,424
Power consumption (W)	60	90	120
Fuel consumption (l / h)	3.0	3.6	4.3
Rated voltage (V)	24	24	24
Dimensions L x W x H (in)	21.30 x 9.84 x 8.81		
Weight (lbs)	35.28	35.28	35.28
CAN Communication	Optional*		

\*Separate external gateway required. Please contact your Regional Sales Manager.