

Premium bus heater

THERMO PLUS

230 / 300 / 350



The shorter the heater the better

To cut a long story short: our Spheros Thermo plus heater is the latest result from almost 40 years of development, production and sales.

It is significantly shorter and lighter than its predecessors, and has an extended service life while producing less starting noise and exhaust emissions.

WWW.SPHEROS.COM

SPHEROS

HIGHLIGHTS



Low life-cycle costs

- Less fuel consumption due to reduced short burning times (30 % over a heating period).
- Brushless EC motor enables extended running times
- Maintenance-friendly



Environmentally friendly

- Lower internal consumption of the heater over a heating period
- Reduced exhaust emissions when starting
- Less starting noises
- Emissions are well below current standards
- Suitable for operation with alternative fuels approved by Spheros according to TI (Technical Info) and DIN EN 15940



Comfort

- Engine-independent heater operation
- 3 performance classes from 23 to 35 kW
- External control of the circulation pump

Installation dimensions for Thermo plus

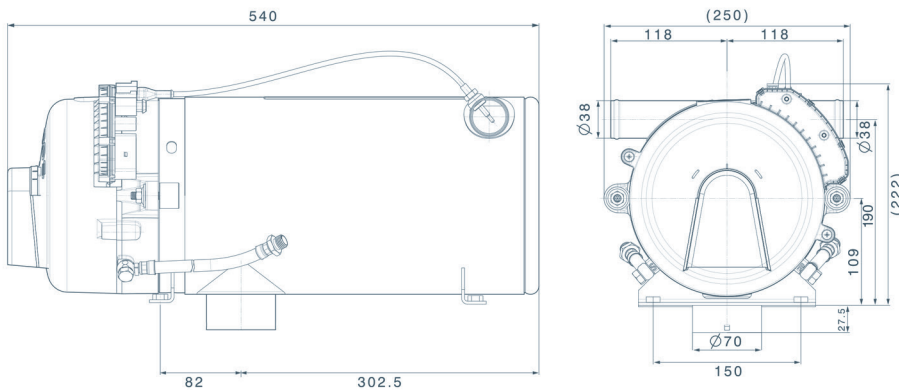

Size comparison

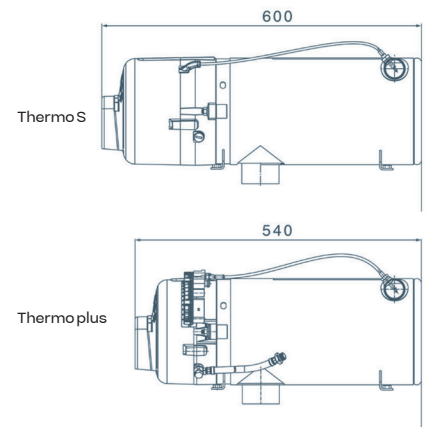

TECHNICAL DATA

	Thermo plus 230	Thermo plus 300	Thermo plus 350
Heat output (kW)	23	30	35
Power consumption (W)	60	90	120
Fuel consumption (l / h)	3.0	3.6	4.3
Rated voltage (V)	24	24	24
Dimensions L x W x H (mm)	540 x 250 x 222		
Weight (kg)	16	16	16