

FIT SERIES

CONVENTIONAL FIT



Global Safety with CO2 free ventilation

FIT series Emergency Exit Ventilator hatches are designed to meet the Global Safety standards. It will comply with the following regulations: UN ECE, FMVSS, CCAP, and ADR 44/02.

Due to lack of space on the roof, FIT hatches have been designed for transversal and lengthwise installation. Space is precious and we have the solution. The lengthwise version roof cut out is 90mm shorter than traditional hatches saving space, material and, weight.

The hatches are available with manual or electric 12/24V remote control mechanisms and with glass and plastic domes. The electric version can be operated with analog switches, with a dedicated Driver Unit, or with a CAN control. Thus the ventilation system can be fully integrated to the vehicle HVAC environment.

Conventional FIT hatches are optionally also available with an integrated extractor ventilator fan. The ventilator effectively boosts the air exchange; removes hot air, odors, and unwanted viruses.

Escape mechanisms are independent from interior trim. This makes it possible for the body builder to design their own inner trim or use the Spheros universal version.

HIGHLIGHTS



Safety

- Boosts air exchange
- Easy emergency escape release
- No glass break hammer required (optional)
- Minimizes infection risk



Comfort

- Manual or electric remote control
- Analog or digital interface
- Dedicated Driver Unit available
- CAN integration
- Optional integrated exhaust vent



Environmentally friendly

- Materials are recyclable
- Maintenance free for life
- No operation cost
- Integration to vehicle HVAC system
- Ventilation saves cooling energy

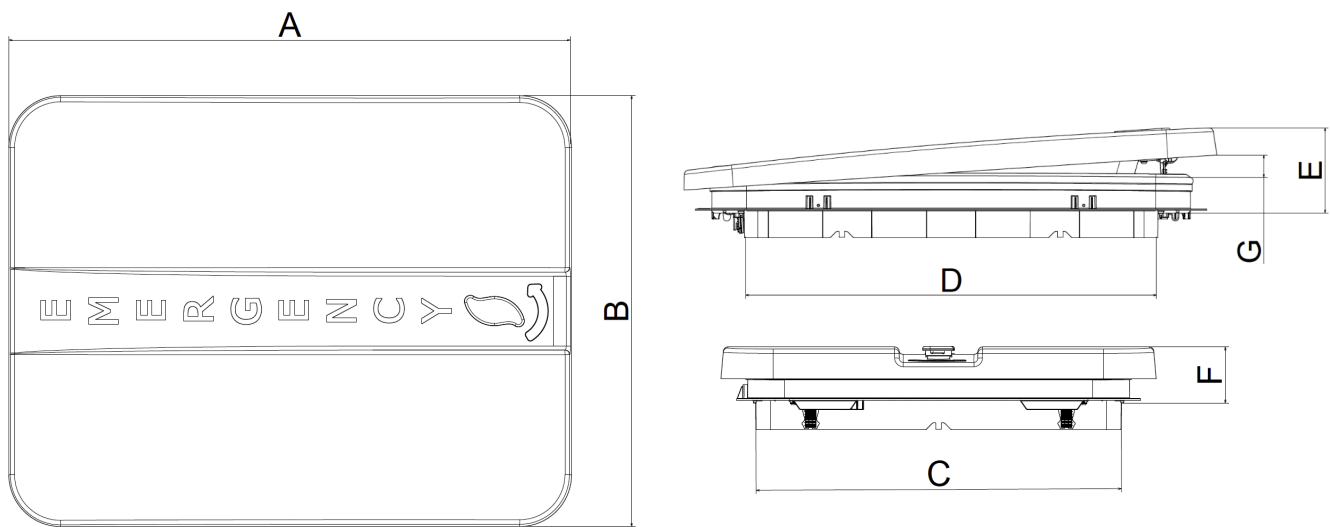

TECHNICAL DATA

FIT Series Conventional Fitting	FIT	FIT Comfort	FIT Clear	FIT Clear Comfort
Cut-off (mm)	880 x 630 ⁺³ R60	880 x 630 ⁺³ R60	880 x 630 ⁺³ R60	880 x 630 ⁺³ R60
Dome (mm)	(A) 978 x (B) 748	(A) 978 x (B) 748	(A) 910 x (B) 690	(A) 910 x (B) 690
Interior opening (mm)	(C) 615 x (D) 746	(C) 615 x (D) 746	(C) 615 x (D) 746	(C) 615 x (D) 746
Height open / closed (mm)	(E) 147 / (F) 96	(E) 147 / (F) 96	(E) 121 / (F) 70	(E) 121 / (F) 70
Ventilation opening (mm)*	(G) 48	(G) 48	(G) 48	(G) 48
Weight Hatch (kg)**	9.0	9.2	8.9	9.1
Weight inner trim (kg)**	0.5	0.5	0.5	0.5
Operation Voltage (V)	(-)	9-32 VDC	(-)	9-32 VDC
Control unit	(-)	Digital or Analog control DHC2, DU, CAN	(-)	Digital or Analog control DHC2, DU, CAN
Dome	ASA protected ABS	ASA protected ABS	4mm Safety Glass White Milk Glass	4mm Safety Glass White Milk Glass
Fuse (A)	(-)	5A	(-)	5A
Glazing Material	(-)	(-)	UN ECE R.43.01s2	UN ECE R.43.01s2
Emergency Exit Approval	R.107.08, FMVSS, CCAP, ADR 44/02	R.107.08, FMVSS, CCAP, ADR 44/02	R.107.08, CCAP, ADR 44/02	R.107.08, CCAP, ADR 44/02
Flammability approval	UN ECE R.118.03	UN ECE R.118.03	UN ECE R.118.03	UN ECE R.118.03
EMC approval	(-)	UN ECE R10.05	(-)	UN ECE R10.05