

# ELECTRIC FAN EF3/EF6



## Air exchange booster that ensures a maximum of safety.

Attractively designed electric fan with a modern look. The aerodynamic dome of the unit has been designed to create under pressure and thus static suction. Together with the inner panel, it forms a complete, stylish unit.

The EF units provide effective ventilation for all buses, coaches and minibuses and can be combined with all Valeo roof hatches to achieve maximum air exchange.

The EF6 is up to 20 % more effective in terms of airflow thanks to the new injection-moulded duct. It has an air exchange capacity of 456 m<sup>3</sup>/h. The air in an average bus (75 m<sup>3</sup>) is exchanged every 10 minutes.

## HIGHLIGHTS



### Design

- Aerodynamic
- Stylish interior trim
- Compact size
- White ASA /ABS dome as standard



### Comfort and installation

- Easy to mount / install
- Standard version with integrated inner panel unit with exchangeable filter
- Mounting up to 80 mm roof thickness due to uncut duct
- Quiet air ventilation



### Environmentally-friendly

- Waterproof
- Rustproof / stainless
- Long life motor



### Options

- Single or double speed options available
- Stepless control for usage with single speed units 1/12 and 1/24
- Available as static ventilator without axial fan
- Special MB Sprinter version obtainable on request

### Optional interior panel

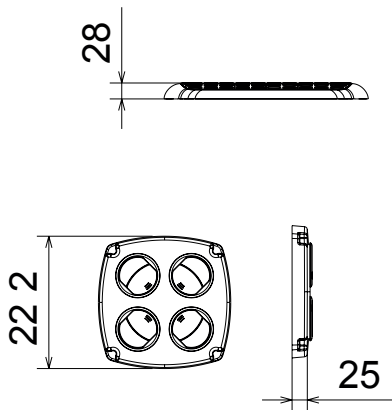

### EF3

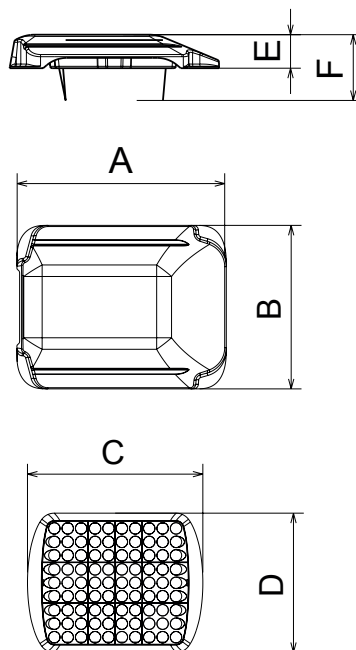

### EF6 Zeichnung dazu fehlt

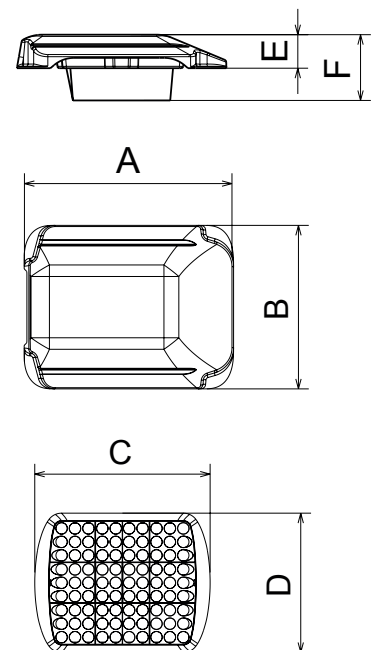

## TECHNICAL DATA

	EF3	EF6
Air flow capacity (m³/h)	375	456
∅ Assembly hole (mm)	200	235
Cut-off size (mm)	200	235
Dome Length x Width (A x B, mm)	402 x 317	485 x 350
Inner Panel Length x Width (D x C, mm)	270 x 340	170 x 340
Height above roof / in total (E/F, mm)	65 / 127	90 / 130
Operating Voltage (V)	12 / 24	12 / 24
Mass basic hatch (kg)	2.6	2.6
Power Consumption (A)	2.6 A (24V) / 4.5 A (12V)	2.6 A (24V) / 4.5 A (12V)
EMC Approval	UN ECE R10.04	UN ECE R10.04